

Up to PL e of EN ISO 13849-1 PNOZ 11



Safety relay for monitoring E-STOP pushbuttons and safety gates.

Approvals

	PNOZ 11
	◆
	◆
	◆

Unit features

- ▶ Positive-guided relay outputs:
 - 7 safety contacts (N/O), instantaneous
 - 1 auxiliary contact (N/C), instantaneous
- ▶ Connection options for:
 - E-STOP pushbutton
 - Safety gate limit switch
 - Reset button
- ▶ LED indicator for:
 - Switch status channel 1/2
 - Supply voltage
 - Reset circuit
 - Input circuits
- ▶ Semiconductor output signals:
 - Switch status channel 1/2
 - Supply voltage is present
- ▶ See order reference for unit types

Safety features

- The relay meets the following safety requirements:
- ▶ The circuit is redundant with built-in self-monitoring.
 - ▶ The safety function remains effective in the case of a component failure.
 - ▶ The correct opening and closing of the safety function relays is tested automatically in each on-off cycle.
 - ▶ The transformer is short circuit-proof.

Unit description

The safety relay meets the requirements of EN 60947-5-1, EN 60204-1 and VDE 0113-1 and may be used in applications with

- ▶ E-STOP pushbuttons
- ▶ Safety gates

Block diagram

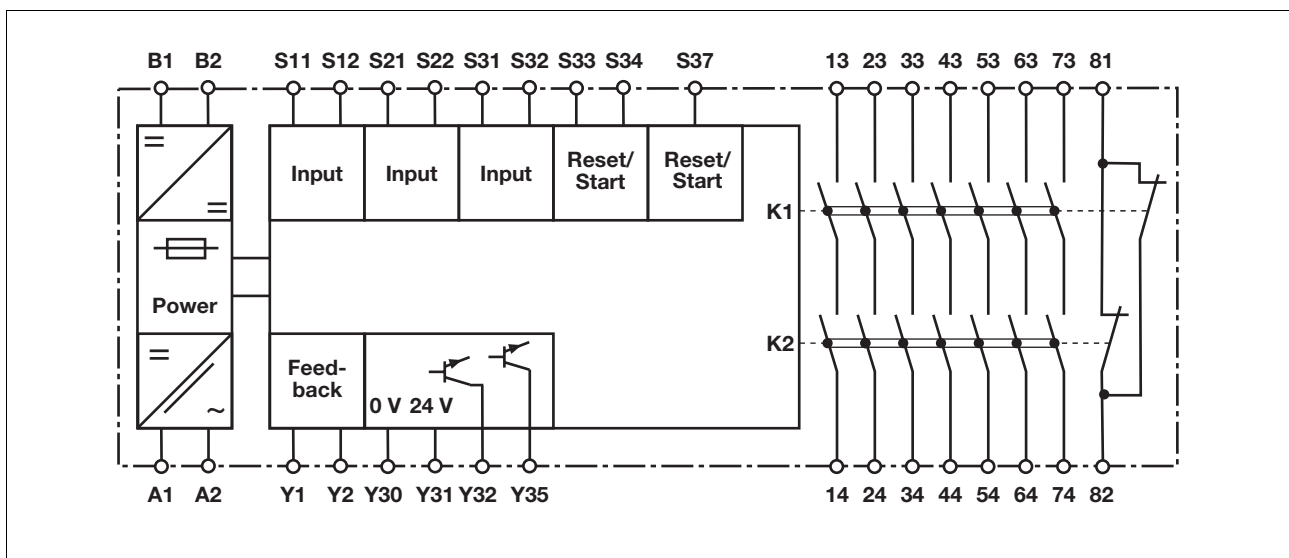

Up to PL e of EN ISO 13849-1 PNOZ 11

Function description

- ▶ Single-channel operation: no redundancy in the input circuit, earth faults in the reset circuit are detected.
- ▶ Dual-channel operation with detection of shorts across contacts: redundant input circuit, detects
 - earth faults in the reset and input circuit,
- short circuits in the input circuit and, with a monitored reset, in the reset circuit too,
- shorts between contacts in the input circuit.
- ▶ Automatic start: Unit is active once the input circuit has been closed.
- ▶ Manual reset: Unit is active once the input circuit is closed and then the reset circuit is closed.
- ▶ Monitored reset: Unit is active once
 - the input circuit is closed and then the reset circuit is closed and opened again.
 - the reset circuit is closed and then opened again once the input circuit is closed.
- ▶ Increase in the number of available instantaneous safety contacts by connecting contact expansion modules or external contactors.

Timing diagram

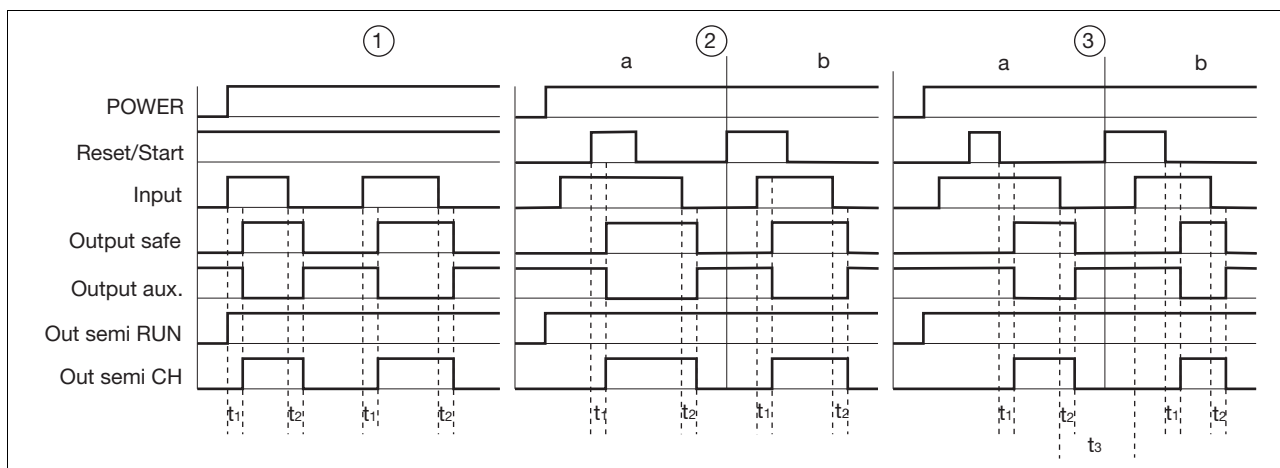

Key

- ▶ Power: Supply voltage
- ▶ Reset/Start: Reset circuit S33-S34, S34-S37
- ▶ Input: Input circuits S11-S12, S21-S22, S31-S32
- ▶ Output safe: Safety contacts 13-14, 23-24, 33-34, 43-44, 53-54, 63-64, 73-74
- ▶ Output aux: Auxiliary contacts 81-82
- ▶ Out semi RUN: Semiconductor output supply voltage Y35
- ▶ Out semi CH: Semiconductor output switch status Y32
- ▶ ①: Automatic reset
- ▶ ②: Manual reset
- ▶ ③: Monitored reset
- ▶ a: Input circuit closes before reset circuit
- ▶ b: Reset circuit closes before input circuit
- ▶ t_1 : Switch-on delay
- ▶ t_2 : Delay-on de-energisation
- ▶ t_3 : Recovery time

Wiring

Please note:

- ▶ Information given in the “Technical details” must be followed.
- ▶ Outputs 13-14, 23-24, 33-34, 43-44, 53-54, 63-64, 73-74 are safety contacts, output 81-82 is an auxiliary contact (e.g. for display).
- ▶ To prevent contact welding, a fuse should be connected before the output contacts (see technical details).
- ▶ Calculation of the max. cable runs l_{max} in the input circuit:

$$l_{max} = \frac{R_{lmax}}{R_l / km}$$

R_{lmax} = max. overall cable resistance (see technical details)
 R_l / km = cable resistance/km

- ▶ Use copper wire that can withstand 60/75 °C.
- ▶ Sufficient fuse protection must be provided on all output contacts with capacitive and inductive loads.

Up to PL e of EN ISO 13849-1 PNOZ 11

Preparing for operation

► Supply voltage

Supply voltage	AC	DC

► Input circuit

Input circuit	Single-channel	Dual-channel
E-STOP without detection of shorts across contacts		
E-STOP with detection of shorts across contacts		
Safety gate without detection of shorts across contacts		
Safety gate with detection of shorts across contacts		

Up to PL e of EN ISO 13849-1 PNOZ 11

▶ Reset circuit

Reset circuit	E-STOP wiring, safety gate	Safety gate (dual-channel)
Automatic reset		
Manual reset		
Monitored reset		

▶ Feedback loop



Feedback loop	Automatic reset	Manual/monitored reset:
Link		
Contacts from external contactors		

▶ Semiconductor output

--

Up to PL e of EN ISO 13849-1 PNOZ 11

► Key

S1	E-STOP pushbutton
S1/S2	Two-hand button
S1/S2	E-STOP/safety gate switch
S3	Reset button
	Switch operated
	Gate open
	Gate closed

Up to PL e of EN ISO 13849-1 PNOZ 11

Terminal configuration

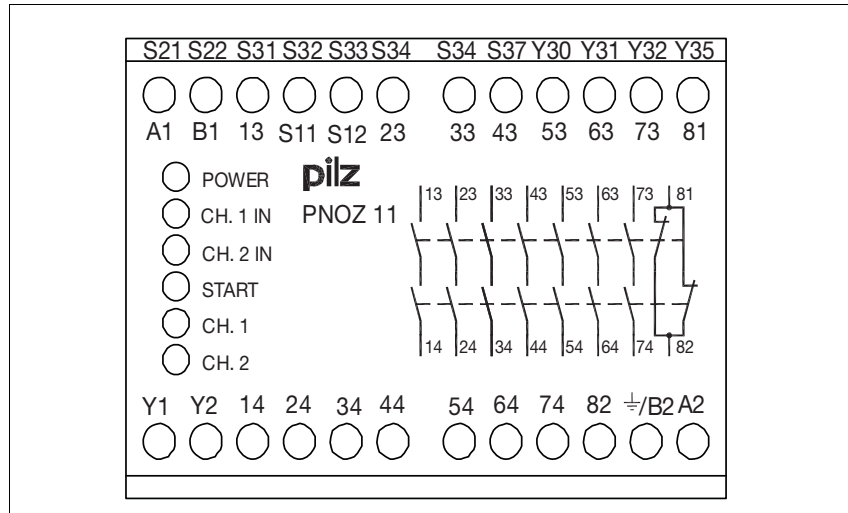

Installation

- ▶ The safety relay should be installed in a control cabinet with a protection type of at least IP54.
- ▶ Use the notch on the rear of the unit to attach it to a DIN rail.
- ▶ Ensure the unit is mounted securely on a vertical DIN rail (35 mm) by using a fixing element (e.g. retaining bracket or an end angle).

Dimensions

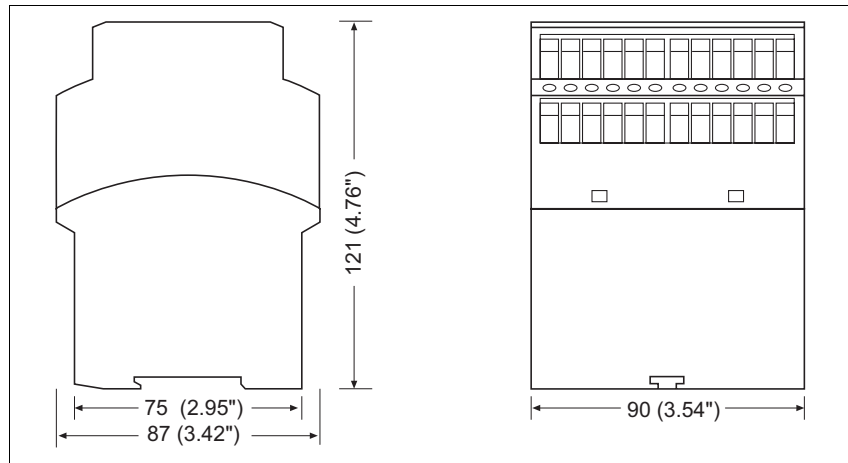

Up to PL e of EN ISO 13849-1 PNOZ 11

Notice

This data sheet is only intended for use during configuration. For installation and operation, please refer to the operating instructions supplied with the unit.

Service life graph

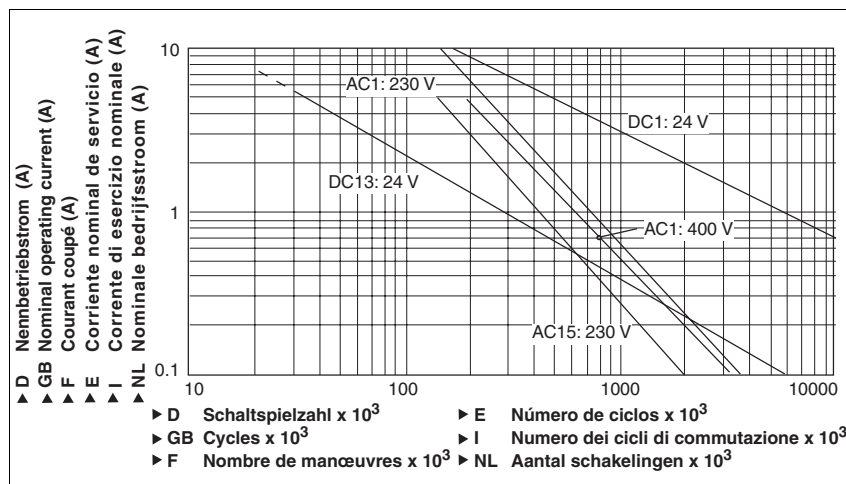

Technical details

Electrical data

Supply voltage	
Supply voltage U _B AC	24 V, 42 V, 48 V, 110 - 120 V, 230 - 240 V
Supply voltage U _B DC	24 V
Voltage tolerance	-15 %/+10 %
Power consumption at U _B AC	9.0 VA
Power consumption at U _B DC	3.5 W
Frequency range AC	50 - 60 Hz
Residual ripple DC	160 %
Voltage and current at	
Input circuit DC: 24.0 V	50.0 mA
Reset circuit DC: 24.0 V	45.0 mA
Feedback loop DC: 24.0 V	45.0 mA
Number of output contacts	
Safety contacts (S) instantaneous:	7
Auxiliary contacts (N/C):	1
Utilisation category in accordance with EN 60947-4-1	
Safety contacts: AC1 at 240 V	I _{min} : 0.01 A , I _{max} : 8.0 A P _{max} : 2000 VA
Safety contacts: AC1 at 400 V	I _{min} : 0.01 A , I _{max} : 5.00 A P _{max} : 2000 VA
Safety contacts: DC1 at 24 V	I _{min} : 0.01 A , I _{max} : 8.0 A P _{max} : 200 W
Auxiliary contacts: AC1 at 240 V	I _{min} : 0.01 A , I _{max} : 8.0 A P _{max} : 2000 VA
Auxiliary contacts: DC1 at 24 V	I _{min} : 0.01 A , I _{max} : 8.0 A P _{max} : 200 W
Utilisation category in accordance with EN 60947-5-1	
Safety contacts: AC15 at 230 V	I _{max} : 5.0 A
Safety contacts: DC13 at 24 V (6 cycles/min)	I _{max} : 7.0 A
Auxiliary contacts: AC15 at 230 V	I _{max} : 5.0 A
Auxiliary contacts: DC13 at 24 V (6 cycles/min)	I _{max} : 7.0 A
Contact material	AgSnO₂ + 0.2 µm Au

Up to PL e of EN ISO 13849-1 PNOZ 11

Electrical data	
External contact fuse protection ($I_k = 1 \text{ kA}$) to EN 60947-5-1	
Blow-out fuse, quick	
Safety contacts:	10 A
Auxiliary contacts:	10 A
Blow-out fuse, slow	
Safety contacts:	6 A
Auxiliary contacts:	6 A
Circuit breaker 24 VAC/DC, characteristic B/C	
Safety contacts:	6 A
Auxiliary contacts:	6 A
Semiconductor outputs (short circuit proof)	24.0 V DC, 20 mA
External supply voltage	24.0 V DC
Voltage tolerance	-20 %/+20 %
Max. overall cable resistance R_{lmax}	
input circuits, reset circuits	
single-channel at U_B DC	50 Ohm
single-channel at U_B AC	100 Ohm
dual-channel with detect. of shorts across contacts at U_B DC	15 Ohm
dual-channel with detect. of shorts across contacts at U_B AC	20 Ohm
Min. input resistance in the starting torque	43 Ohm
Safety-related characteristic data	
PL in accordance with EN ISO 13849-1	PL e (Cat. 4)
Category in accordance with EN 954-1	Cat. 4
SIL CL in accordance with EN IEC 62061	SIL CL 3
PFH in accordance with EN IEC 62061	2.31E-09
SIL in accordance with IEC 61511	SIL 3
PFD in accordance with IEC 61511	2.03E-06
t_M in years	20
Times	
Switch-on delay	
with automatic reset typ.	330 ms
with automatic reset max.	450 ms
with automatic reset after power on typ.	330 ms
with automatic reset after power on max.	480 ms
with manual reset typ.	335 ms
with manual reset max.	450 ms
on monitored reset with rising edge typ.	330 ms
on monitored reset with rising edge max.	450 ms
Delay-on de-energisation	
with E-STOP typ.	17 ms
with E-STOP max.	30 ms
with power failure typ.	40 ms
with power failure max.	60 ms
Recovery time at max. switching frequency 1/s	
after E-STOP	50 ms
after power failure	100 ms
Min. start pulse duration with a monitored reset	
with rising edge	30 ms
Simultaneity, channel 1 and 2	∞
Supply interruption before de-energisation	10 ms
Environmental data	
EMC	EN 60947-5-1, EN 61000-6-2
Vibration to EN 60068-2-6	
Frequency	10 - 55 Hz
Amplitude	0.35 mm
Climatic suitability	EN 60068-2-78

Up to PL e of EN ISO 13849-1 PNOZ 11

Environmental data	
Airgap creepage in accordance with EN 60947-1	
Pollution degree	2
Overvoltage category	III
Ambient temperature	-10 - 55 °C
Storage temperature	-40 - 85 °C
Protection type	
Mounting (e.g. cabinet)	IP54
Housing	IP40
Terminals	IP20
Mechanical data	
Housing material	
Housing	PPO UL 94 V0
Front	ABS UL 94 V0
Cross section of external conductors with screw terminals	
1 core flexible	0.20 - 4.00 mm ² , 24 - 10 AWG
2 core, same cross section, flexible:	
with crimp connectors, without insulating sleeve	0.20 - 2.50 mm ² , 24 - 14 AWG
without crimp connectors or with TWIN crimp connectors	0.20 - 2.50 mm ² , 24 - 14 AWG
Torque setting with screw terminals	0.60 Nm
Dimensions	
Height	87.0 mm
Width	90.0 mm
Depth	121.0 mm
Weight	640 g

The standards current on 09/01 apply.

Conventional thermal current		
Number of contacts	I_{th} (A) at U_B DC	I_{th} (A) at U_B AC
1	8.00 A	8.00 A
2	8.00 A	8.00 A
3	8.00 A	6.80 A
4	6.90 A	5.90 A
5	6.20 A	5.30 A
6	5.60 A	4.80 A
7	5.20 A	4.50 A

Order reference				
Type	Features		Terminals	Order no.
PNOZ 11	24 VAC	24 VDC	Screw terminals	774 080
PNOZ 11	42 VAC	24 VDC	Screw terminals	774 081
PNOZ 11	48 VAC	24 VDC	Screw terminals	774 082
PNOZ 11	110 - 120 VAC	24 VDC	Screw terminals	774 085
PNOZ 11	230 - 240 VAC	24 VDC	Screw terminals	774 086