

Up to PL e of EN ISO 13849-1 PNOZ X3.10P



Safety relay for monitoring E-STOP pushbuttons, safety gates and light beam devices

Approvals

PNOZ X3.10P	
	◆
	◆
	◆

Unit features

- ▶ Positive-guided relay outputs:
 - 3 safety contacts (N/O), instantaneous
 - 1 auxiliary contact (N/C), instantaneous
- ▶ 1 semiconductor output
- ▶ Connection options for:
 - E-STOP pushbutton
 - Safety gate limit switch
 - Reset button
 - Light barriers
- ▶ LED indicator for:
 - Switch status channel 1/2
 - Supply voltage
- ▶ Semiconductor output signals:
 - Switch status channel 1/2
- ▶ Plug-in connection terminals (either spring-loaded terminal or screw terminal)
- ▶ See order reference for unit types

Unit description

The safety relay meets the requirements of EN 60947-5-1, EN 60204-1 and VDE 0113-1 and may be used in applications with

- ▶ E-STOP pushbuttons
- ▶ Safety gates
- ▶ Light beam devices

Safety features

The relay meets the following safety requirements:

- ▶ The circuit is redundant with built-in self-monitoring.
- ▶ The safety function remains effective in the case of a component failure.
- ▶ The correct opening and closing of the safety function relays is tested automatically in each on-off cycle.

Block diagram

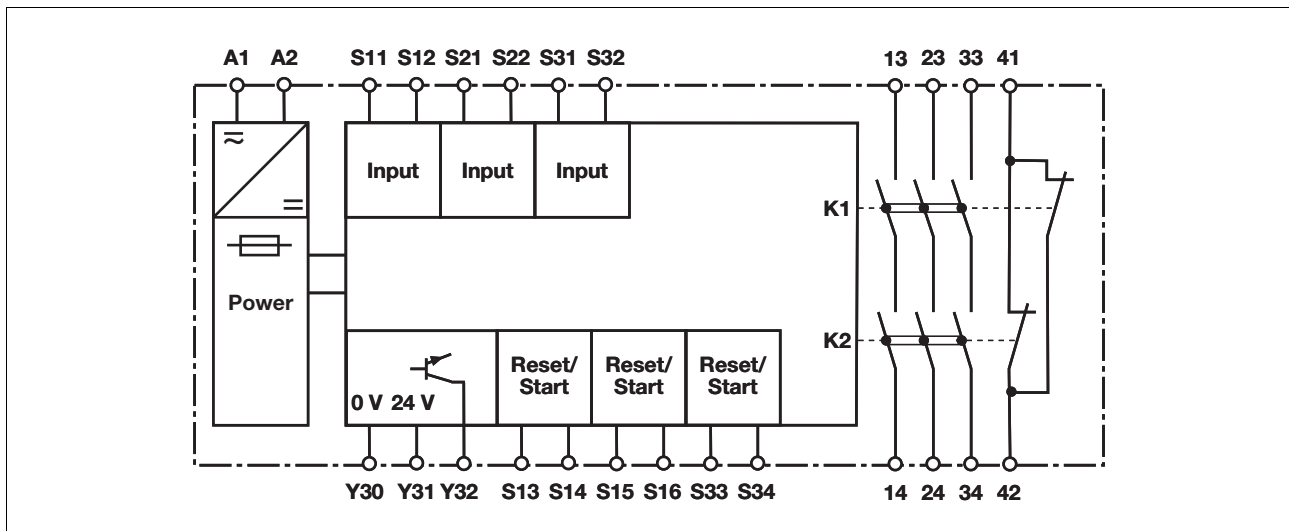

Up to PL e of EN ISO 13849-1 PNOZ X3.10P

Function description

- ▶ Single-channel operation: no redundancy in the input circuit, earth faults in the reset and input circuit are detected.
- ▶ Dual-channel operation with detection of shorts across contacts: redundant input circuit, detects
 - earth faults in the reset and input circuit,
- short circuits in the input circuit and, with a monitored reset, in the reset circuit too,
- shorts between contacts in the input circuit.
- ▶ Automatic start: Unit is active once the input circuit has been closed.
- ▶ Manual reset: Unit is active once the input circuit is closed and then the reset circuit is closed.
- ▶ Monitored reset: Unit is active once the input circuit is closed and once the reset circuit is closed after the waiting period has elapsed (see technical details).
- ▶ Increase in the number of available instantaneous safety contacts by connecting contact expansion modules or external contactors.

Timing diagram

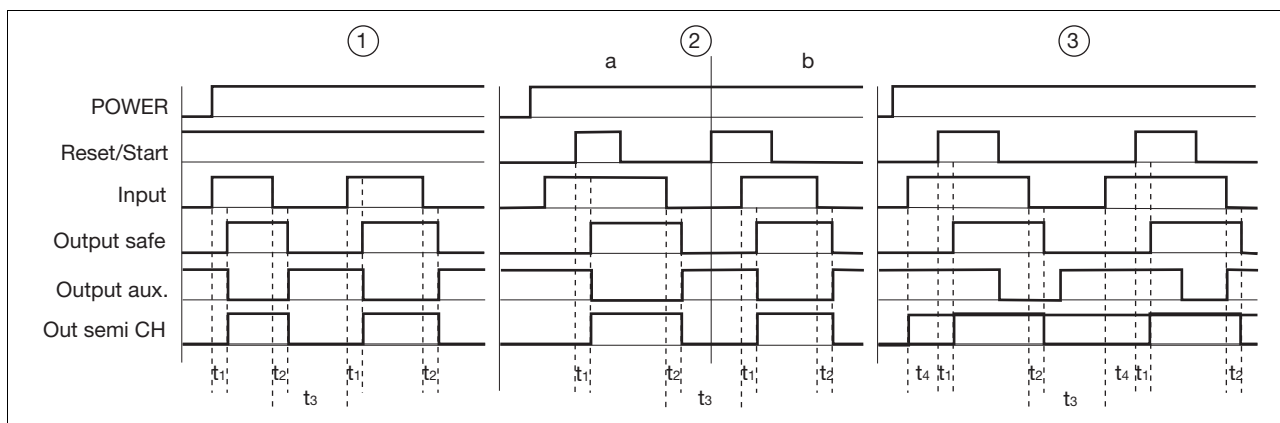

Key

- ▶ Power: Supply voltage
- ▶ Reset/Start: Reset circuit S13-S14, S33-S34
- ▶ Input: Input circuits S11-S12, S21-S22, S31-S32
- ▶ Output safe: Safety contacts 13-14, 23-24, 33-34
- ▶ Output aux.: Auxiliary contacts 41-42
- ▶ Out semi CH: Semiconductor output switch status Y32
- ▶ ①: Automatic reset
- ▶ ②: Manual reset
- ▶ ③: Monitored reset
- ▶ a: Input circuit closes before reset circuit
- ▶ b: Reset circuit closes before input circuit
- ▶ t_1 : Switch-on delay
- ▶ t_2 : Delay-on de-energisation
- ▶ t_3 : Recovery time
- ▶ t_4 : Waiting period

Wiring

Please note:

- ▶ Information given in the “Technical details” must be followed.
- ▶ Outputs 13-14, 23-24, 33-34 are safety contacts, output 41-42 is an auxiliary contact (e.g. for display).
- ▶ To prevent contact welding, a fuse should be connected before the output contacts (see technical details).
- ▶ Calculation of the max. cable runs I_{max} in the input circuit:

$$I_{max} = \frac{R_{lmax}}{R_l / km}$$

R_{lmax} = max. overall cable resistance (see technical details)

R_l / km = cable resistance/km

- ▶ Use copper wire that can withstand 60/75 °C.
- ▶ Sufficient fuse protection must be provided on all output contacts with capacitive and inductive loads.

Up to PL e of EN ISO 13849-1 PNOZ X3.10P

Preparing for operation

► Supply voltage

Supply voltage	AC	DC

► Input circuit

Input circuit	Single-channel	Dual-channel
E-STOP without detection of shorts across contacts		
E-STOP with detection of shorts across contacts		
Safety gate without detection of shorts across contacts		
Safety gate with detection of shorts across contacts		
Light beam device with detection of shorts across contacts via ESPE		

Up to PL e of EN ISO 13849-1 PNOZ X3.10P

▶ Reset circuit

Reset circuit	E-STOP wiring, safety gate	Safety gate (dual-channel) with start-up test
Automatic reset		
Manual reset		
Monitored reset		

▶ Feedback loop

Feedback loop	Automatic reset	Monitored reset
Contacts from external contactors		

▶ Semiconductor output

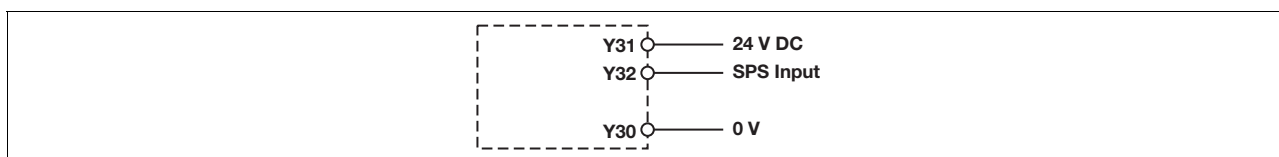

▶ Key

S1/S2	E-STOP/safety gate switch
S3	Reset button
	Switch operated
	Gate open
	Gate closed

Up to PL e of EN ISO 13849-1 PNOZ X3.10P

Terminal configuration

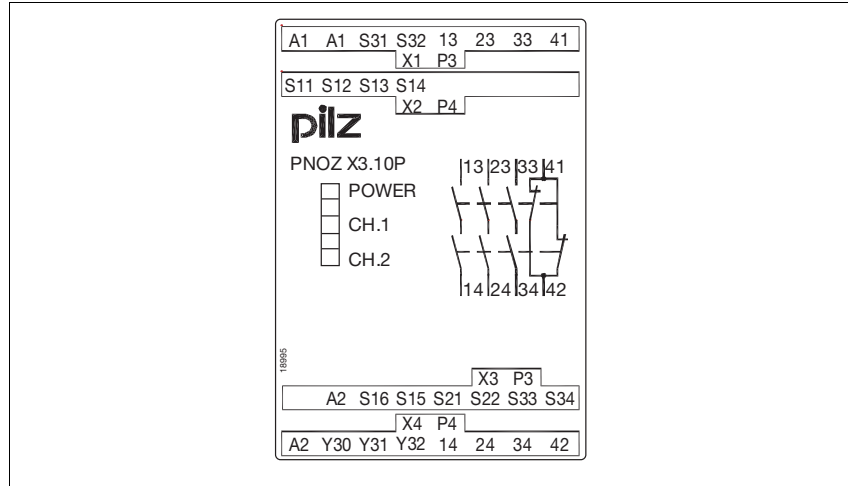

Installation

- ▶ The safety relay should be installed in a control cabinet with a protection type of at least IP54.
- ▶ Use the notch on the rear of the unit to attach it to a DIN rail.
- ▶ Ensure the unit is mounted securely on a vertical DIN rail (35 mm) by using a fixing element (e.g. retaining bracket or an end angle).

Dimensions

* with spring-loaded terminals

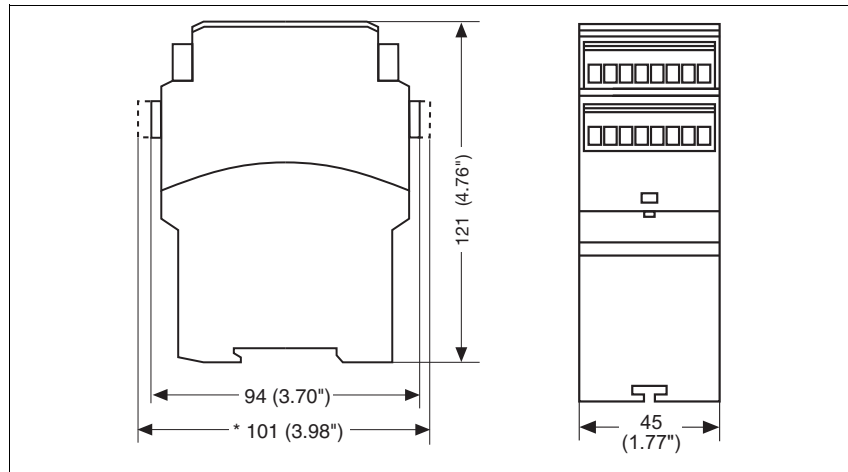

Up to PL e of EN ISO 13849-1 PNOZ X3.10P

Notice

This data sheet is only intended for use during configuration. Please refer to the operating manual for installation and operation.

Service life graph

The service life graphs indicate the number of cycles from which failures due to wear must be expected. The wear is mainly caused by the electrical load; the mechanical load is negligible.

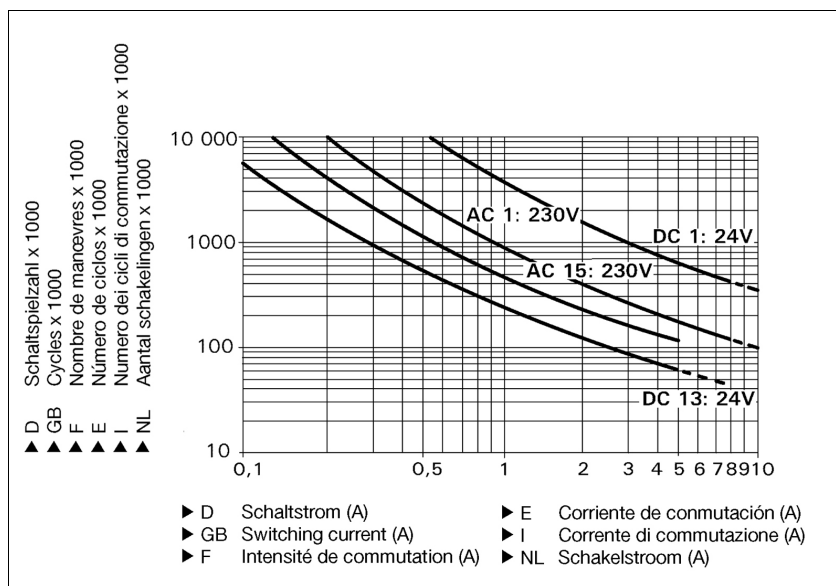

Example

- ▶ Inductive load: 0,2 A
- ▶ Utilisation category: AC15
- ▶ Contact service life: 4,000,000 cycles

Provided the application requires fewer than 4,000,000 cycles, the PFH value (see technical details) can be used in the calculation.

To increase the service life, sufficient spark suppression must be provided on all output contacts. With capacitive loads, any power surges that occur must be noted. With contactors, use freewheel diodes for spark suppression.

Technical details

Electrical data

Supply voltage	
Supply voltage U_B AC/DC	24 V
Voltage tolerance	-15 %/+10 %
Power consumption at U_B AC	5.0 VA
Power consumption at U_B DC	2.5 W
Frequency range AC	50 - 60 Hz
Residual ripple DC	160 %
Voltage and current at	
Input circuit DC: 24.0 V	40.0 mA
Reset circuit DC: 24.0 V	70.0 mA
Feedback loop DC: 24.0 V	20.0 mA
Number of output contacts	
Safety contacts (S) instantaneous:	3
Auxiliary contacts (N/C):	1

Up to PL e of EN ISO 13849-1 PNOZ X3.10P

Electrical data	
Utilisation category in accordance with EN 60947-4-1	
Safety contacts: AC1 at 240 V	I_{\min} : 0.01 A , I_{\max} : 8.0 A P_{\max} : 2000 VA
Safety contacts: DC1 at 24 V	I_{\min} : 0.01 A , I_{\max} : 8.0 A P_{\max} : 200 W
Auxiliary contacts: AC1 at 240 V	I_{\min} : 0.01 A , I_{\max} : 8.0 A P_{\max} : 2000 VA
Auxiliary contacts: DC1 at 24 V	I_{\min} : 0.01 A , I_{\max} : 8.0 A P_{\max} : 200 W
Utilisation category in accordance with EN 60947-5-1	
Safety contacts: AC15 at 230 V	I_{\max} : 5.0 A
Safety contacts: DC13 at 24 V (6 cycles/min)	I_{\max} : 6.0 A
Auxiliary contacts: AC15 at 230 V	I_{\max} : 5.0 A
Auxiliary contacts: DC13 at 24 V (6 cycles/min)	I_{\max} : 6.0 A
Contact material	AgSnO₂ + 0.2 µm Au
External contact fuse protection ($I_K = 1$ kA) to EN 60947-5-1	
Blow-out fuse, quick	
Safety contacts:	10 A
Auxiliary contacts:	10 A
Blow-out fuse, slow	
Safety contacts:	6 A
Auxiliary contacts:	6 A
Circuit breaker 24 VAC/DC, characteristic B/C	
Safety contacts:	6 A
Auxiliary contacts:	6 A
Semiconductor outputs (short circuit proof)	24.0 V DC, 20 mA
External supply voltage	24.0 V DC
Voltage tolerance	-20 %/+20 %
Max. overall cable resistance $R_{l\max}$ input circuits, reset circuits	
single-channel at U_B DC	150 Ohm
single-channel at U_B AC	180 Ohm
dual-channel without detect. of shorts across contacts at U_B DC	300 Ohm
dual-channel without detect. of shorts across contacts at U_B AC	360 Ohm
dual-channel with detect. of shorts across contacts at U_B DC	15 Ohm
dual-channel with detect. of shorts across contacts at U_B AC	30 Ohm
Min. input resistance when switching on	90 Ohm
Safety-related characteristic data	
PL in accordance with EN ISO 13849-1: 2006	PL e (Cat. 4)
Category in accordance with EN 954-1	Cat. 4
SIL CL in accordance with EN IEC 62061	SIL CL 3
PFH in accordance with EN IEC 62061	2.31E-09
SIL in accordance with IEC 61511	SIL 3
PFD in accordance with IEC 61511	2.03E-06
T_M [year] in accordance with EN ISO 13849-1: 2006	20
Times	
Switch-on delay	
with automatic reset typ.	250 ms
with automatic reset max.	500 ms
with automatic reset after power on typ.	280 ms
with automatic reset after power on max.	550 ms
with manual reset typ.	200 ms
with manual reset max.	500 ms
on monitored reset with rising edge typ.	35 ms
on monitored reset with rising edge max.	50 ms

Up to PL e of EN ISO 13849-1 PNOZ X3.10P

Times	
Delay-on de-energisation	
with E-STOP typ.	15 ms
with E-STOP max.	30 ms
with power failure typ.	180 ms
with power failure max.	260 ms
Recovery time at max. switching frequency 1/s	
after E-STOP	50 ms
after power failure	350 ms
Waiting period with a monitored reset	
with rising edge	300 ms
Min. start pulse duration with a monitored reset	
with rising edge	30 ms
Simultaneity, channel 1 and 2	∞
Supply interruption before de-energisation	150 ms
Environmental data	
EMC	EN 60947-5-1, EN 61000-6-2
Vibration to EN 60068-2-6	
Frequency	10 - 55 Hz
Amplitude	0.35 mm
Climatic suitability	EN 60068-2-78
Airgap creepage in accordance with EN 60947-1	
Pollution degree	2
Overvoltage category	III / II
Rated insulation voltage	250 V
Rated impulse withstand voltage	4.00 kV
Ambient temperature	-20 - 55 °C
Storage temperature	-40 - 85 °C
Protection type	
Mounting (e.g. cabinet)	IP54
Housing	IP40
Terminals	IP20
Mechanical data	
Housing material	
Housing	PPO UL 94 V0
Front	ABS UL 94 V0
Cross section of external conductors with screw terminals	
1 core flexible	0.25 - 2.50 mm ² , 24 - 12 AWG No. 777314
2 core, same cross section, flexible:	
with crimp connectors, without insulating sleeve	0.25 - 1.00 mm ² , 24 - 16 AWG No. 777314
without crimp connectors or with TWIN crimp connectors	0.20 - 1.50 mm ² , 24 - 16 AWG No. 777314
Torque setting with screw terminals	0.50 Nm No. 777314
Cross section of external conductors with spring-loaded terminals: Flexible with/without crimp connectors	0.20 - 1.50 mm ² , 24 - 16 AWG No. 787314
Spring-loaded terminals: Terminal points per connection	2 No. 787314
Stripping length	8 mm No. 787314
Dimensions	
Height	101.0 mm No. 787314 94.0 mm No. 777314
Width	45.0 mm
Depth	121.0 mm
Weight	290 g

No. stands for order number.

Up to PL e of EN ISO 13849-1 PNOZ X3.10P

It is essential to consider the relay's service life graphs. The relay outputs' safety-related characteristic data is only valid if the values in the service life graphs are met.

The PFH value depends on the switching frequency and the load on the relay output.

If the service life graphs are not accessible, the stated PFH value can be

used irrespective of the switching frequency and the load, as the PFH value already considers the relay's B10d value as well as the failure rates of the other components.

All the units used within a safety function must be considered when calculating the safety characteristic data.

INFORMATION

A safety function's SIL/PL values are **not** identical to the SIL/PL values of the units that are used and may be different. We recommend that you use the PAScal software tool to calculate the safety function's SIL/PL values.

The standards current on **2009-11** apply.

Conventional thermal current while loading several contacts

Number of contacts	I_{th} per contact at U_B DC	I_{th} at U_B AC
1	8.00 A	8.00 A
2	8.00 A	7.00 A
3	7.00 A	6.00 A

Order reference

Type	Features	Terminals	Order no.
PNOZ X3.10P C	24 VAC/DC	Spring-loaded terminals	787 314
PNOZ X3.10P	24 VAC/DC	Screw terminals	777 314