

Schaltertype / Switch type: A2/8T/F911

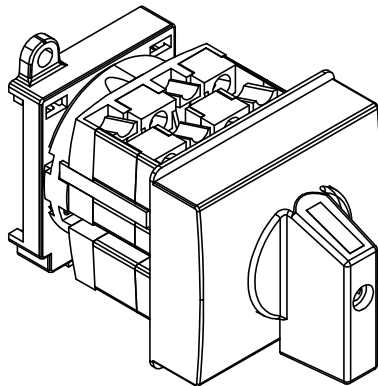

lth  
 AC23 (400V)  
 AC3 (400V)  
 Anschlussquerschnitt / Connection cross: max  
 Drehmoment Klemmen / Torque clamps:

25A  
 7,5kW  
 5,5kW  
 4mm<sup>2</sup>  
 1,2Nm