

Datasheet - AZM 200ST1-T-1P2PWA

Solenoid interlock / AZM 200



(Minor differences between the printed image and the original product may exist!)

- Guard locking monitored
- thermoplastic enclosure
- Electronic contact-free, coded system
- Connector M23 8+1-pole,
- Max. length of the sensor chain 200 m
- Self-monitoring series-wiring of 31 sensors
- 3 LEDs to show operating conditions
- Sensor technology permits an offset between actuator and interlock of ± 5 mm vertically and ± 3 mm horizontally
- Intelligent diagnosis
- Manual release

Ordering details

Product type description	AZM 200ST1-T-1P2PWA
Article number	AZM 200ST1-T-1P2PWA
EAN code	

Approval

Approval



Classification

Standards	EN ISO 13849-1, IEC 61508, IEC 60947-5-3
PL	bis e
Control category	bis 4
PFH	$4.0 \times 10^{-9}/h$
SIL	bis 3
Mission time	20 Years
Classification	PDF-M

Global Properties

Product name	AZM 200
--------------	---------

Standards	EN 60947-5-1, IEC 61508, EN ISO 13849-1, EN ISO 13849-1
Compliance with the Directives (Y/N) 	Yes
Suitable for safety functions (Y/N)	Yes
Protection rating	II
Series-wiring	up to 31 components
Length of the sensor chain	max. 200 m
Active principle	inductive
Duty cycle	100 %
Materials	
- Material of the housings	Plastic, glass-fibre reinforced thermoplastic
Housing coating	None
Weight	557 g
Guard locking monitored (Y/N)	Yes
Actuator monitored (Y/N)	No
Idle assignable pushbutton and LED (Y/N)	No
Reaction time	≤ 60 ms
Duration of risk	> 120 ms
Time to readiness	4000 ms
Recommended actuator	AZ/AZM 200-B1

Mechanical data

Design of electrical connection	Connector M23, 8+1-pole
Mechanical life	≥ 1.000.000 operations
resistance to shock	30 g / 11 ms
Resistance to vibration	10 ... 55 Hz, Amplitude 1 mm
Emergency unlocking device (Y/N)	No
Manual release (Y/N)	Yes
Emergency release (Y/N)	No
Latching force	30 N
Clamping force F_{max}	2000 N
Max. Actuating speed	≤ 0,2 m/s

Ambient conditions

Ambient temperature	
- Min. environmental temperature	-25 °C
- Max. environmental temperature	+50 °C
Storage and transport temperature	
- Min. Storage and transport temperature	-25 °C
- Max. Storage and transport temperature	+85 °C
Relative humidity	30% ... 95%
- non-condensing	
Protection class	IP67 to IEC/EN 60529
Air clearances and creepage distances To IEC/EN 60664-1	
- Rated impulse withstand voltage U_{imp}	0,8 kV
- Overvoltage category	III
- Degree of pollution	3

Electrical data

Number of auxiliary contacts	0 piece
Number of safety contacts	2 piece
Cross circuit/short circuit recognition possible (Y/N)	Yes

Power to unlock	No
Power to lock	Yes
Supply voltage U_B	
- Min. supply voltage	20.4 VDC
- Max. supply voltage	26.4 VDC
Switch frequency	1 Hz
Rated insulation voltage U_i	32 VDC
Operating current I_e	1.2 A
Utilisation category	DC-12, DC-13
No-load current I_0	0,6 A
Device insulation	≤ 4 A

Electrical data - Safety inputs

Safety inputs	X1 and X2
Rated operating voltage U_e	- 3 V ... 5 V (Low) 15 V ... 30 V (High)
Operating current I_e	> 2 mA / 24 V

Electrical data - Safety outputs

Safety outputs	Y1 and Y2
Fuse rating	short-circuit proof, p-type
Rated operating voltage	0 V ... 4 V under Supply voltage U_B
Residual current I_r	$\leq 0,5$ mA
Operating current I_e	0,25 A
Utilisation category	DC-12, DC-13

Electrical data - Diagnostic output

Serial diagnostics (Y/N)	No
Fuse rating	p-type, short-circuit proof
Operating current I_e	0,05 A
Utilisation category	DC-12, DC-13
Wiring capacitance for serial diagnostics	-
diagnostic signals	guard door closed and interlocking device locked
Operating principle of the diagnostic output	The short-circuit proof diagnostic output OUT can be used for central visualisation or control tasks, e.g. in a PLC.
notice	The diagnostic output is not a safety-relevant output!

Electrical data - Solenoid control IN

Rated operating voltage U_e	- 3 V ... 5 V (Low) 15 V ... 30 V (High)
Operating current I_e	typically 10 mA / 24 V, dynamically 20 mA

LED switching conditions display

LED switching conditions display (Y/N)	Yes
LED switching conditions display	
- Supply voltage U_B	green LED
- switching condition	yellow LED
- Error functional defect	red LED

ATEX

Explosion protection categories for gases	None
Explosion protected category for dusts	None

Dimensions

Dimensions of the sensor	
- Width of sensor	40 mm
- Height of sensor	220 mm
- Length of sensor	50 mm

Pin assignment

1	A1 Supply voltage U _B
2	X1 Safety input 1
3	A2 GND
4	Y1 Safety output 1
5	OUT Diagnostic output
6	X2 Safety input 2
7	Y2 Safety output 2
8	IN Solenoid control
9	without function

notice

As long as the actuating unit remains inserted in the solenoid interlock, the unlocked safety guard can be relocked. The safety outputs then will be enabled again; opening the safety guard therefore is not required.

Included in delivery

Included in delivery	AZM 200 Triangular key
----------------------	---------------------------

Actuators must be ordered separately.

Indication legend

see drawing: Wiring example

With the represented power-to-unlock principle, the solenoid is energised to enable the opening.

With the alternative power-to-lock principle (not represented), the solenoid must be energised to keep the device in closed condition.

Ordering code

AZM 200(1)-T-(2)(3)(4)

(1)

without

B Guard locking monitored

Actuator monitored

(2)

SK Screw connection

CC Spring pulley connection

ST1 connector M23 x 1, (8+1-pole)

ST2 connector M12 x 1, 8-pole

(3)

1P2P	1 Diagnostic output and 2 Safety outputs, p-type
1P2PW	gleich - 1P2P, combined diagnostic signal: guard door closed and interlocking device locked
SD2P	serial diagnostic output and 2 Safety outputs, p-type
(4)	
<i>without</i>	Power to unlock
A	Power to lock

Documents

Operating instructions and Declaration of conformity (pl) 332 kB, 10.07.2013

Code: mrl_azm200t_pl

Operating instructions and Declaration of conformity (jp) 416 kB, 20.02.2013

Code: mrl_azm200t_jp

Operating instructions and Declaration of conformity (es) 311 kB, 26.07.2013

Code: mrl_azm200t_es

Operating instructions and Declaration of conformity (en) 309 kB, 09.01.2013

Code: mrl_azm200t_en

Operating instructions and Declaration of conformity (pt) 346 kB, 26.06.2012

Code: mrl_azm200t_pt

Operating instructions and Declaration of conformity (fr) 304 kB, 29.05.2013

Code: mrl_azm200t_fr

Operating instructions and Declaration of conformity (it) 306 kB, 20.02.2013

Code: mrl_azm200t_it

Operating instructions and Declaration of conformity (de) 314 kB, 09.01.2013

Code: mrl_azm200t_de

Operating instructions and Declaration of conformity (nl) 292 kB, 03.06.2013

Code: mrl_azm200t_nl

Operating instructions and Declaration of conformity (da) 312 kB, 22.08.2013

Code: mrl_azm200t_da

Operating instructions and Declaration of conformity (sv) 340 kB, 19.03.2012

Code: mrl_azm200t_sv

Wiring example (99) 21 kB, 12.01.2009

Code: kazm2l26

Diagnosis tables (en) 136 kB, 12.01.2009

Code: b_tabp02

Diagnosis tables (de) 135 kB, 12.01.2009

Code: b_tabp01

TÜV certification (en, de) 914 kB, 10.08.2012

Code: z_azmp04

Images

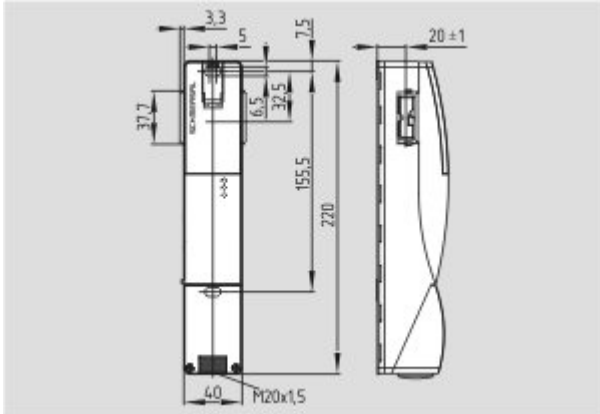

Dimensional drawing (miscellaneous)

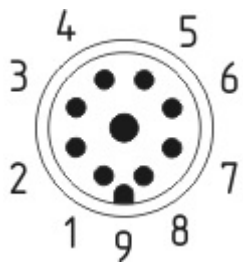

Contact arrangement

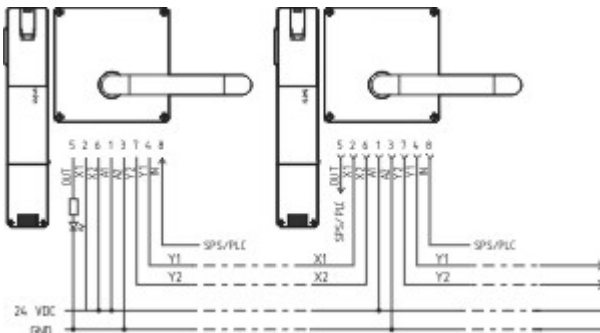

Wiring example

System components

Actuator



101183465 - AZ/AZM 200-B1-LT

- Actuators with return spring
 - Actuator for sliding guards
 - Tolerates up to max. 5 mm overtravel
-

101183466 - AZ/AZM 200-B1-LTP0

- Actuators with return spring
- Actuator for sliding guards
- Tolerates up to max. 5 mm overtravel



101183469 - AZ/AZM 200-B1-RT

- Actuators with return spring
- Actuator for sliding guards
- Tolerates up to max. 5 mm overtravel

101183470 - AZ/AZM 200-B1-RTP0

- Actuators with return spring
- Actuator for sliding guards
- Tolerates up to max. 5 mm overtravel

101178681 - AZ/AZM 200-B30-LTAG1

- Actuator for hinged guards
- With door detection sensor T
- Easy and intuitive operation
- No risk of injury from protruding actuator
- No supplementary door handles required
- Does not protrude into the door opening
- Various handles available

101178668 - AZ/AZM 200-B30-LTAG1P1

- One-hand emergency exit, even in de-energised condition
- Actuator for hinged guards
- With door detection sensor T
- Easy and intuitive operation
- No risk of injury from protruding actuator
- No supplementary door handles required
- Does not protrude into the door opening
- Various handles available

101186150 - AZ/AZM 200-B30-LTAG1P20

- One-hand emergency exit, even in de-energised condition
- Actuator for hinged guards
- With door detection sensor T
- Easy and intuitive operation
- No risk of injury from protruding actuator
- No supplementary door handles required
- Does not protrude into the door opening
- Various handles available

101192102 - AZ/AZM 200-B30-LTAG1P25

- One-hand emergency exit, even in de-energised condition
- Actuator for hinged guards
- With door detection sensor T
- Easy and intuitive operation
- No risk of injury from protruding actuator

- No supplementary door handles required
- Does not protrude into the door opening
- Various handles available

101181137 - AZ/AZM 200-B30-LTAG2

- Actuator for hinged guards
- With door detection sensor T
- Easy and intuitive operation
- No risk of injury from protruding actuator
- No supplementary door handles required
- Does not protrude into the door opening
- Various handles available

101181141 - AZ/AZM 200-B30-LTAG2P1

- One-hand emergency exit, even in de-energised condition
- Actuator for hinged guards
- With door detection sensor T
- Easy and intuitive operation
- No risk of injury from protruding actuator
- No supplementary door handles required
- Does not protrude into the door opening
- Various handles available

101189020 - AZ/AZM 200-B30-LTAG2P20

- One-hand emergency exit, even in de-energised condition
- Actuator for hinged guards
- With door detection sensor T
- Easy and intuitive operation
- No risk of injury from protruding actuator
- No supplementary door handles required
- Does not protrude into the door opening
- Various handles available

101192106 - AZ/AZM 200-B30-LTAG2P25

- One-hand emergency exit, even in de-energised condition
- Actuator for hinged guards
- With door detection sensor T
- Easy and intuitive operation
- No risk of injury from protruding actuator
- No supplementary door handles required
- Does not protrude into the door opening
- Various handles available

101178680 - AZ/AZM 200-B30-RTAG1

- Actuator for hinged guards
- With door detection sensor T
- Easy and intuitive operation
- No risk of injury from protruding actuator
- No supplementary door handles required
- Does not protrude into the door opening
- Various handles available

101178738 - AZ/AZM 200-B30-RTAG1P1

- One-hand emergency exit, even in de-energised condition
- Actuator for hinged guards
- With door detection sensor T



- Easy and intuitive operation
- No risk of injury from protruding actuator
- No supplementary door handles required
- Does not protrude into the door opening
- Various handles available

101186144 - AZ/AZM 200-B30-RTAG1P20



- One-hand emergency exit, even in de-energised condition
- Actuator for hinged guards
- With door detection sensor T
- Easy and intuitive operation
- No risk of injury from protruding actuator
- No supplementary door handles required
- Does not protrude into the door opening
- Various handles available

101192103 - AZ/AZM 200-B30-RTAG1P25



- One-hand emergency exit, even in de-energised condition
- Actuator for hinged guards
- With door detection sensor T
- Easy and intuitive operation
- No risk of injury from protruding actuator
- No supplementary door handles required
- Does not protrude into the door opening
- Various handles available

101181139 - AZ/AZM 200-B30-RTAG2



- Actuator for hinged guards
- With door detection sensor T
- Easy and intuitive operation
- No risk of injury from protruding actuator
- No supplementary door handles required
- Does not protrude into the door opening
- Various handles available

101181143 - AZ/AZM 200-B30-RTAG2P1



- One-hand emergency exit, even in de-energised condition
- Actuator for hinged guards
- With door detection sensor T
- Easy and intuitive operation
- No risk of injury from protruding actuator
- No supplementary door handles required
- Does not protrude into the door opening
- Various handles available

101191659 - AZ/AZM 200-B30-RTAG2P20



- One-hand emergency exit, even in de-energised condition
- Actuator for hinged guards
- With door detection sensor T
- Easy and intuitive operation
- No risk of injury from protruding actuator
- No supplementary door handles required
- Does not protrude into the door opening

- Various handles available



101192104 - AZ/AZM 200-B30-RTAG2P25

- One-hand emergency exit, even in de-energised condition
- Actuator for hinged guards
- With door detection sensor T
- Easy and intuitive operation
- No risk of injury from protruding actuator
- No supplementary door handles required
- Does not protrude into the door opening
- Various handles available

Connector



A-K9M23

- Pre-wired cable
- 8+1-pole



S-K9M23

- Connector without cable
- with shrink connection
- 8+1-pole

K.A. Schmersal GmbH & Co. KG, Möddinghofe 30, D-42279 Wuppertal

The data and values have been checked thoroughly. Technical modifications and errors excepted.

Generiert am 23.01.2014 - 17:28:49h Kasbase 2.2.18.F DBI

Image

Image
et=sS
e