

ATV930D30N4

variable speed drive - ATV930 - 30kW -
400/480V - with braking unit - IP21



Main

Range of product	Altivar Process ATV900
Product or component type	Variable speed drive
Device application	Industrial application
Device short name	ATV930
Variant	Standard version
Product destination	Asynchronous motors Synchronous motors
Mounting mode	Wall mount
EMC filter	Integrated conforming to EN/IEC 61800-3 category C3 with 150 m motor cable maxi Integrated conforming to EN/IEC 61800-3 category C2 with 50 m motor cable maxi
IP degree of protection	IP21 conforming to IEC 60529 IP21 conforming to IEC 61800-5-1
Degree of protection	UL type 1 conforming to UL 508C
Type of cooling	Forced convection
Supply frequency	50...60 Hz (+/- 5 %)
Network number of phases	3 phases
[Us] rated supply voltage	380...480 V (- 15...10 %)
Motor power kW	22 kW (heavy duty) 30 kW (normal duty)
Motor power hp	30 hp (heavy duty) 40 hp (normal duty)
Line current	35.8 A at 480 V (heavy duty) 40.5 A at 380 V (heavy duty) 45.9 A at 480 V (normal duty) 53.3 A at 380 V (normal duty)
Prospective line I _{sc}	50 kA
Apparent power	29.8 kVA at 480 V (heavy duty) 38.1 kVA at 480 V (normal duty)
Continuous output current	46.3 A at 4 kHz (heavy duty) 61.5 A at 4 kHz (normal duty)
Maximum transient current	69.5 A during 60 s (heavy duty) 73.8 A during 60 s (normal duty)
Asynchronous motor control profile	Constant torque standard Variable torque standard Optimized torque mode
Synchronous motor control profile	Permanent magnet motor
Speed drive output frequency	0.1...500 Hz
Nominal switching frequency	4 kHz
Switching frequency	4...16 kHz with derating factor 2...16 kHz adjustable
Safety function	STO (safe torque off) SIL 3
Number of preset speeds	16 preset speeds

The information provided in this documentation contains general descriptions and/or technical characteristics of the performance of the products contained herein. This documentation is not intended as a substitute for and is not to be used for determining suitability or reliability of these products for specific user applications. It is the duty of any such user or integrator to perform the appropriate and complete risk analysis, evaluation and testing of the products with respect to the relevant specific application or use thereof. Neither Schneider Electric Industries SAS nor any of its affiliates or subsidiaries shall be responsible or liable for misuse of the information contained herein.

Communication port protocol	Modbus serial Modbus TCP Ethernet IP
Option module	Slot B: resolver encoder interface module Slot B: analog encoder interface module Slot B: 5/12 V digital encoder interface module Slot A/slot B/slot C: output relay extension module Slot A/slot B/slot C: digital and analog I/O extension module Slot A: communication module for CANopen screw terminals Slot A: communication module for CANopen SUB-D 9 Slot A: communication module for CANopen daisy chain RJ45 Slot A: communication module for EtherCAT Slot A: communication module for DeviceNet Slot A: communication module for Profinet Slot A: communication module for Profibus DP V1

Complementary

Output voltage	\leq power supply voltage
Motor slip compensation	Adjustable Automatic whatever the load Can be suppressed Not available in permanent magnet motor law
Acceleration and deceleration ramps	Linear adjustable separately from 0.01 to 9000 s S, U or customized
Braking to standstill	By DC injection
Protection type	Drive: break on the control circuit Drive: overspeed Drive: line supply phase loss Drive: line supply undervoltage Drive: line supply overvoltage Drive: overvoltages on the DC bus Drive: motor phase break Drive: short-circuit protection Drive: overload of output voltage Drive: overcurrent between output phases and earth Drive: overheating Drive: safe torque off Drive: thermal protection Motor: motor phase break Motor: safe torque off Motor: thermal protection
Frequency resolution	Analog input: 0.012/50 Hz Display unit: 0.1 Hz
Electrical connection	DC bus, screw terminal: 25...50 mm ² (AWG 4...AWG 1) Motor, screw terminal: 25...50 mm ² (AWG 4...AWG 1) Line side, screw terminal: 25...50 mm ² (AWG 4...AWG 1) Control, screw terminal: 0.5...1.5 mm ² (AWG 20...AWG 16)
Type of connector	1 RJ45 (on the control block) for Modbus serial 2 RJ45 (on the control block) for Ethernet IP/Modbus TCP
Physical interface	2-wire RS 485 for Modbus serial
Transmission frame	RTU for Modbus serial
Transmission rate	4.8, 9.6, 19.2, 38.4 kbit/s for Modbus serial 10/100 Mbit/s for Ethernet IP/Modbus TCP
Exchange mode	Half duplex, full duplex, autonegotiation for Ethernet IP/Modbus TCP
Data format	8 bits, configurable odd, even or no parity for Modbus serial
Type of polarization	No impedance for Modbus serial
Number of addresses	1...247 for Modbus serial
Method of access	Slave for Modbus TCP
Supply	Internal supply for digital inputs and STO: 24 V DC (21...27 V) current \leq 200 mA (overload and short-circuit protection) Internal supply for reference potentiometer (1 to 10 kOhm): 10.5 V DC \pm 5 % current \leq 10 mA (overload and short-circuit protection) External supply for digital inputs: 24 V DC (19...30 V) current \leq 1.25 mA (overload and short-circuit protection)

Local signalling	1 LED(s) red for presence of voltage 2 LED(s) dual colour for communication module status 5 LED(s) dual colour for embedded communication status 3 LED(s) mono/dual colour for local diagnostic
Width	226 mm
Height	673 mm
Depth	274 mm
Product weight	28 kg
Analogue input number	3
Analogue input type	Software-configurable current AI1, AI2, AI3: 0...20 mA impedance 250 Ohm, resolution 12 bits Software-configurable voltage AI1, AI2, AI3: 0...10 V DC impedance 30 kOhm, resolution 12 bits
Discrete input number	10
Discrete input type	Safe torque off STO A, STOB: 24 V DC (≤ 30 V) impedance > 2.2 kOhm Programmable as pulse input DI7, DI8 0...30 kHz: 24 V DC (≤ 30 V) Programmable DI1...DI8: 24 V DC (≤ 30 V) impedance 3.5 kOhm
Input compatibility	Discrete input STOA, STOB : level 1 PLC conforming to EN/IEC 61131-2 Pulse input DI7, DI8 : level 1 PLC conforming to IEC 65A-68 Discrete input DI1...DI8 : level 1 PLC conforming to EN/IEC 61131-2
Discrete input logic	STOA, STOB, positive logic (source): < 5 V (state 0) > 11 V (state 1) DI7, DI8, positive logic (source): < 0.6 V (state 0) > 2.5 V (state 1) DI1...DI8, negative logic (sink): > 16 V (state 0) < 10 V (state 1) DI1...DI8, positive logic (source): < 5 V (state 0) > 11 V (state 1)
Analogue output number	2
Analogue output type	Software-configurable current AQ1, AQ2: 0...20 mA impedance 500 Ohm, resolution 10 bits Software-configurable voltage AQ1, AQ2: 0...10 V DC impedance 470 Ohm, resolution 10 bits
Discrete output number	2
Discrete output type	Logic output DQ-: 0...1 kHz (≤ 30 V) DC, < 100 mA Programmable as pulse output DQ+: 0...30 kHz (≤ 30 V) DC, < 20 mA Logic output DQ+: 0...1 kHz (≤ 30 V) DC, < 100 mA
Sampling duration	Analog output AQ1, AQ2 : 5 ms (+/- 1 ms) Analog input AI1, AI2, AI3 : 1 ms (+/- 1 ms) Pulse input DI7, DI8 : 5 ms (+/- 1 ms) Discrete input DI1...DI8 : 2 ms (+/- 0.5 ms)
Accuracy	Analog output AQ1, AQ2 : +/- 1 % for a temperature variation 60 °C Analog input AI1, AI2, AI3 : +/- 0.6 % for a temperature variation 60 °C
Linearity error	Analog output AQ1, AQ2 : +/- 0.2 % Analog input AI1, AI2, AI3 : +/- 0.15 % of maximum value
Relay output number	3
Relay output type	Configurable relay logic R3 : sequence relay NO electrical durability 1000000 cycles Configurable relay logic R2 : sequence relay NO electrical durability 1000000 cycles Configurable relay logic R1 : fault relay NO/NC electrical durability 100000 cycles
Refresh time	Relay output R1, R2, R3 : 5 ms (+/- 0.5 ms)
Minimum switching current	Relay output R1, R2, R3 : 5 mA at 24 V DC
Maximum switching current	Relay output R2, R3 on inductive load ($\cos \phi = 0.4$ and $L/R = 7$ ms) : 2 A at 30 V DC Relay output R2, R3 on inductive load ($\cos \phi = 0.4$ and $L/R = 7$ ms) : 2 A at 250 V AC Relay output R2, R3 on resistive load ($\cos \phi = 1$) : 5 A at 30 V DC Relay output R2, R3 on resistive load ($\cos \phi = 1$) : 5 A at 250 V AC Relay output R1 on inductive load ($\cos \phi = 0.4$ and $L/R = 7$ ms) : 2 A at 30 V DC Relay output R1 on inductive load ($\cos \phi = 0.4$ and $L/R = 7$ ms) : 2 A at 250 V AC Relay output R1 on resistive load ($\cos \phi = 1$) : 3 A at 30 V DC Relay output R1 on resistive load ($\cos \phi = 1$) : 3 A at 250 V AC
Isolation	Between power and control terminals
IP degree of protection	IP21

Environment

Insulation resistance	> 1 mOhm at 500 V DC for 1 minute to earth
Noise level	71.5 dB conforming to 86/188/EEC
Power dissipation in W	640 W (forced convection) at 380 V switching frequency 4 kHz 93 W (natural convection) at 380 V switching frequency 4 kHz
Volume of cooling air	240 m ³ /h
Operating position	Vertical +/- 10 degree
THDI	<= 48 % from 80...100 % of load conforming to IEC 61000-3-12
Electromagnetic compatibility	Conducted radio-frequency immunity test level 3 conforming to IEC 61000-4-6 1.2/50 μ s - 8/20 μ s surge immunity test level 3 conforming to IEC 61000-4-5 Electrical fast transient/burst immunity test level 4 conforming to IEC 61000-4-4 Radiated radio-frequency electromagnetic field immunity test level 3 conforming to IEC 61000-4-3 Electrostatic discharge immunity test level 3 conforming to IEC 61000-4-2
Pollution degree	2 EN/IEC 61800-5-1
Vibration resistance	1 gn (f = 13...200 Hz) conforming to IEC 60068-2-6 1.5 mm peak to peak (f = 2...13 Hz) conforming to IEC 60068-2-6
Shock resistance	15 gn during 11 ms conforming to IEC 60068-2-27
Relative humidity	5...95 % without condensation conforming to IEC 60068-2-3
Ambient air temperature for operation	50...60 °C with derating factor -15...50 °C without derating
Ambient air temperature for storage	-40...70 °C
Operating altitude	1000...4800 m with current derating 1 % per 100 m <= 1000 m without derating
Environmental characteristic	Dust pollution resistance class 3S3 conforming to EN/IEC 60721-3-3 Chemical pollution resistance class 3C3 conforming to EN/IEC 60721-3-3
Standards	IEC 13849-1 IEC 61508 IEC 60721-3 IEC 61000-3-12 EN/IEC 61800-5-1 EN/IEC 61800-3 (environment 2 category C3) EN/IEC 61800-3 (environment 1 category C2) EN/IEC 61800-3 UL 508C
Product certifications	CSA TÜV UL REACH
Marking	CE

Dimensions

IP21 / UL Type 1 Drives - Front, Left Side and Rear View

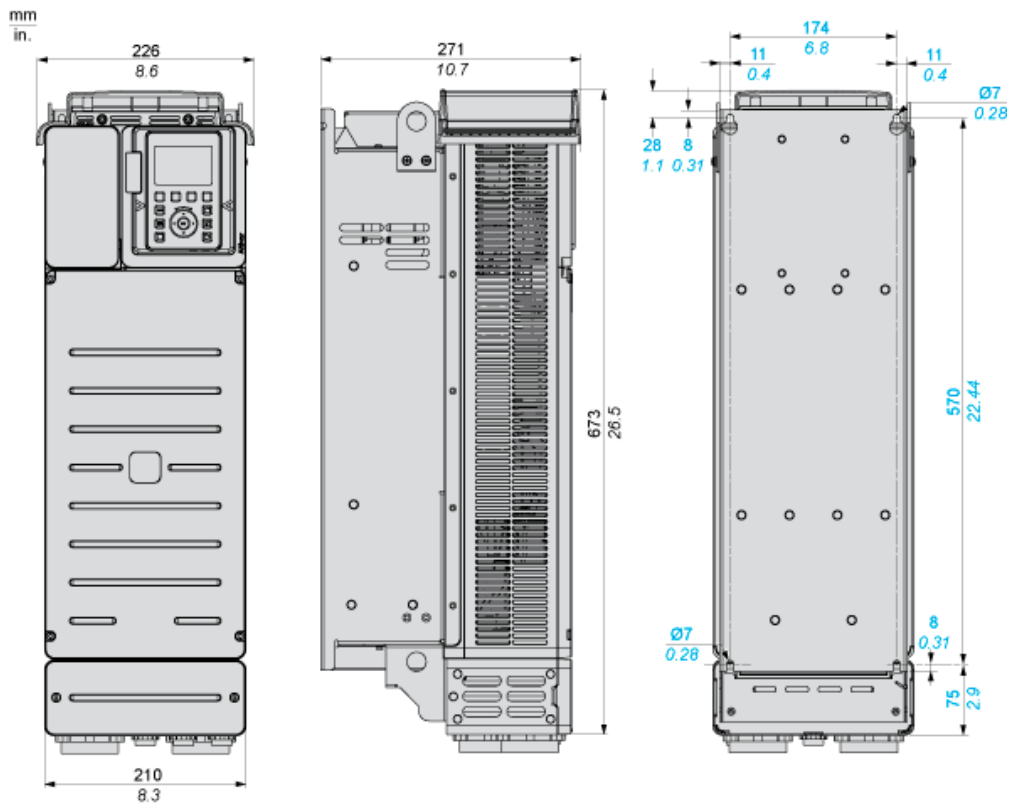

Clearances

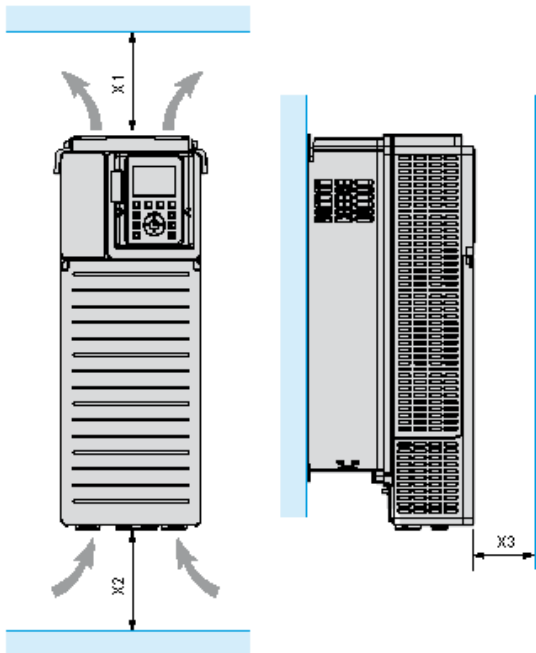

X1	X2	X3
≥ 100 mm (3.94 in.)	≥ 100 mm (3.94 in.)	≥ 10 mm (0.39 in.)

- Mount the device in a vertical position ($\pm 10^\circ$). This is required for cooling the device.
- Do not mount the device close to heat sources.
- Leave sufficient free space so that the air required for cooling purposes can circulate from the bottom to the top of the drive.

Mounting Types

Mounting Type A: Individual IP21

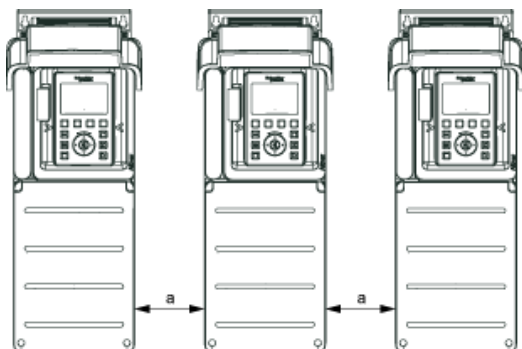

$a \geq 110 \text{ mm (4.33 in.)}$

Mounting Type B: Side by Side IP20 (Possible, 2 Drives Only)

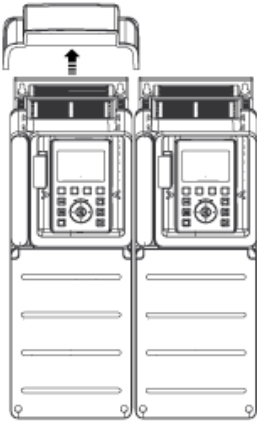

Mounting Type C: Individual IP20

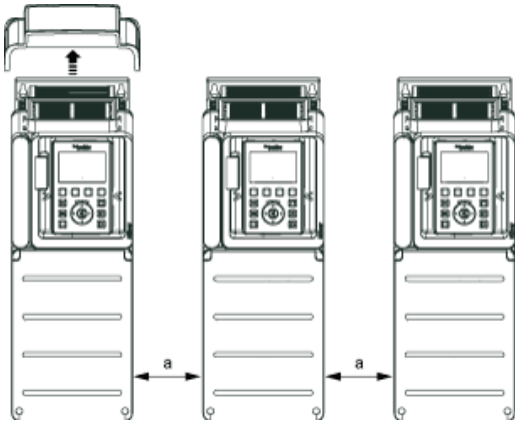

$a \geq 110 \text{ mm (4.33 in.)}$