



Main

Range of product	Altivar Process ATV900
Product or component type	Variable speed drive
Device application	Industrial application
Device short name	ATV930
Variant	Standard version
Product destination	Asynchronous motors Synchronous motors
Mounting mode	Wall mount
EMC filter	Integrated conforming to EN/IEC 61800-3 category C2 with 50 m motor cable maxi Integrated conforming to EN/IEC 61800-3 category C3 with 150 m motor cable maxi
IP degree of protection	IP21 conforming to IEC 61800-5-1 IP21 conforming to IEC 60529
Degree of protection	UL type 1 conforming to UL 508C
Type of cooling	Forced convection
Supply frequency	50...60 Hz (+/- 5 %)
Network number of phases	3 phases
[Us] rated supply voltage	380...480 V (- 15...10 %)
Motor power kW	5.5 kW (normal duty) 4 kW (heavy duty)
Motor power hp	7.5 hp (normal duty) 5 hp (heavy duty)
Line current	10.4 A at 380 V (normal duty) 9.1 A at 480 V (normal duty) 8 A at 380 V (heavy duty) 7.2 A at 480 V (heavy duty)
Prospective line I _{sc}	50 kA
Apparent power	7.6 kVA at 480 V (normal duty) 6 kVA at 480 V (heavy duty)
Continuous output current	12.7 A at 4 kHz (normal duty) 9.3 A at 4 kHz (heavy duty)
Maximum transient current	15.2 A during 60 s (normal duty)

	14 A during 60 s (heavy duty)
Asynchronous motor control profile	Constant torque standard Variable torque standard Optimized torque mode
Synchronous motor control profile	Permanent magnet motor
Speed drive output frequency	0.1...500 Hz
Nominal switching frequency	4 kHz
Switching frequency	2...16 kHz adjustable 4...16 kHz with derating factor
Safety function	STO (safe torque off) SIL 3
Discrete input logic	16 preset speeds
Communication port protocol	Modbus serial Modbus TCP Ethernet IP
Option card	Slot A : communication module for Profibus DP V1 Slot A : communication module for Profinet Slot A : communication module for DeviceNet Slot A : communication module for CANopen daisy chain RJ45 Slot A : communication module for CANopen SUB-D 9 Slot A : communication module for CANopen screw terminals Slot A : communication module for EtherCAT Slot A/slot B/slot C : digital and analog I/O extension module Slot A/slot B/slot C : output relay extension module Slot B : 5/12 V digital encoder interface module Slot B : analog encoder interface module Slot B : resolver encoder interface module

Complementary

Output voltage	<= power supply voltage
Motor slip compensation	Adjustable Automatic whatever the load Can be suppressed Not available in permanent magnet motor law
Acceleration and deceleration ramps	Linear adjustable separately from 0.01 to 9000 s S, U or customized
Braking to standstill	By DC injection
Protection type	Motor : thermal protection Motor : safe torque off Motor : motor phase break Drive : thermal protection Drive : safe torque off Drive : overheating Drive : overcurrent between output phases and earth Drive : overload of output voltage Drive : short-circuit protection Drive : motor phase break Drive : overvoltages on the DC bus Drive : line supply overvoltage Drive : line supply undervoltage Drive : line supply phase loss Drive : overspeed Drive : break on the control circuit
Frequency resolution	Display unit : 0.1 Hz Analog input : 0.012/50 Hz
Electrical connection	Control, screw terminal : 0.5...1.5 mm ² (AWG 20...AWG 16) DC bus, screw terminal : 2.5...6 mm ² (AWG 14...AWG 10) Line side, screw terminal : 2.5...6 mm ² (AWG 14...AWG 10) Motor, screw terminal : 4...6 mm ² (AWG 12...AWG 10)
Type of connector	2 RJ45 (on the control block) for Ethernet IP/Modbus TCP 1 RJ45 (on the control block) for Modbus serial
Physical interface	2-wire RS 485 for Modbus serial
Transmission frame	RTU for Modbus serial
Transmission rate	10/100 Mbit/s for Ethernet IP/Modbus TCP 4.8, 9.6, 19.2, 38.4 kbit/s for Modbus serial
Exchange mode	Half duplex, full duplex, autonegotiation for Ethernet IP/Modbus TCP

Data format	8 bits, configurable odd, even or no parity for Modbus serial
Type of polarization	No impedance for Modbus serial
Number of addresses	1...247 for Modbus serial
Method of access	Slave for Modbus TCP
Supply	External supply for digital inputs : 24 V DC (19...30 V) current \leq 1.25 mA (overload and short-circuit protection) Internal supply for reference potentiometer (1 to 10 kOhm) : 10.5 V DC \pm 5 % current \leq 10 mA (overload and short-circuit protection) Internal supply for digital inputs and STO : 24 V DC (21...27 V) current \leq 200 mA (overload and short-circuit protection)
Local signalling	3 LED(s) mono/dual colour for local diagnostic 5 LED(s) dual colour for embedded communication status 2 LED(s) dual colour for communication module status 1 LED(s) red for presence of voltage
Width	144 mm
Height	350 mm
Depth	206 mm
Product weight	4.7 kg
Analogue input number	3
Analogue input type	Software-configurable voltage AI1, AI2, AI3 : 0...10 V DC impedance 30 kOhm, resolution 12 bits Software-configurable current AI1, AI2, AI3 : 0...20 mA impedance 250 Ohm, resolution 12 bits
Discrete input number	10
Discrete input type	Programmable DI1...DI8 : 24 V DC (\leq 30 V) impedance 3.5 kOhm Programmable as pulse input DI7, DI8 0...30 kHz : 24 V DC (\leq 30 V) Safe torque off STOA, STOB : 24 V DC (\leq 30 V) impedance $>$ 2.2 kOhm
Input compatibility	Discrete input STOA, STOB : level 1 PLC conforming to EN/IEC 61131-2 Discrete input DI1...DI8 : level 1 PLC conforming to EN/IEC 61131-2 Pulse input DI7, DI8 : level 1 PLC conforming to IEC 65A-68
Discrete input logic	STOA, STOB, positive logic (source) : $<$ 5 V (state 0) $>$ 11 V (state 1) DI1...DI8, positive logic (source) : $<$ 5 V (state 0) $>$ 11 V (state 1) DI1...DI8, negative logic (sink) : $>$ 16 V (state 0) $<$ 10 V (state 1) DI7, DI8, positive logic (source) : $<$ 0.6 V (state 0) $>$ 2.5 V (state 1)
Analogue output number	2
Analogue output type	Software-configurable voltage AQ1, AQ2 : 0...10 V DC impedance 470 Ohm, resolution 10 bits Software-configurable current AQ1, AQ2 : 0...20 mA impedance 500 Ohm, resolution 10 bits
Discrete output number	2
Discrete output type	Logic output DQ+ : 0...1 kHz (\leq 30 V) DC, $<$ 100 mA Programmable as pulse output DQ+ : 0...30 kHz (\leq 30 V) DC, $<$ 20 mA Logic output DQ- : 0...1 kHz (\leq 30 V) DC, $<$ 100 mA
Sampling duration	Discrete input DI1...DI8 : 2 ms (\pm 0.5 ms) Pulse input DI7, DI8 : 5 ms (\pm 1 ms) Analog input AI1, AI2, AI3 : 1 ms (\pm 1 ms) Analog output AQ1, AQ2 : 5 ms (\pm 1 ms)
Accuracy	Analog input AI1, AI2, AI3 : \pm 0.6 % for a temperature variation 60 °C Analog output AQ1, AQ2 : \pm 1 % for a temperature variation 60 °C
Linearity error	Analog input AI1, AI2, AI3 : \pm 0.15 % of maximum value Analog output AQ1, AQ2 : \pm 0.2 %
Relay output number	3
Relay output type	Configurable relay logic R1 : fault relay NO/NC electrical durability 100000 cycles Configurable relay logic R2 : sequence relay NO electrical durability 1000000 cycles Configurable relay logic R3 : sequence relay NO electrical durability 1000000 cycles
Refresh time	Relay output R1, R2, R3 : 5 ms (\pm 0.5 ms)
Minimum switching current	Relay output R1, R2, R3 : 5 mA at 24 V DC
Maximum switching current	Relay output R1 on inductive load ($\cos \phi = 0.4$ and $L/R = 7$ ms) : 2 A at 250 V AC Relay output R1 on inductive load ($\cos \phi = 0.4$ and $L/R = 7$ ms) : 2 A at 30 V DC Relay output R2, R3 on inductive load ($\cos \phi = 0.4$ and $L/R = 7$ ms) : 2 A at 250 V AC Relay output R2, R3 on inductive load ($\cos \phi = 0.4$ and $L/R = 7$ ms) : 2 A at 30 V DC Relay output R1 on resistive load ($\cos \phi = 1$) : 3 A at 250 V AC Relay output R1 on resistive load ($\cos \phi = 1$) : 3 A at 30 V DC Relay output R2, R3 on resistive load ($\cos \phi = 1$) : 5 A at 250 V AC Relay output R2, R3 on resistive load ($\cos \phi = 1$) : 5 A at 30 V DC
Isolation	Between power and control terminals
Specific application	Process

IP degree of protection	IP21
-------------------------	------

Environment

Insulation resistance	> 1 mOhm at 500 V DC for 1 minute to earth
Noise level	54.5 dB conforming to 86/188/EEC
Power dissipation in W	36 W (natural convection) at 380 V switching frequency 4 kHz 145 W (forced convection) at 380 V switching frequency 4 kHz
Volume of cooling air	38 m3/h
Operating position	Vertical +/- 10 degree
THDI	<= 48 % full load conforming to IEC 61000-3-12
Electromagnetic compatibility	1.2/50 µs - 8/20 µs surge immunity test level 3 conforming to IEC 61000-4-5 Electrical fast transient/burst immunity test level 4 conforming to IEC 61000-4-4 Electrostatic discharge immunity test level 3 conforming to IEC 61000-4-2 Radiated radio-frequency electromagnetic field immunity test level 3 conforming to IEC 61000-4-3 Conducted radio-frequency immunity test level 3 conforming to IEC 61000-4-6
Pollution degree	2 EN/IEC 61800-5-1
Vibration resistance	1.5 mm peak to peak (f = 2...13 Hz) conforming to IEC 60068-2-6 1 gn (f = 13...200 Hz) conforming to IEC 60068-2-6
Shock resistance	15 gn during 11 ms conforming to IEC 60068-2-27
Relative humidity	5...95 % without condensation conforming to IEC 60068-2-3
Ambient air temperature for operation	-15...50 °C without derating 50...60 °C with derating factor
Ambient air temperature for storage	-40...70 °C
Operating altitude	1000...4800 m with current derating 1 % per 100 m <= 1000 m without derating
Environmental characteristic	Chemical pollution resistance class 3C3 conforming to EN/IEC 60721-3-3 Dust pollution resistance class 3S3 conforming to EN/IEC 60721-3-3
Standards	EN/IEC 61800-3 UL 508C EN/IEC 61800-5-1 IEC 61000-3-12 IEC 60721-3 IEC 61508 IEC 13849-1 EN/IEC 61800-3 (environment 1 category C2) EN/IEC 61800-3 (environment 2 category C3)
Product certifications	CSA TÜV UL REACH
Marking	CE

Offer Sustainability

Sustainable offer status	Green Premium product
RoHS (date code: YYWW)	Compliant - since 1526 - Schneider Electric declaration of conformity Schneider Electric declaration of conformity
REACH	Reference contains SVHC above the threshold - Go to CaP for more details Go to CaP for more details
Product environmental profile	Available
Product end of life instructions	Available

Dimensions

IP21 / UL Type 1 Drives - Right Side, Front and Rear View

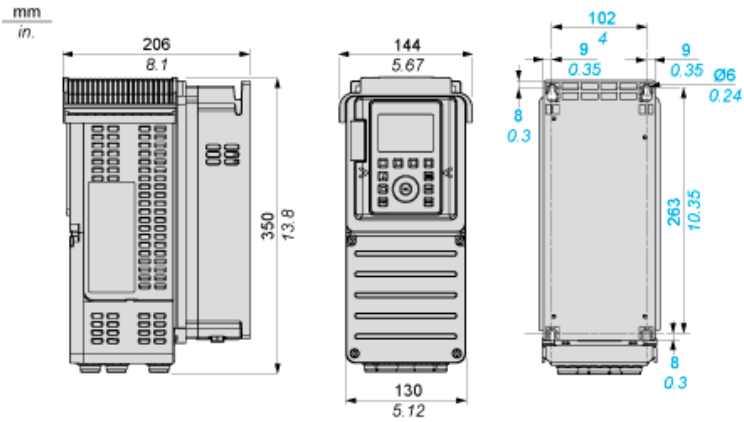

Clearances

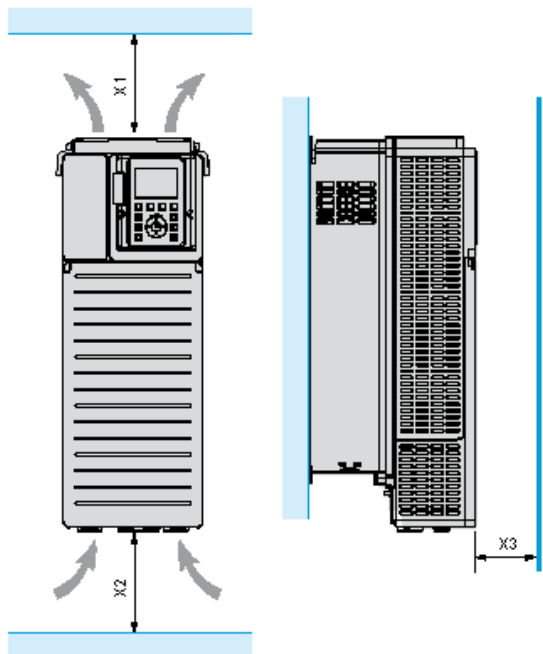

X1	X2	X3
≥ 100 mm (3.94 in.)	≥ 100 mm (3.94 in.)	≥ 10 mm (0.39 in.)

- Mount the device in a vertical position ($\pm 10^\circ$). This is required for cooling the device.
- Do not mount the device close to heat sources.
- Leave sufficient free space so that the air required for cooling purposes can circulate from the bottom to the top of the drive.

Mounting Types

Mounting Type A: Individual IP21

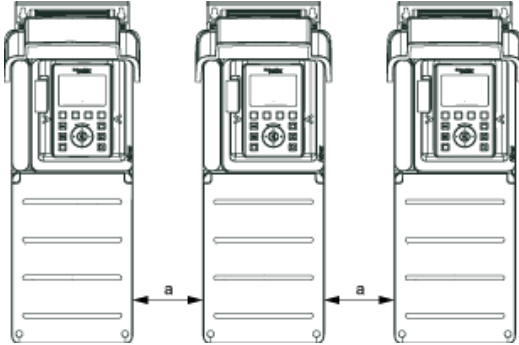

$a \geq 100 \text{ mm (3.94 in.)}$

Mounting Type B: Side by Side IP20

