



### Main

Range of product	Modicon TM3
Product or component type	Analog input module
Range compatibility	Modicon M251 Modicon M221 Modicon M241
Analogue input number	4
Analogue input type	Current, analogue input range: 4...20 mA Current, analogue input range: 0...20 mA Voltage, analogue input range: 0...10 V Voltage, analogue input range: - 10...10 V Thermocouple, analogue input range: - 200...1000 °C with thermocouple J Thermocouple, analogue input range: - 200...1300 °C with thermocouple K Thermocouple, analogue input range: 0...1760 °C with thermocouple R Thermocouple, analogue input range: 0...1760 °C with thermocouple S Thermocouple, analogue input range: 0...1820 °C with thermocouple B Thermocouple, analogue input range: - 200...400 °C with thermocouple T Thermocouple, analogue input range: - 200...1300 °C with thermocouple N Thermocouple, analogue input range: - 200...800 °C with thermocouple E Thermocouple, analogue input range: 0...2315 °C with thermocouple C Pt 100 temperature probe, analogue input range: - 200...850 °C Pt 1000 temperature probe, analogue input range: - 200...600 °C

### Complementary

Analogue input resolution	15 bits + sign 16 bits
Permissible continuous overload	13 V voltage 40 mA current
Input impedance	<= 50 Ohm current >= 1 MOhm temperature probe >= 1 MOhm thermocouple >= 1 MOhm voltage
LSB value	2.44 mV, analogue input: 0...10 V voltage 4.88 mV, analogue input: - 10...10 V voltage 4.88 µA, analogue input: 0...20 mA current 3.91 µA, analogue input: 4...20 mA current 0.1 °C temperature probe

	0.1 °C thermocouple
Conversion time	100 ms + 100 ms per channel + 1 controller cycle time for analogue input thermocouple 100 ms + 100 ms per channel + 1 controller cycle time for analogue input temperature probe 10 ms + 10 ms per channel + 1 controller cycle time for analogue input voltage/current
Sampling duration	10 ms for analogue input voltage/current 100 ms for analogue input voltage/current 100 ms for analogue input thermocouple 100 ms for analogue input temperature probe
Absolute accuracy error	+/- 1 % of full scale +/- 6 °C at 0...200 °C for thermocouple R +/- 6 °C at 0...200 °C for thermocouple S +/- 0.4 % of full scale at <= 0 °C for thermocouple K +/- 0.4 % of full scale at <= 0 °C for thermocouple J +/- 0.4 % of full scale at <= 0 °C for thermocouple E +/- 0.4 % of full scale at <= 0 °C for thermocouple T +/- 0.4 % of full scale at <= 0 °C for thermocouple N +/- 0.2 % of full scale at 25 °C for analogue input voltage/current +/- 0.2 % of full scale for thermocouple C +/- 0.2 % of full scale for Pt 100/Pt 1000, Ni 100/ Ni 1000 temperature probe
Temperature drift	+/- 0.01 %FS/°C
Repeat accuracy	+/-0.5 %FS
Non-linearity	+/- 0.2 %FS
Cross talk	<= 1 LSB
[Us] rated supply voltage	24 V DC
Supply voltage limits	20.4...28.8 V
Type of cable	<= 30 m twisted shielded pairs cable for input circuit
Current consumption	45 mA at 5 V DC via bus connector 50 mA at 5 V DC via bus connector 35 mA at 24 V DC via external supply 40 mA at 24 V DC via external supply
Local signalling	1 LED green for PWR
Electrical connection	10 x 1.5 mm <sup>2</sup> removable screw terminal block with pitch 3.81 mm adjustment for inputs and supply 10 x 1.5 mm <sup>2</sup> removable screw terminal block with pitch 3.81 mm adjustment for inputs
Insulation	500 V AC between input and internal logic 1500 V AC between input and supply
Marking	CE
Surge withstand	1 kV for power supply with common mode protection conforming to EN/IEC 61000-4-5 0.5 kV for power supply with differential mode protection conforming to EN/IEC 61000-4-5 1 kV for input with common mode protection conforming to EN/IEC 61000-4-5
Mounting support	Top hat type TH35-15 rail conforming to IEC 60715 Top hat type TH35-7.5 rail conforming to IEC 60715 Plate or panel with fixing kit
Height	90 mm
Depth	70 mm
Width	23.6 mm
Product weight	0.1 kg

## Environment

Standards	EN/IEC 61131-2 EN/IEC 61010-2-201
Resistance to electrostatic discharge	4 kV on contact conforming to EN/IEC 61000-4-2 8 kV in air conforming to EN/IEC 61000-4-2
Resistance to electromagnetic fields	10 V/m at 80 MHz...1 GHz conforming to EN/IEC 61000-4-3 3 V/m at 1.4 GHz...2 GHz conforming to EN/IEC 61000-4-3 1 V/m at 2 GHz...3 GHz conforming to EN/IEC 61000-4-3
Resistance to magnetic fields	30 A/m at 50...60 Hz conforming to EN/IEC 61000-4-8
Resistance to fast transients	1 kV I/O conforming to EN/IEC 61000-4-4
Resistance to conducted disturbances, induced by radio frequency fields	10 V at 0.15...80 MHz conforming to EN/IEC 61000-4-6 3 V at spot frequency (2, 3, 4, 6.2, 8.2, 12.6, 16.5, 18.8, 22, 25 MHz) conforming to Marine specification (LR, ABS, DNV, GL)
Electromagnetic emission	Radiated emissions, test level: 40 dBµV/m QP class A (10 m at 30...230 MHz) conforming to EN/IEC 55011

Radiated emissions, test level: 47 dBµV/m QP class A (10 m at 230 MHz...1 GHz) conforming to EN/ IEC 55011

Immunity to microbreaks	10 ms
Ambient air temperature for operation	-10...55 °C (horizontal installation) -10...35 °C (vertical installation)
Ambient air temperature for storage	-25...70 °C
Relative humidity	10...95 % without condensation in operation 10...95 % without condensation in storage
IP degree of protection	IP20
Pollution degree	2
Operating altitude	0...2000 m
Storage altitude	0...3000 m
Vibration resistance	3.5 mm at 5...8.4 Hz with DIN rail mounting support 3 gn at 8.4...150 Hz with DIN rail mounting support
Shock resistance	15 gn during 11 ms

### Offer Sustainability

Sustainable offer status	Green Premium product
RoHS (date code: YYWW)	Compliant - since 1415 - Schneider Electric declaration of conformity <a href="#">Schneider Electric declaration of conformity</a>
REACH	Reference not containing SVHC above the threshold <a href="#">Reference not containing SVHC above the threshold</a>
Product environmental profile	Available <a href="#">Product environmental</a>
Product end of life instructions	Available <a href="#">End of life manual</a>

Dimensions

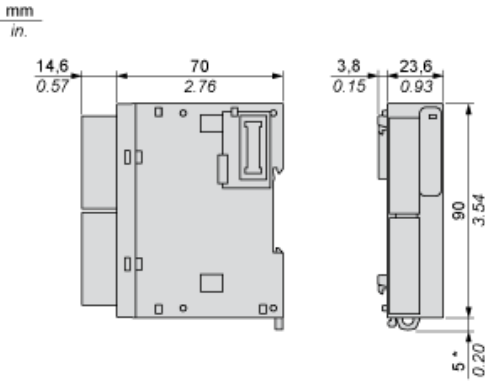

(\*) 8.5 mm/0.33 in when the clamp is pulled out.

Spacing Requirements

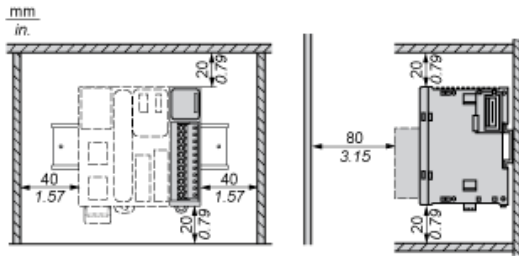

---

Mounting on a Rail

---

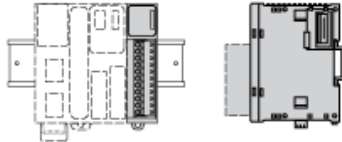

Incorrect Mounting



---

Mounting on a Panel Surface

---

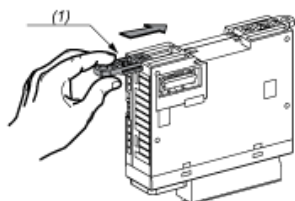

(1) Install a mounting strip

Mounting Hole Layout

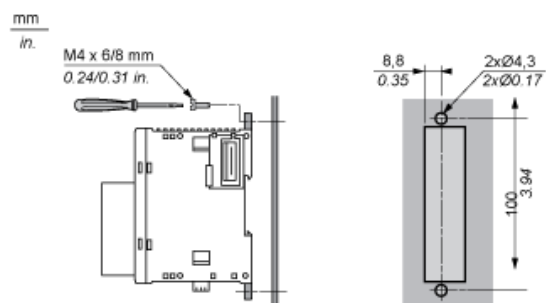

Analogue Input Module

Wiring Diagram (Current/Voltage type)

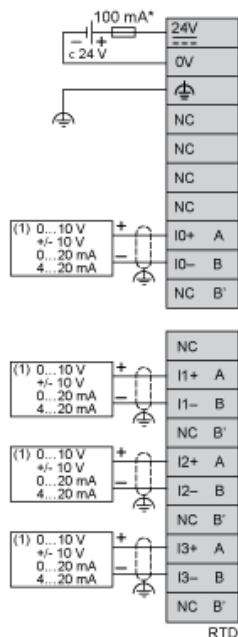

- (\*) Type T fuse
- (1) Current/Voltage analog output device

Wiring Diagram (Thermocouple input type)

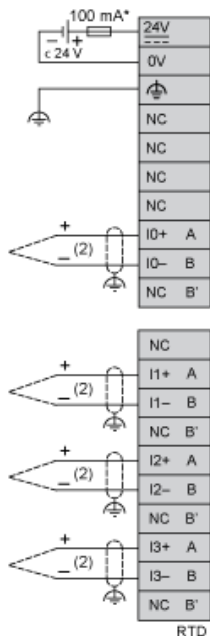

- (\*) Type T fuse
- (2) Thermocouple



## Wiring Diagram (Temperature probe input type)

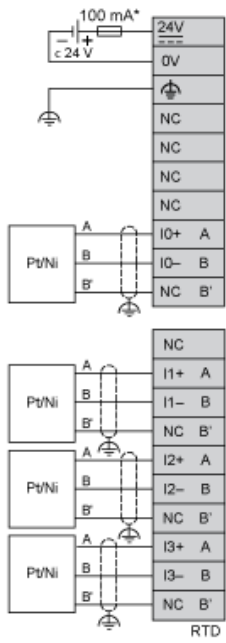

(\*) Type T fuse