



## Main

Product or component type	Passive filter
Product specific application	Reduction of current harmonics

## Complementary

Range compatibility	Altivar 61 Altivar 71
[Us] rated supply voltage	400 V (+/- 10 %)
Power supply frequency	50 Hz (tolerance: +/- 2 %)
Quantity per drive	1 filter per drive for variable speed drive ATV71W motor : 7.5 kW / 10 hp 1 filter per drive for variable speed drive ATV71P motor : 7.5 kW / 10 hp 1 filter per drive for variable speed drive ATV71H motor : 7.5 kW / 10 hp 1 filter per drive for variable speed drive ATV61H motor : 7.5 kW / 10 hp 1 filter per drive for variable speed drive ATV61W motor : 7.5 kW / 10 hp
[In] rated current	15 A for output 14 A for input
Network number of phases	3 phases
THDI	16 % for variable speed drive ATV71W motor : 7.5 kW / 10 hp 16 % for variable speed drive ATV71P motor : 7.5 kW / 10 hp 16 % for variable speed drive ATV71H motor : 7.5 kW / 10 hp 16 % for variable speed drive ATV61H motor : 7.5 kW / 10 hp 10 % for variable speed drive ATV61W motor : 7.5 kW / 10 hp
Max current	1.5 x nominal current (duration = 60 s)
Efficiency	<= 98 %
Thermal losses	118 W
Cos phi	0.99 at 100 % of line current 0.85 at 75 % of line current 1 at 150 % of line current
Electrical connection	A, B terminal, connection capacity: 2.5 mm <sup>2</sup> X1-1...X2-3 terminal, connection capacity: 0.5...10 mm <sup>2</sup>
Electrical insulation class	Class F
Product weight	16.3 kg

## Environment

IP degree of protection	IP55 (enclosure mounting) IP20
Vibration resistance	0.7 gn (f = 13.2...150 Hz) conforming to EN 60068-2-6 2 mm peak to peak (f = 5...13.2 Hz) conforming to EN 60068-2-6
Relative humidity	5...85 % without condensation
Ambient air temperature for operation	5...45 °C without current derating > 45...60 °C with current derating 3 % per °C
Ambient air temperature for storage	> -25...65 °C during transport > -25...55 °C storage in original packaging

---

Operating altitude	> 1000...4000 m with current derating 5 % per 1000 m <= 1000 m without current derating
Standards	EN/IEC 61000-3-2 EN/IEC 61000-3-12 EN/IEC 61000-3-4 EN/IEC 61000-2-2 EN/IEC 61000-2-4 G5/4 engineering recommendation

---

Dimensions

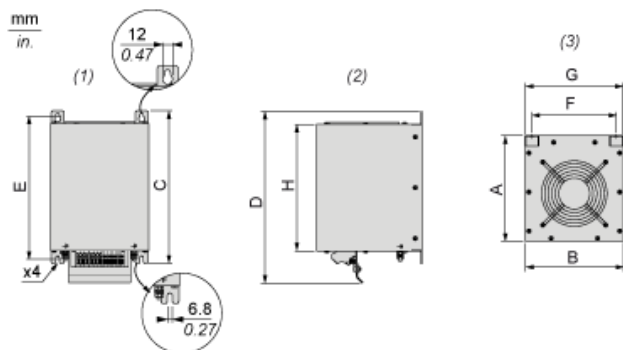

- (1) Front view
- (2) Right side view
- (3) Top view

Dimensions in mm

A	B	C	D	E	F	G	H
205.5	190	295	332.11	276	163	188	246

Dimensions in in.

A	B	C	D	E	F	G	H
8.09	7.48	11.61	13.07	10.87	6.42	7.40	9.69

---

Mounting Recommendations

---

Vertical Mounting Only

mm  
in.

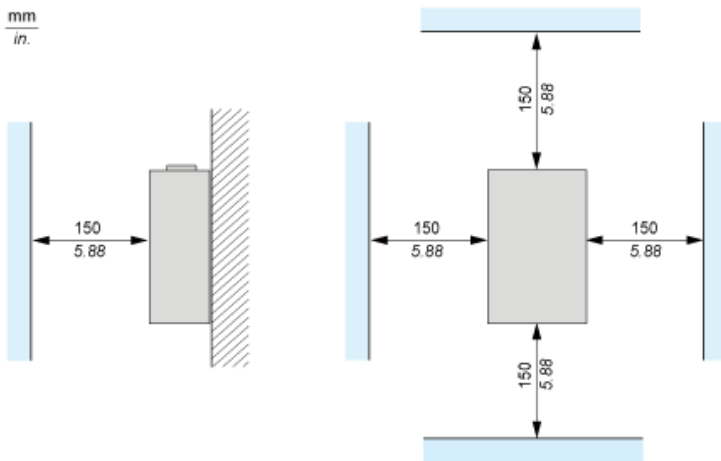

Recommended Schema

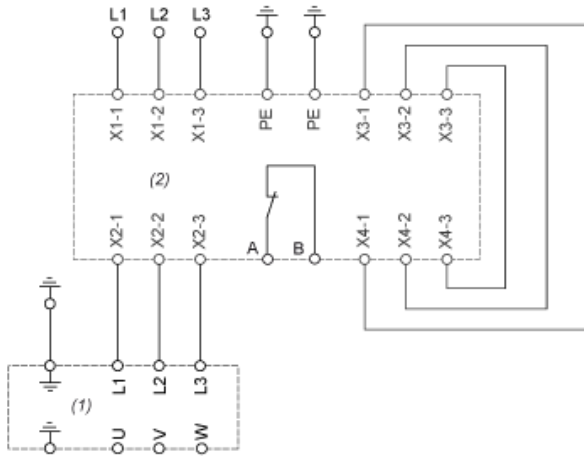

- (1) Drive
- (2) Filter