

# SSL-2J04-G02ME

Plug connectors and cables

ACCESSORIES

**SICK**  
Sensor Intelligence.

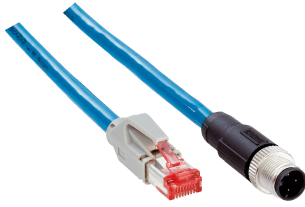

### Ordering information

Type	Part no.
SSL-2J04-G02ME	6034414

Other models and accessories → [www.sick.com/Plug\\_connectors\\_and\\_cables](http://www.sick.com/Plug_connectors_and_cables)

### Detailed technical data

#### Technical specifications

<b>Accessory group</b>	Plug connectors and cables
<b>Accessory family</b>	Connection cables with male and male connector
<b>Connection type head A</b>	Male connector, M12, 4-pin, straight, D-coded
<b>Connection type head B</b>	Male connector, RJ45, 8-pin, straight
<b>Cable</b>	2 m, 4-wire, AWG26, CAT5 (100 Mbit/s), PUR, halogen-free
<b>Jacket material</b>	PUR, halogen-free
<b>Jacket color</b>	Green
<b>Cable diameter</b>	6.4 mm
<b>Conductor cross-section</b>	0.14 mm <sup>2</sup>
<b>Shielding</b>	Shielded
<b>Bending radius</b>	
Flexible use	> 8 x cable diameter
Stationary position	> 4 x cable diameter
<b>Reference voltage</b>	≤ 60 V
<b>Current loading</b>	4 A
<b>Signal type</b>	Ethernet
<b>Special feature</b>	Twisted pair
<b>Enclosure rating</b>	IP67 (M12), IP20 (RJ45) <sup>1)</sup>
<b>Ambient operating temperature</b>	
Flexible use	-20 °C ... +80 °C
Stationary position	-40 °C ... +80 °C
Head	-25 °C ... +90 °C

<sup>1)</sup> M12.

#### Classifications

<b>ECl@ss 5.0</b>	19030312
<b>ECl@ss 5.1.4</b>	19030312
<b>ECl@ss 6.0</b>	27060304
<b>ECl@ss 6.2</b>	27060304
<b>ECl@ss 7.0</b>	27060304
<b>ECl@ss 8.0</b>	27060304
<b>ECl@ss 8.1</b>	27060304

<b>ECI@ss 9.0</b>	27060304
<b>ETIM 5.0</b>	EC000830
<b>ETIM 6.0</b>	EC000830
<b>UNSPSC 16.0901</b>	26121604

Dimensional drawing (Dimensions in mm (inch))

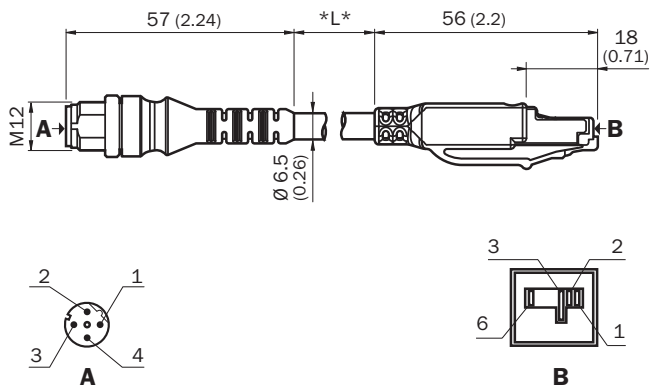

## SICK AT A GLANCE

SICK is one of the leading manufacturers of intelligent sensors and sensor solutions for industrial applications. A unique range of products and services creates the perfect basis for controlling processes securely and efficiently, protecting individuals from accidents and preventing damage to the environment.

We have extensive experience in a wide range of industries and understand their processes and requirements. With intelligent sensors, we can deliver exactly what our customers need. In application centers in Europe, Asia and North America, system solutions are tested and optimized in accordance with customer specifications. All this makes us a reliable supplier and development partner.

Comprehensive services complete our offering: SICK LifeTime Services provide support throughout the machine life cycle and ensure safety and productivity.

For us, that is “Sensor Intelligence.”

## WORLDWIDE PRESENCE:

Contacts and other locations –[www.sick.com](http://www.sick.com)