



# UE48-20S2D2

## UE48-20S

SAFETY RELAYS

**SICK**  
Sensor Intelligence.



Illustration may differ



### Ordering information

Type	Part no.
UE48-20S2D2	6024915

Other models and accessories → [www.sick.com/UE48-20S](http://www.sick.com/UE48-20S)

### Detailed technical data

#### Safety-related parameters

<b>Safety integrity level</b>	SIL3 (IEC 61508) SILCL3 (EN 62061)
<b>Category</b>	Category 4 (EN ISO 13849)
<b>Performance level</b>	PL e (EN ISO 13849)
<b>B<sub>10d</sub> parameter</b>	1.26 x 10 <sup>6</sup> switching cycles (AC-15, 230 V, I = 1.5 A) 5.9 x 10 <sup>6</sup> switching cycles (AC-15, 230 V, I = 0.75 A) 4.35 x 10 <sup>5</sup> switching cycles (DC-13, 24 V, I = 2.5 A) 1 x 10 <sup>7</sup> switching cycles (DC-13, 24 V, I = 0.63 A)
<b>PFH<sub>D</sub> (mean probability of a dangerous failure per hour)</b>	3.0 x 10 <sup>-8</sup> (EN ISO 13849)
<b>T<sub>M</sub> (mission time)</b>	20 years (EN ISO 13849)
<b>Stop category</b>	0 (EN 60204-1)

#### Interfaces

<b>Connection type</b>	Fixed screw terminals
<b>Conductor cross-section</b>	
Single wire (2x, same cross-section)	0.14 mm <sup>2</sup> ... 0.75 mm <sup>2</sup>
Fine wire with ferrules (2x, same cross-section)	0.2 mm <sup>2</sup> ... 0.5 mm <sup>2</sup>
Fine wire with ferrules (1x)	0.25 mm <sup>2</sup> ... 2.5 mm <sup>2</sup>

#### Electrical data

##### Operating data

<b>Voltage supply</b>	A1, A2
Output circuit > 25 V AC / 60 V DC	PELV
Output circuit ≤ 25 V AC / 60 V DC	PELV or SELV

<sup>1)</sup> In DC operation, within the limits of V<sub>S</sub>.

<b>Supply voltage <math>V_s</math></b>	A1, A2 24 V AC/DC (20.4 V AC/DC ... 26.4 V AC/DC)
<b>Residual ripple</b>	$\leq 2.4 V_{pp}^{1)}$
<b>Power consumption</b>	( $\leq 4.6$ VA (AC)) ( $\leq 2.1$ W (DC))
<b>Overvoltage category</b>	II
<b>Rated insulation voltage <math>U_i</math></b>	300 V AC
<b>Rated impulse withstand voltage <math>U_{imp}</math></b>	4 kV
<b>Test voltage</b>	2 kV (50 Hz) (EN 60439-1)

<sup>1)</sup> In DC operation, within the limits of  $V_s$ .

Control voltage: S11, S21, S33

<b>Control voltage</b>	22 V DC ( $\geq 17.4$ V DC)
<b>Control current</b>	40 mA ... 100 mA
<b>Short-circuit current</b>	$\leq 300$ mA, between S33 / S11 and S21
<b>Short-circuit protection</b>	Electronic fuse
<b>Galvanized decoupling</b>	- (between A1, A2 and S11, S21, S33)

Input circuits: S12, S22, S31, S34, S35

<b>Input voltage</b>	HIGH	17.4 V DC ... 26.4 V DC
	LOW	-3 V DC ... 5 V DC
<b>Input current</b>	S12, S22, S31	$\leq 100$ mA
	S34, S35	$\leq 50$ mA
<b>Reset time</b>	Manual	$\leq 40$ ms
	Automatic	$\leq 80$ ms
<b>Activation time of reset button</b>		$\geq 50$ ms
<b>Test pulse width</b>		$\leq 1,000$ $\mu$ s
<b>Test pulse rate</b>		$\leq 10$ Hz
<b>Cable resistance</b>		$\leq 35$ $\Omega$

Electrical output circuits: 13/14, 23/24, 31/32, 33/34

<b>Response time</b>	$\leq 25$ ms <sup>1)</sup>	
<b>Number of enable current (N/O) contacts</b>	2, relevant for safety	
<b>Number of signalling current (N/C) contacts</b>	1, not safety-relevant	
<b>Contact type</b>	Positively driven	
<b>Contact material</b>	Silver alloy, gold flashed	
<b>Switching voltage</b>	Enable current contact	10 V AC ... 230 V AC / 10 V DC ... 300 V DC
	Signalling current contact	10 V AC, 10 V DC ... 230 V AC, 300 V DC
<b>Switching current</b>		

<sup>1)</sup> K1/K2.

Enable current contact	10 mA ... 6 A
Signalling current contact	10 mA ... 6 A
Total current	≤ 12 A
<b>Usage category</b>	AC-15/DC-13 (EN 60947-5-1)
<b>Rated operating current (voltage)</b>	4 A (230 V AC) 360 switching cycles/h 3 A (230 V AC) 3600 switching cycles/h 4 A (24 V DC) 360 switching cycles/h 2.5 A (24 V DC) 3600 switching cycles/h
<b>Switching frequency</b>	≤ 3600/h
<b>Mechanical life (relay contacts)</b>	1 x 10 <sup>7</sup> switching cycles
<b>Electrical life (relay contacts)</b>	2 x 10 <sup>6</sup> switching cycles

<sup>1)</sup> K1/K2.

### Mechanical data

<b>Dimensions (W x H x D)</b>	22.5 mm x 114 mm x 96.5 mm
<b>Weight</b>	0.21 kg

### Ambient data

<b>Enclosure rating</b>	Terminals	IP 20 (EN 60529)
	Housing	IP 40 (EN 60529)
<b>Interference emission</b>		EN 61000-6-4
<b>Interference resistance</b>		EN 61000-6-2
<b>Vibration resistance</b>		10 Hz ... 55 Hz (EN 60068-2-6)
	Amplitude	0.35 mm
<b>Shock resistance</b>		30 g, 11 ms (EN 60068-2-27)

Dimensional drawing (Dimensions in mm (inch))

Safety relay

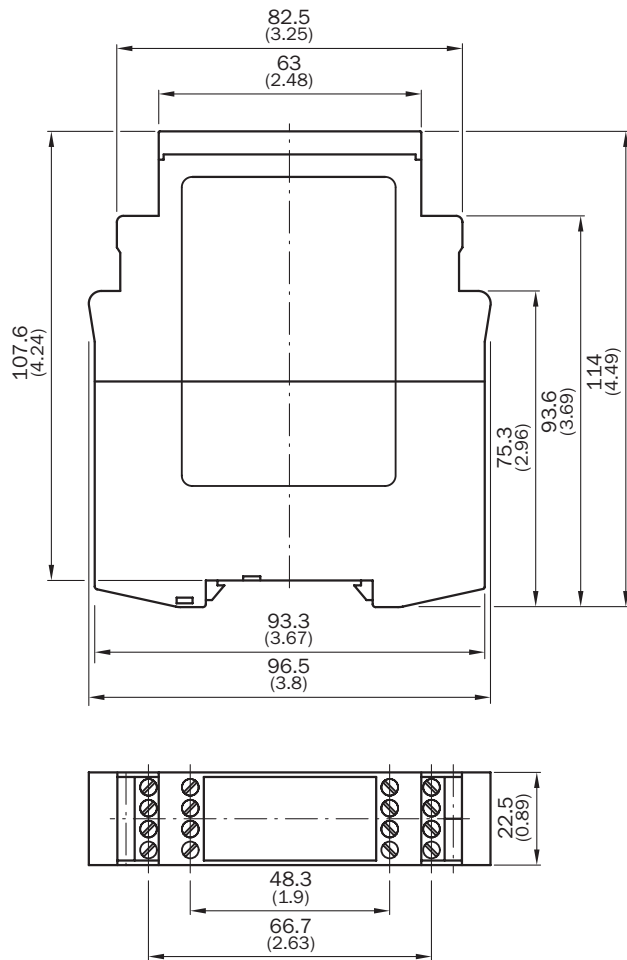

Connection diagram

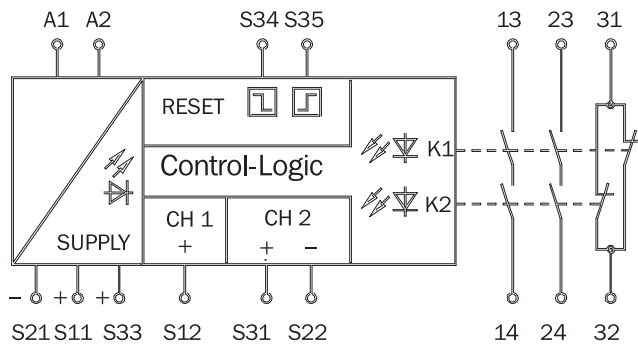

## SICK AT A GLANCE

SICK is one of the leading manufacturers of intelligent sensors and sensor solutions for industrial applications. A unique range of products and services creates the perfect basis for controlling processes securely and efficiently, protecting individuals from accidents and preventing damage to the environment.

We have extensive experience in a wide range of industries and understand their processes and requirements. With intelligent sensors, we can deliver exactly what our customers need. In application centers in Europe, Asia and North America, system solutions are tested and optimized in accordance with customer specifications. All this makes us a reliable supplier and development partner.

Comprehensive services complete our offering: SICK LifeTime Services provide support throughout the machine life cycle and ensure safety and productivity.

For us, that is “Sensor Intelligence.”

## WORLDWIDE PRESENCE:

Contacts and other locations –[www.sick.com](http://www.sick.com)