

accessory for VL160X, VL160, VL250, kit f. leading auxiliary switches  
2 co contacts, from on to off 1.5 meter connecting cable

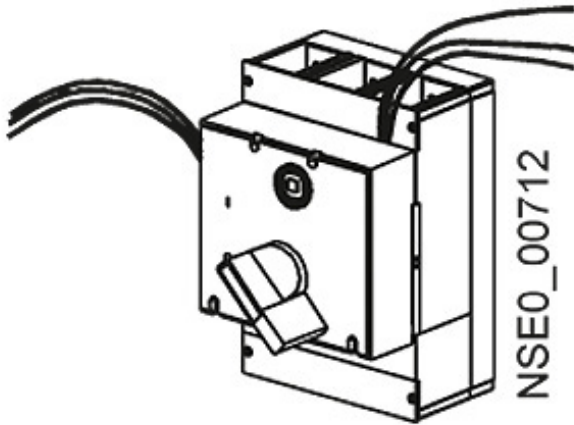

**Model**

Product brand name SENTRON

**Accessories**

accessories Accessories for...VL160, VL250  
Net weight 0.19 kg

<b>General Product Approval</b>	<b>EMC</b>	<b>Test Certificates</b>	<b>Shipping Approval</b>
---------------------------------	------------	--------------------------	--------------------------

[Miscellaneous](#)



[Special Test Certificate](#)



<b>Shipping Approval</b>	<b>other</b>
--------------------------	--------------



[Miscellaneous](#)

[Environmental Confirmations](#)

[Confirmation](#)

## Further information

### **Information- and Downloadcenter (Catalogs, Brochures,...)**

<http://www.siemens.com/lowvoltage/catalogs>

### **Industry Mall (Online ordering system)**

<https://mall.industry.siemens.com/mall/en/en/Catalog/product?mlfb=3VL9300-3AW10>

### **Service&Support (Manuals, Certificates, Characteristics, FAQs,...)**

<https://support.industry.siemens.com/cs/ww/en/ps/3VL9300-3AW10>

### **Image database (product images, 2D dimension drawings, 3D models, device circuit diagrams, ...)**

[http://www.automation.siemens.com/bilddb/cax\\_en.aspx?mlfb=3VL9300-3AW10](http://www.automation.siemens.com/bilddb/cax_en.aspx?mlfb=3VL9300-3AW10)

### **CAX-Online-Generator**

<http://www.siemens.com/cax>

### **Tender specifications**

<http://www.siemens.com/specifications>