

Voltage- and Frequency-Relay UFR1001E

Grid- and Plant Protection according to VDE-AR-N 4105, with integrated Vector-Shift-Relay

UFR1001E



Certificate Grid- and Plant Protection acc. to VDE-AR-N 4105



Certificate medium voltage acc. to bdew-directive

The UFR1001E monitors voltage and frequency in plants for own generation of electricity. It fulfills the requirements of VDE-AR-N 4105 for generators connected to the low-voltage and the directive bdew 2008 for the medium-voltage distribution network. Monitoring of feedback contacts can be suppressed during shutoff and synchronisation.

The UFR1001E is a dual-channel device and thus one-fault-proof. Input-circuit, A/D-converter, processor and output-relay are doubly present. The processors control each other. The function of the output-relays and of the connected switches can be monitored with feed-back contacts. At an alarm the device switches off and the reason is displayed with LEDs and signaled with transistor-outputs.

The limits are pre-set according to VDE-AR-N 4105. They can be changed if required and be protected with a code and/or a seal.

An alarm-counter stores the last 100 alarms with reason and elapsed time. In addition the time the UFR1001E has interrupted the plant is recorded. All values can be read-out with the integrated display and give the operator valuable information about the availability of the plant.

With a test-button the function of the connected switches can be tested and their switching-time can be measured. The simulation displays the complete switching-time of device plus connected switches.

The standby input allows a remote shutoff e.g. with a RCR. It can also be used to switch to an energy saving mode by a timer or a twilight switch.

- Monitoring of under- and overvoltage 15-520 V
- Measuring phase-neutral or phase-phase
- Monitoring of under- and overfrequency 45-65 Hz
- Monitoring of quality of voltage (10-minutes-average)
- Monitoring of vector shift 2...20 °
- One-fault-proof with monitoring of connected switches (defeatable), 2 automatic restarts at error
- Passive detection of insular grid acc. to ch. 6.5.3 and app. D2
- Support of synchronisation of generators
- Selftest
- Switching delay adjustable 0,05 ... 130 s
- Switching-back-delay adjustable 0 ... 999 s
- Switching-back-delay at alarms <3 s: 5 s
- Preset values acc. to VDE-AR-N 4105 and bdew-directive
- Alarm-counter for 100 alarms with value, reason and elapsed time
- Recording of elapsed time of alarms
- Input for standby with counter and recording of time
- Test-button and simulation with measuring of switching-times
- LEDs for alarms. Allocation of values and states of relays
- Sealing. All values can be read-out when sealed
- Easy installation and programming with 6 pre-set programs
- Outputs for reporting of alarms to superior control
- Supply-voltage AC/DC 24-270 V
- Housing for DIN-rail-mount, 70 mm wide, mounting height 66 mm

Medium voltage:

- 2 x 2 alarms for voltage and frequency (U>>, U>, U<, U<<, F>>, F>, F<, F<<)
- Individual adjustment of switching-delay for every alarm

Order-Number:

S222296

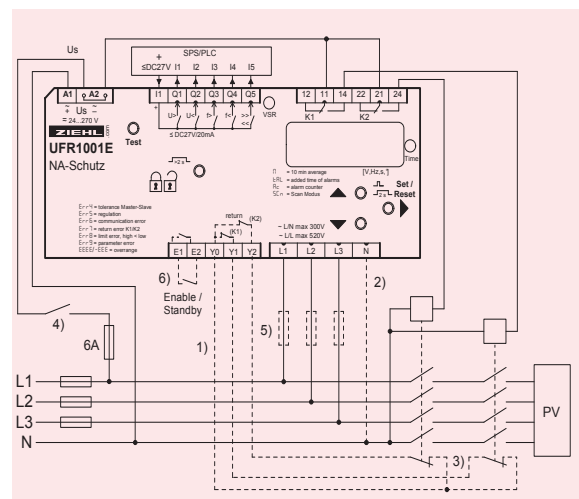

Technical Data UFR1001E

Power supply	Rated supply voltage U_s	AC/DC 24-270 V, 0/45...65 Hz, <5VA DC: 20,4...297 V, AC: 20,4...297 V
Relay output		2 change-over contacts type 2, see "general technical informations"
Voltage	Measurement voltage phase-phase	AC 15...530 V (< 5 V display: 0)
	Setting range phase-phase	AC 15...520 V
	Measuring voltage phase-neutral	AC 10...310 V (< 5 V display: 0)
	Setting range phase-neutral	AC 15...300 V
	Measurement method	true RMS
	Hysteresis	adjustable 1,0...99,9 V
	Measurement accuracy (with neutral)	$\pm 0,6\%$ of measured value
	Measurement accuracy (without neutral)	$\pm 0,8\%$ of measured value
	Accuracy of display	>100V: -1 digit (resolution 1 V) <100V: -1 digit (resolution 0,1 V)
	Measurement functions	3-phase with / without neutral
Switching-delay (dAL)	adjustable 0,05 (± 15 ms)...130,0 s	
Switching-back-delay (doF)	adjustable 0 (approx. 200 ms)...1000 s	
Frequency	Measurement range	40...70 Hz
	Setting range	45,00...65,00 Hz
	Hysteresis	0,05...10,00 Hz
	Measurement accuracy	$\pm 0,04$ Hz ± 1 digit
	Switching delay (dAL)	adjustable 0,05 (± 15 ms)...130,0 s
	Switching-back-delay (doF)	adjustable 0 (>200 ms)...999 s
Vector-Shift	Measurement range	0...45,0°
	Setting range	2,0...20,0°
	Switching-delay (dAL)	< 50 ms
	Switching-back-delay (doF)	adjustable 3...240 s
	Delay at U_s on	adjustable 2...20 s
Digital outputs insulated	Voltage I1	DC 4,5...27 V
	Current Q1...Q5	max. 20 mA / output
Input Feed-back-contacts	Voltage Y0...Y1/2	DC 15...35 V
	Switching time connected switches	adjustable 0,5...99,0 s
Test Conditions		EN 60255
	Rated impulse voltage	4000 V
	Overvoltage category	III
	Rated Insulation voltage	2
	Contamination level	300 V
	Isolation material group	II
	ON-period	100 %
	Rated ambient temp. range	-20 °C...+55 °C EN 60 068-2-2 dry heat
	Interference resistance	EN 61 000-6-2
Interference transmission	EN 61 000-6-4	
Housing	Design	V6
	Dimensions (h x w x d)	90 x 105 x 69 mm, mounting height 66 mm
	Protection housing	IP30
	Protection terminals	IP20
	Attachment	DIN-rail 35 mm according to EN 60 715 or screws M4
	Weight	ca. 250 g