

KA 072F/00/a6/01.04
017122-0000

nivector FTC 968

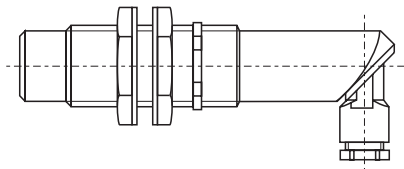

- d** Füllstandgrenzscharter
- e** Level Limit Switch
- f** Détecteur de niveau
- es** Detector de nivel
- i** Interruttore di livello
- nl** Niveauschakelaar

Endress + Hauser

The Power of Know How



d Inhalt

Sicherheitshinweise	4
Verwendung, Meßeinrichtung	6
Einbau	7
Anschluß	9
Einstellung	12
Test	14
Abgleich (falls erforderlich)	15
Technische Daten	18
Ergänzende Dokumentation	20

e Contents

Notes on safety	4
Application, Measuring system	6
Installation	7
Connection	9
Set-up	12
Test	14
Calibration (if necessary)	15
Technical data	18
Supplementary documentation	20

f Sommaire

Conseils de sécurité	4
Utilisation, Ensemble de détection de niveau	6
Montage	7
Raccordement	9
Réglage	12
Test	14
Etalonnage (si nécessaire)	15
Caractéristiques techniques	18
Documentation complémentaire	20

es Índice

Notas sobre seguridad	5
Aplicación, Sistema de medida	6
Montaje	7
Conexión	9
Ajuste	12
Comprobación	14
Calibración (si se requiere)	15
Datos técnicos	18
Documentación suplementaria	20

i Índice

Nota sulla sicurezza	5
Applicazione, Dispositivo di misura	6
Montaggio	7
Collegamento	9
Messa in marcia	12
Test	14
Calibrazione (se necessario)	15
Dati tecnici	18
Documentazione supplementare	20

nl Inhoud

Veiligheidsinstructies	5
Toepassing, Meetopstelling	6
Inbouw	7
Aansluiting	9
Instelling	12
Test	14
Afregeling (indien nodig)	15
Technische gegevens	18
Aanvullende documentatie	20

d Sicherheitshinweise

Der Nivector FTC 968 darf nur als Füllstandgrenzschalter für feinkörnige Schüttgüter in nicht explosionsgefährdeten Bereichen verwendet werden. Bei unsachgemäßem Einsatz können Gefahren von ihm ausgehen.

Das Gerät darf **nur von qualifiziertem und autorisiertem Fachpersonal** unter besonderer Beachtung dieser Betriebsanleitung, der einschlägigen Normen, der gesetzlichen Vorschriften und der Zertifikate (je nach Anwendung) eingebaut, angeschlossen, in Betrieb genommen und gewartet werden.



Achtung!

X = verboten; führt zu fehlerhaftem Betrieb oder Zerstörung.

e Notes on Safety

The Nivector FTC 968 is a level limit switch, designed for use in fine-grained bulk solids in non-hazardous areas.

If used incorrectly it is possible that application-related dangers may arise. The level limit switch Nivector FTC 968 may be installed, connected, commissioned, operated and maintained **by qualified and authorised personnel only**, under strict observance of these operating instructions, any relevant standards, legal requirements, and, where appropriate, the certificate.



Caution!

X = forbidden; leads to incorrect operation or destruction.

f Conseils de sécurité

Le Nivector FTC 968 est un détecteur de niveau pour produits solides en vrac de faible granulométrie, en zones non explosibles. Il peut être source de danger en cas d'utilisation non conforme aux prescriptions. L'appareil ne doit être installé, raccordé, mis en service et maintenu **que par un personnel qualifié et autorisé**, qui tiendra compte des indications contenues dans la présente mise en service, des normes en vigueur et des certificats disponibles (selon l'application)



Attention!

X = interdit; peut provoquer des dysfonctionnements ou la destruction.

es Notas sobre seguridad

El Nivector FTC 968 debe emplearse única y exclusivamente como detector de nivel en zonas sin peligro de explosión. Su empleo inapropiado puede resultar peligroso. El equipo deberá ser montado, conectado, instalado y mantenido **única y exclusivamente por personal cualificado y autorizado**, bajo rigurosa observación de las presentes instrucciones de servicio, de las normativas y legislaciones vigentes, así como de los certificados (dependiendo de la aplicación).

i Note sulla sicurezza

Il Nivector FTC 968 può essere utilizzato come interruttore di livello solo in aree sicure. Un'installazione non corretta può determinare pericolo. Lo strumento può essere montato **solamente da personale qualificato ed autorizzato**. La messa in esercizio e la manutenzione devono rispettare le indicazioni di collegamento, le norme e i certificati di seguito riportati.

nl Veiligheidsinstructies

Gebruik de Nivector FTC 968 alléén als niveauschakelaar voor poeders en fijne granulaten in niet explosiegevaarlijke gebieden. Indien niet correct gebruikt kunnen gevaarlijke situaties ontstaan. Het instrument **alleen door gekwalificeerd en geautoriseerd personeel** laten inbouwen, aansluiten, in bedrijf nemen en onderhouden. Neem de instructies in deze Inbedrijfstellingsvoorschriften, de desbetreffende normen, de wettelijke voorschriften en eventuele certificaten in acht.



¡Atención!

X = Prohibido; peligro de mal funcionamiento o de destrucción.



Attenzione!

X = Vietato; pericolo di malfunzionamento o di distruzione.



Opgelet!

X = verboden; leidt tot foutieve werking of storing.

- d** Verwendung,
Meßeinrichtung
- e** Application,
Measuring system
- f** Utilisation,
Ensemble de détection
de niveau
- es** Aplicación,
Sistema de medida
- i** Applicazione,
Dispositivo di misura
- nl** Toepassing,
meetopstelling

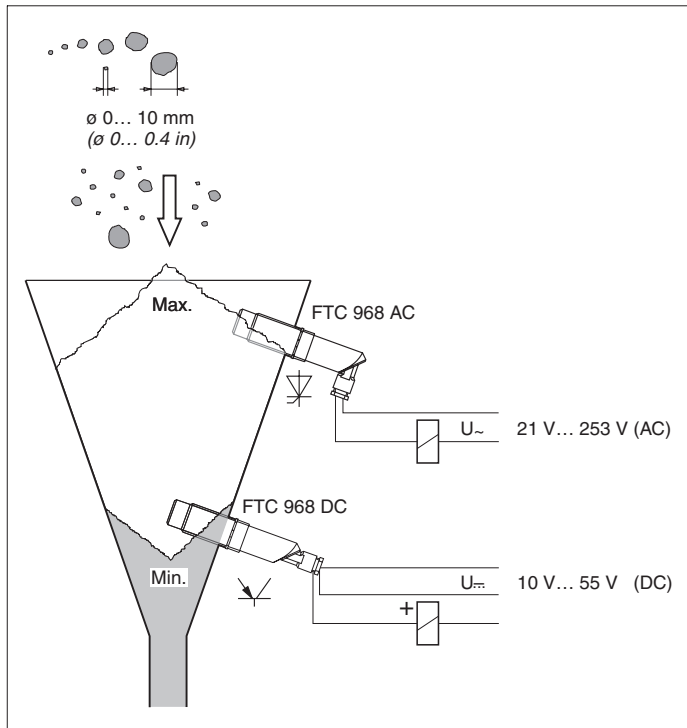

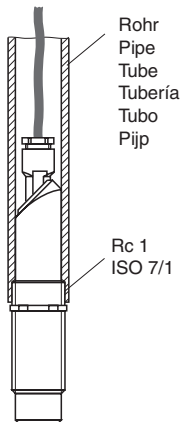
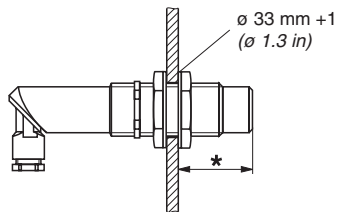
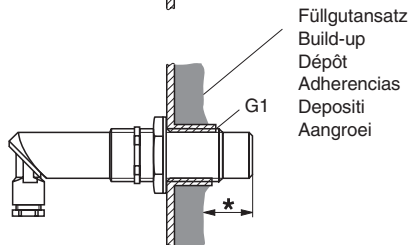
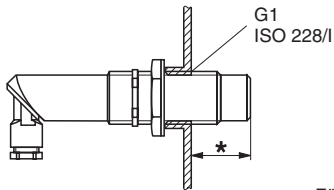

* = min. 20 mm
(min. 0.8 in)

d Einbau
e Mounting
f Montage
es Montaje
i Montaggio
nl Inbouw

d Direkt einbauen
e Install directly
f Monter directement
es Instalar directamente
i Installazione diretta
nl Direct installeren

($\epsilon_r > 2,0$)

- d** Mit Protector einbauen
- e** Install with Protector
- f** Monter avec Protector
- es** Instalar con Protector
- i** Installazione con il Protector
- nl** Installeren met Protector

($\epsilon_r > 1,6$)

- d** Mediumberührendes Teil des Einbauadapters "Protector": FDA gelistetes Material *1
- e** Wettet parts of the build-in adapter "Protector": FDA listed material *1
- f** Pièce de l'adaptateur de montage "Protector" en contact avec le produit : matériau listé FDA *1
- es** Partes húmedas del adaptador "Protector": listado de material FDA *1
- i** Parti a contatto con il prodotto dell'adattatore "Protector": materiale listato FDA *1
- nl** Proces contactdeel van de inbouwadapter "Protector": FDA aangegeven materiaal *1

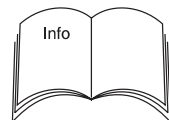
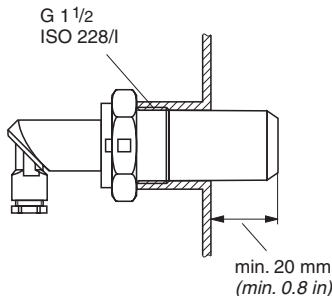

E+H 013343-1000

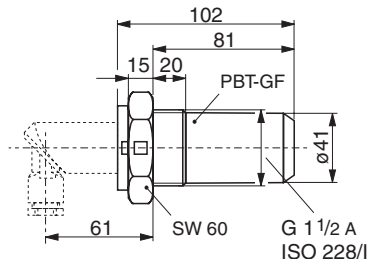

Protector
E+H 917255-1000

*1
21 CFR Part 177.1660

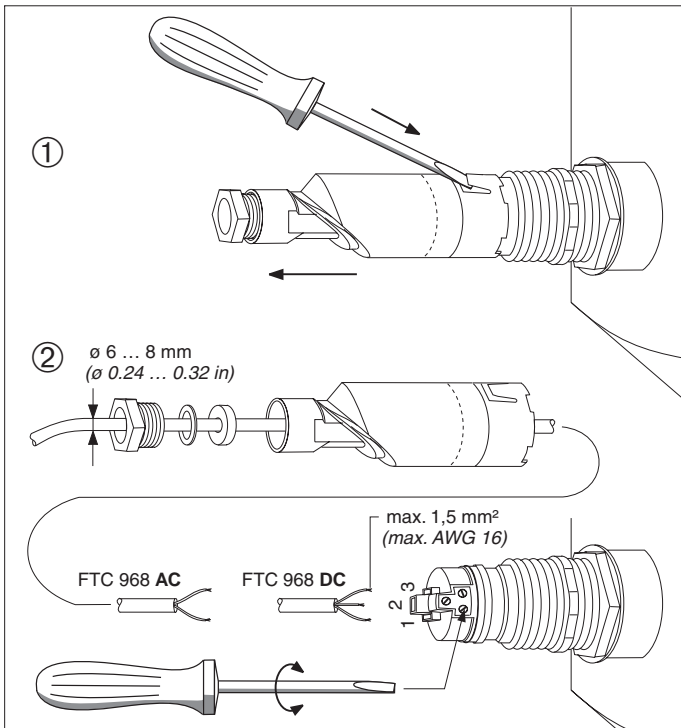

- d** Anschluß
- e** Connection
- f** Raccordement
- es** Conexión
- i** Collegamento
- nl** Aansluiting

- ①
- d** Anschlußraum öffnen
- e** Open the terminal chamber
- f** Ouvrir le compartiment de raccordement
- es** Abrir la caja de conexiones
- i** Aprire la camera terminale
- nl** Aansluitruimte openen

- ②
- d** Kabel einführen
- e** Insert cable
- f** Insérer le câble
- es** Insertar cable
- i** Inserire il cavo
- nl** Kabel invoeren

③ AC

- d** FTC 968 AC anschließen
(Zweileiter-
Wechselstromanschluß)
- e** Connect FTC 968 AC
(Two-wire AC connection)
- f** Raccorder le FTC 968 AC
(Raccordement 2 fils
pour courant alternatif)
- es** Conectar FTC 968 AC
(Conexión a corriente alterna
a dos hilos)
- i** Connettere FTC 968 AC
(Collegamento bifilare
con corrente alternata)
- nl** Sluit de FTC 968 AC aan
(2-draads wisselspannings-
aansluiting)

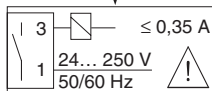
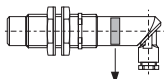

③ AC

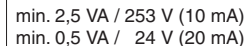
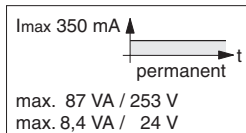
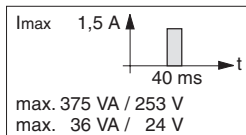
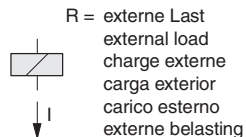
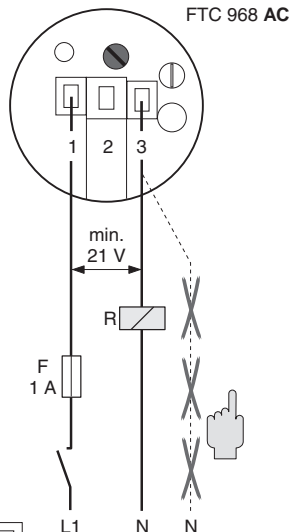

③ DC

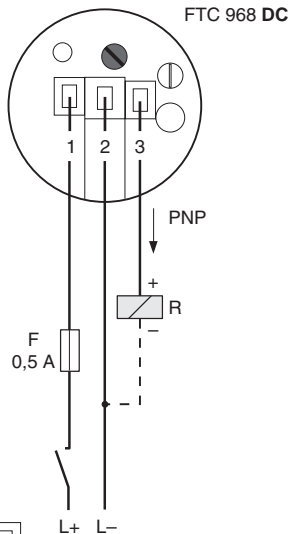

R = externe Last
external load
charge externe
carga exterior
carico esterno
externe belasting

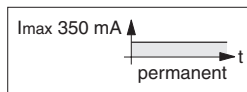
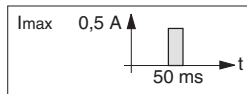

U_{max} 55 V
 C_{max} 0,5 μ F / 55 V
 C_{max} 1,0 μ F / 24 V

③ DC

- d** FTC 968 DC anschließen
(Dreileiter-
Gleichstromanschluß)
- e** Connect FTC 968 DC
(Three-wire DC connection)
- f** Raccorder le FTC 968 DC
(Raccordement 3 fils
pour courant continu)
- es** Conectar FTC 968 DC
(Tres hilos, alimentación CC)
- i** Connettere FTC 968 DC
(Connessione DC a tre fili)
- nl** Sluit de FTC 968 DC aan
(3-draads PNP)

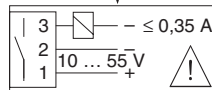
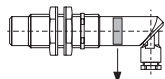

- d** Einstellung
- e** Set-up
- f** Réglage
- es** Ajuste
- i** Set-up
- nl** Instelling

- ①
- d** Sicherheitschaltung wählen
- e** Setting fail-safe mode
- f** Choisir la commutation de sécurité
- es** Ajuste del modo de seguridad
- i** Impostare la modalità di sicurezza
- nl** Kies fail-safe instelling (ruststroomprincipe)

①

Maximum-Sicherheit
 Max. fail-safe mode
 Sécurité maximum
 Modo seguridad máx.
 Modalità di max.
 Max. fail-safe

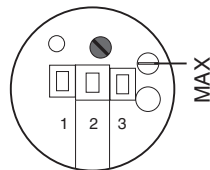
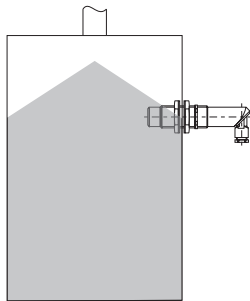

oder / or / ou / o / o / of

Minimum-Sicherheit
 Min. fail-safe mode
 Sécurité minimum
 Modo seguridad mín.
 Modalità di min.
 Min. fail-safe

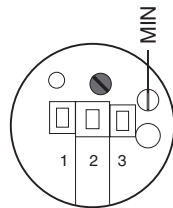
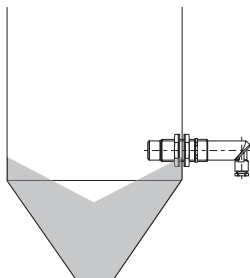

②

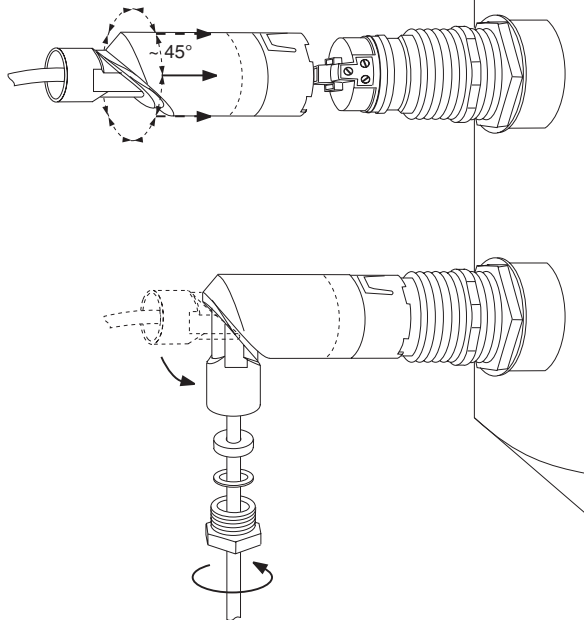

②

- d** Anschlußraum schließen, Kabeleinführung ausrichten und zuschrauben
- e** Close terminal compartment align cable entry and screw tight
- f** Fermer le compartiment de raccordement, orienter l'entrée de câble et visser fermement
- es** Cerrar compartimento terminales, alinear entrada de cables y roscar firmemente
- i** Chiudere il comparto terminale, allineare l'ingresso cavi e avvitare
- nl** Aansluitruimte sluiten, Wartel (naar beneden) richten en dichtdraaien

- d** Test
- e** Test
- f** Test
- es** Comprobación
- i** Test
- nl** Test

- ①
- d** Einschalten
 - e** Switch on
 - f** Mettre sous tension
 - es** Conectar
 - i** Accendere
 - nl** Inschakelen

- ②
- d** Behälter füllen
 - e** Fill silo
 - f** Remplir le réservoir
 - es** Llenar el tanque
 - i** Riempire il serbatoio
 - nl** Vul de silo

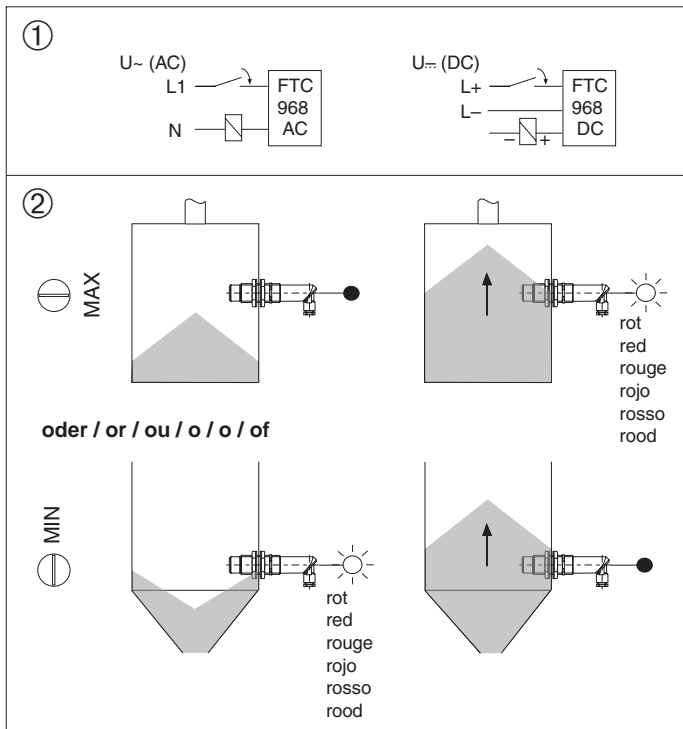

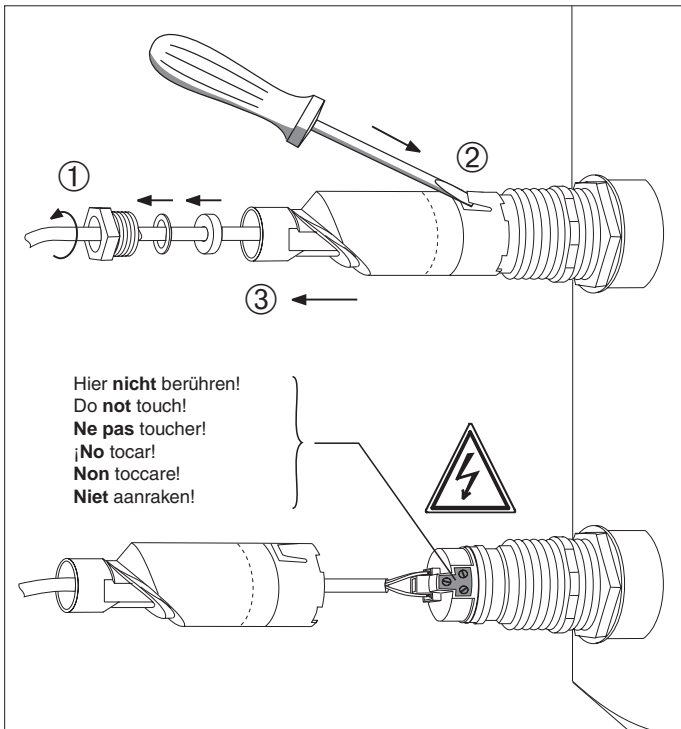

- d Abgleich**
nur, wenn Nivector beim Test **nicht** schaltet
- e Calibrate**
only if Nivector does **not** switch when tested
- f Etalonnage**
seulement si le Nivector **ne** commute **pas** au cours du test
- es Calibrar**
sólo si Nivector **no** conmuta cuando se prueba
- i Calibrazione**
solo se il Nivector **non** commuta durante il test
- nl Afregelen**
alleen indien Nivector bij de test **niet** schakelt

① ② ③

- d** Anschlußraum öffnen
- e** Open the terminal chamber
- f** Ouvrir le compartiment de raccordement
- es** Abrir la caja de conexiones
- i** Aprire la camera terminale
- nl** Aansluitruimte openen

④

d Bis zum Grenzstand füllen

e Fill to limit level

f Remplir jusqu'au seuil

es Llenar hasta el nivel límite

i Riempire fino al livello

nl Tot over het gewenste
niveau vullen



⑤

d Langsam drehen

e Turn slowly

f Tourner lentement

es Girar lentamente

i Ruotare lentamente

nl Langzaam draaien

④

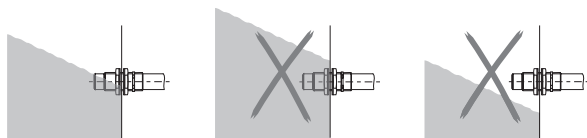

⑤

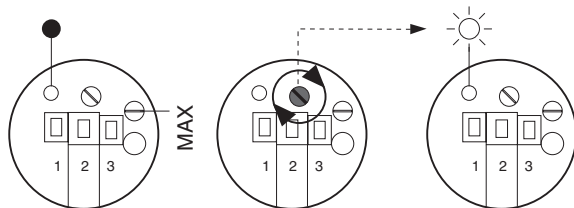

oder / or / ou / o / o / of

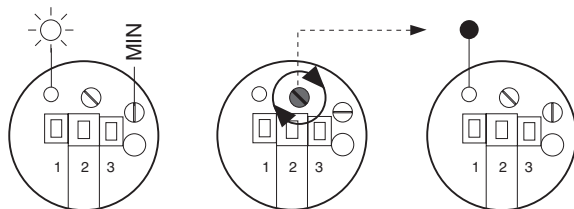

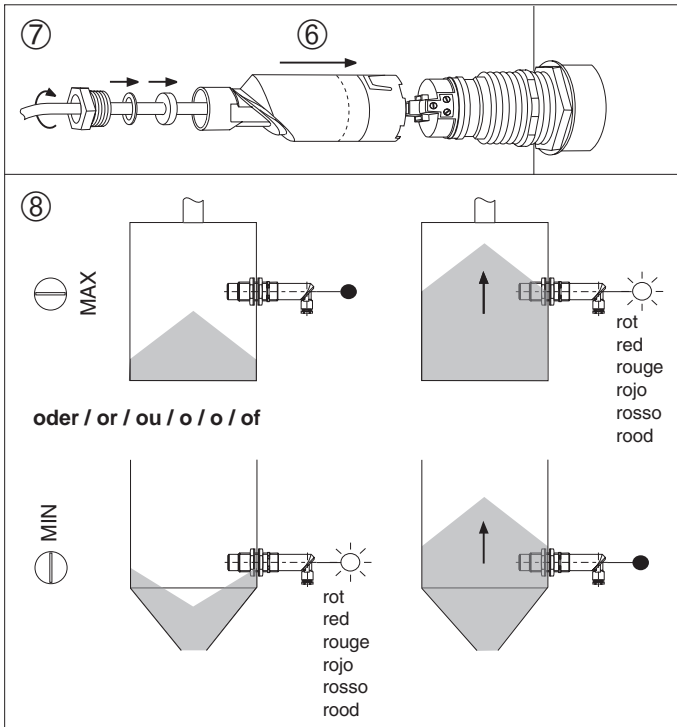

- ⑥ ⑦
- d** Anschlußraum schließen
 - e** Close terminal compartment
 - f** Fermer le compartiment de raccordement
 - es** Cerrar compartimento terminales
 - i** Chiudere il comparto terminale
 - nl** Aansluitruimte sluiten

- ⑧
- d** Testen
 - e** Test
 - f** Test
 - es** Prueba
 - i** Test
 - nl** Testen

- d** Technische Daten
- e** Technical Data
- f** Caractéristiques techniques
- es** Datos técnicos
- i** Dati tecnici
- nl** Technische gegevens

(A)

- d** Abmessungen in mm
- e** Dimensions in mm
- f** Dimensions en mm
- es** Dimensiones en mm
- i** Dimensioni in mm
- nl** Afmetingen in mm

(A)

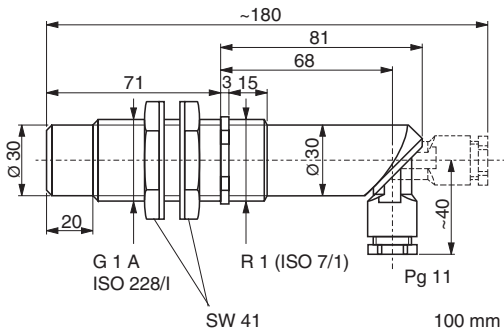







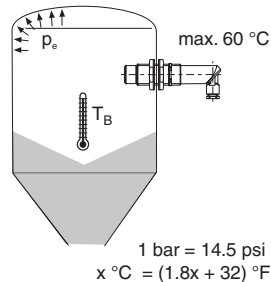
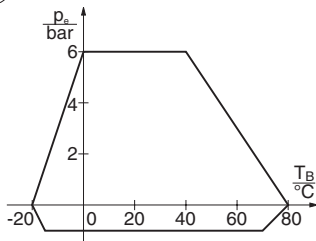

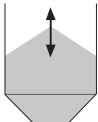

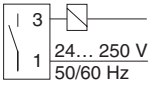
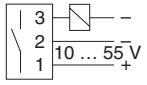
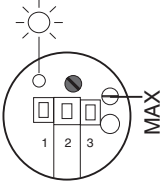
(B)

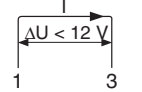
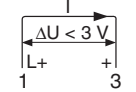
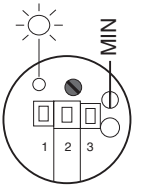
(B)

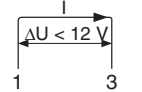
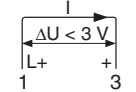
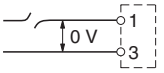
- d** Druck, Temperatur
- e** Pressure, Temperature
- f** Pression, Température
- es** Presión, Temperatura
- i** Pressione, Temperatura
- nl** Druk, Temperatuur

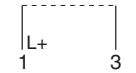

			FTC 968 AC 	FTC 968 DC 
				
				
				

©

- d** Funktion, elektrische Daten
- e** Function, electrical data
- f** Fonction, données électriques
- es** Funcionamiento, datos eléctricos
- i** Funzionamento, dati tecnici
- nl** Functie, elektrische gegevens

d Ergänzende
Dokumentation

e Supplementary
Documentacion

f Documentation
complémentaire

es Documentación
adicional

i Documentazione
supplementare

nl Aanvullende
documentatie

d TI 037F/00/de - Technische Information für den Füllstandgrenzscharter
Nivector FTC 968, FTC 968 Z

e TI 037F/00/en - Technical Information for level limit switch
Nivector FTC 968, FTC 968 Z

f TI 037F/14/fr - Information technique pour le détecteur de niveau
Nivector FTC 968, FTC 968 Z

es TI 037F/23/es - Información técnica sobre el detector de nivel
Nivector FTC 968, FTC 968 Z

i TI 037F/16/it - Informazioni tecniche per l'interruttore di livello
Nivector FTC 968, FTC 968 Z

nl TI 037F/15/nl - Technische Informatie voor de niveauschakelaar
Nivector FTC 968, FTC 968 Z

Endress+Hauser Sales Centers

AT Tel. (01) 8 8056-0, Fax (01) 8 8056-35

BE Tel. (02) 2 48 06 00, Fax (02) 2 48 05 53

CAN Tel. (905) 6 81 92 92, Fax (905) 6 81 94 44

CH Tel. (061) 7 15 75 75, Fax (061) 7 11 16 50

DE Tel. (0 76 21) 9 75 01, Fax (0 76 21) 9 75 55 55

DK Tel. (70) 13 11 32, Fax (70) 13 21 33

ES Tel. (93) 4 80 33 66, Fax (93) 4 73 38 39

FI Tel. (0204) 8 31 60, Fax (0204) 8 31 61

FR Tel. (3 89) 6 96 67 68, Fax (3 89) 6 96 48 02

GB Tel. (0161) 2 865 000, Fax (0161) 9 981 841

HK Tel. 25 28 31 20, Fax 28 65 41 71

IT Tel. (02) 9 21 92-1, Fax (02) 9 21 92-362

JP Tel. (04 22) 5 40 6 13, Fax (04 22) 5 50 2 75

MAL Tel. (03) 7 33 48 48, Fax (03) 7 33 88 00

NO Tel. (0 32) 8 59 8 50, Fax (0 32) 8 59 8 51

NL Tel. (0 35) 6 95 8 6 11, Fax (0 35) 6 95 8 8 25

SE Tel. (08) 5 55 1 16 00, Fax (08) 5 55 1 16 55

SGP Tel. 5 66 8 2 22, Fax 5 66 6 8 4 8

THA Tel. (2) 9 96 7 8 11-20, Fax (2) 9 96 7 8 10

USA Tel. (3 17) 5 35 7 1 38, Fax (3 17) 5 35 8 4 98

ZA Tel. (011) 2 62 8 0 00, Fax (011) 2 62 8 0 6 2

INTERNATIONAL Tel. + Fax: see DE
<http://www.endress.com> 05.01/PT



017122-0000