

MA ELx8xx
13434909



L-force *Controls*

Montageanleitung

Mounting Instructions

Instructions de montage

Instrucciones para el montaje

Istruzioni per il montaggio

Industrial PC

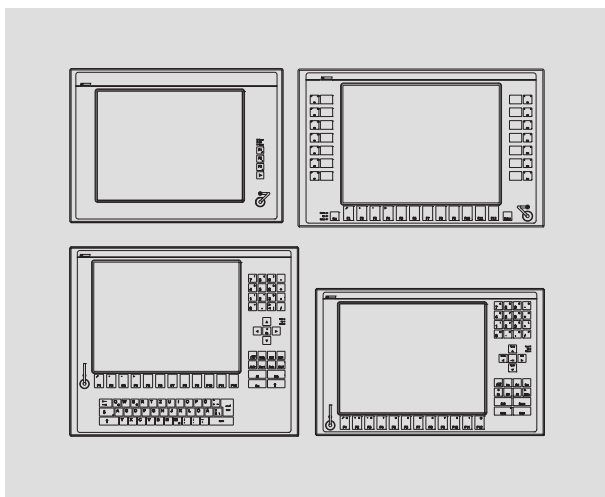

EL 1800 ... EL 9800

Embedded Line Panel PC (EL)

Lenze



Lesen Sie zuerst diese Anleitung, bevor Sie mit den Arbeiten beginnen!
Beachten Sie die enthaltenen Sicherheitshinweise.
Ausführliche Informationen finden Sie in der Betriebsanleitung.



Read these instructions before you start working!
Follow the safety instructions given.
More detailed information can be found in the Operating Instructions.



Veillez lire attentivement cette documentation avant toute action !
Les consignes de sécurité doivent impérativement être respectées.
Pour plus de détails, consulter les instructions de mise en service.



Lea estas instrucciones antes de empezar a trabajar.
Observe las instrucciones de seguridad indicadas.
El manual de instrucciones implica informaciones detalladas.



Prima di iniziare qualsiasi intervento, leggere le presenti istruzioni.
Osservare le note di sicurezza.
Le istruzioni operative contengono informazioni dettagliati.

1	Über diese Dokumentation	4
1.1	Verwendete Hinweise	4
2	Sicherheitshinweise	5
2.1	Allgemeine Sicherheitshinweise	5
2.2	Sicherheitshinweise für die Installation nach UL	6
3	Produktbeschreibung	8
3.1	Lieferumfang	8
3.2	Bedien- und Anzeigeelemente	9
4	Installation	10
4.1	Wichtige Hinweise	10
4.2	Abmessungen	11
4.3	Einbauausschnitt	12
4.4	Montageschritte	13
4.4.1	Panel PC EL 1800(s) / EL 1850(s)	13
4.4.2	Panel PC EL 2800 / EL 2850 / EL 5800 / EL 5820 / EL 5850 / EL 5870 / EL 9800	14
4.5	Elektrische Installation	16

1 Über diese Dokumentation

Verwendete Hinweise

1 Über diese Dokumentation

1.1 Verwendete Hinweise

Um auf Gefahren und wichtige Informationen hinzuweisen, werden in dieser Dokumentation folgende Piktogramme und Signalwörter verwendet:

Sicherheitshinweise

Aufbau der Sicherheitshinweise:





Gefahr!



(kennzeichnet die Art und die Schwere der Gefahr)

Hinweistext

(beschreibt die Gefahr und gibt Hinweise, wie sie vermieden werden kann)

Piktogramm und Signalwort	Bedeutung
 Gefahr!	Gefahr von Personenschäden durch gefährliche elektrische Spannung Hinweis auf eine unmittelbar drohende Gefahr, die den Tod oder schwere Verletzungen zur Folge haben kann, wenn nicht die entsprechenden Maßnahmen getroffen werden.
 Gefahr!	Gefahr von Personenschäden durch eine allgemeine Gefahrenquelle Hinweis auf eine unmittelbar drohende Gefahr, die den Tod oder schwere Verletzungen zur Folge haben kann, wenn nicht die entsprechenden Maßnahmen getroffen werden.
 Stop!	Gefahr von Sachschäden Hinweis auf eine mögliche Gefahr, die Sachschäden zur Folge haben kann, wenn nicht die entsprechenden Maßnahmen getroffen werden.

Anwendungshinweise

Piktogramm und Signalwort	Bedeutung
 Hinweis!	Wichtiger Hinweis für die störungsfreie Funktion
 Tipp!	Nützlicher Tipp für die einfache Handhabung
 Verweis!	Verweis auf andere Dokumentation

2 Sicherheitshinweise

2.1 Allgemeine Sicherheitshinweise

Auch zu Ihrer eigenen Sicherheit



Gefahr!

Wenn Sie die folgenden grundlegenden Sicherheitsmaßnahmen missachten, kann dies zu schweren Personenschäden und Sachschäden führen:

- ▶ Lenze-Antriebs- und Automatisierungskomponenten ...
 - ... ausschließlich bestimmungsgemäß verwenden.
 - ... niemals trotz erkennbarer Schäden in Betrieb nehmen.
 - ... niemals technisch verändern.
 - ... niemals unvollständig montiert in Betrieb nehmen.
 - ... niemals ohne erforderliche Abdeckungen betreiben.
 - ... können während und nach dem Betrieb - ihrer Schutzart entsprechend - spannungsführende, auch bewegliche oder rotierende Teile haben. Oberflächen können heiß sein.
- ▶ Für Lenze-Antriebs- und Automatisierungskomponenten ...
 - ... nur das zugelassene Zubehör verwenden.
 - ... nur Original-Ersatzteile des Herstellers verwenden.
- ▶ Alle Vorgaben der beiliegenden und zugehörigen Dokumentation beachten.

Dies ist Voraussetzung für einen sicheren und störungsfreien Betrieb sowie für das Erreichen der angegebenen Produkteigenschaften.

Die in diesem Dokument dargestellten verfahrenstechnischen Hinweise und Schaltungsausschnitte sind Vorschläge, deren Übertragbarkeit auf die jeweilige Anwendung überprüft werden muss. Für die Eignung der angegebenen Verfahren und Schaltungsvorschläge übernimmt der Hersteller keine Gewähr.
- ▶ Alle Arbeiten mit und an Lenze-Antriebs- und Automatisierungskomponenten darf nur qualifiziertes Fachpersonal ausführen.

Nach IEC 60364 bzw. CENELEC HD 384 sind dies Personen, ...

 - ... die mit Aufstellung, Montage, Inbetriebsetzung und Betrieb des Produkts vertraut sind.
 - ... die über die entsprechenden Qualifikationen für ihre Tätigkeit verfügen.
 - ... die alle am Einsatzort geltenden Unfallverhütungsvorschriften, Richtlinien und Gesetze kennen und anwenden können.

Sicherheitshinweise für die Installation nach UL**Approval**

Underwriter Laboratories (UL), UL508 and CSA C22.2 No. 142-M1987, (UL File Number E236341)

Ratings

- ▶ Input 24 V DC, 65 W
- ▶ Max. Ambient Temperature 40 °C
 - EL6xx, EL1xxx, EL5xxx, EL9xxx only
- ▶ Max. Surrounding Temperature 50 °C
 - EL8xx, EL2xxx, EL7xxx only
- ▶ Optional communication ratings:
 - RS232-Connection: max. 3 A
 - USB-Connection: max. 1 A
 - PS/2-Connection: max. 1 A
 - LAN-Connection: Standard ISDN or RJ45
- ▶ Environmental ratings: If these devices are mounted into a door or front cover of an enclosure: Type 1 enclosure.



Warnings!

Field Wiring Markings

Wiring Terminal MSTB 2,5/3-STF-5,08:

- ▶ Use Copper Wire only.
- ▶ AWG 18 ... AWG 12 (0.82 mm²... 3.3 mm²)
- ▶ Torque 5...7 lb-in (0.5 ... 0.6 Nm)

Power supply

- ▶ Must be used as isolating source.
- ▶ Rated data: 24 VDC, 4 A max.

Battery

- ▶ Replace Battery with any from the list below, Part No. CR 2450 only. Use of another battery may present a risk of fire or explosion.
Recommended CR2450 (R/C, BBVC2) types:
Renata Part.no. CR2450N, Sony Corp. part no. CR2450B, Toshiba part no. CR2450, Varta part no. CR2450, Matsushita part no. CR2450
- ▶ Battery may explode if mistreated. Do not recharge, disassemble, dispose of in fire or heat above 100 °C (212 °F).
- ▶ Dispose of used battery according to the regulation of recycling or waste.

3 Produktbeschreibung

Lieferumfang

3 Produktbeschreibung

3.1 Lieferumfang

Anzahl	Bezeichnung
1	Embedded Line Panel-PC
8	Schraubspanner EL 1800, EL 1800s, EL 1850, EL 1850s
4	EL 2800
6	EL 2850, EL 5800, EL 5820, EL 5850
5	EL 5870
6	EL 9800
1	Anschlussstecker für Spannungsversorgung
1	DVD "PC based Automation"
1	Testbericht
1	Gerätepass

3.2 Bedien- und Anzeigeelemente

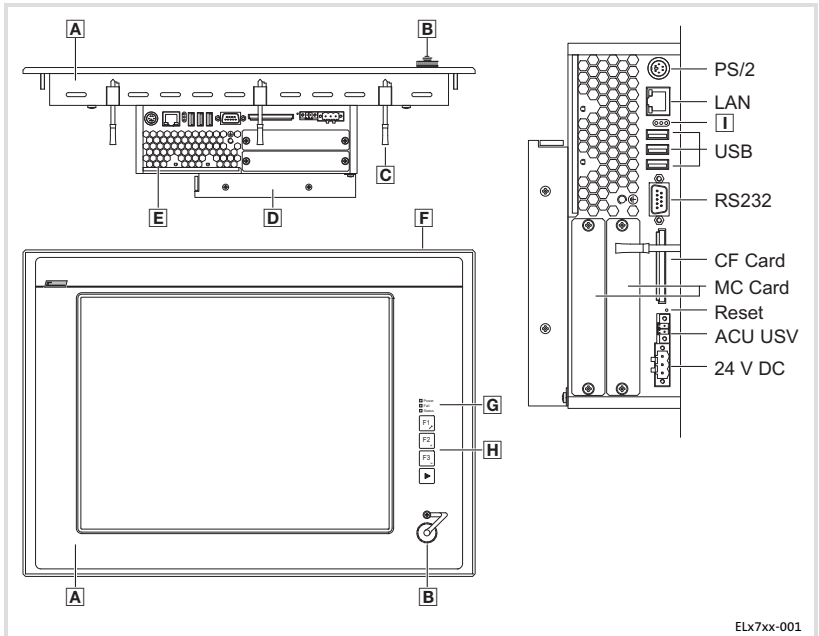

ELX7xx-001

Pos.	Beschreibung
A	Panel PC / Thin Client (hier Panel PC EL 5800)
B	Frontseitiger USB-Anschluss (Option)
C	Schraubspanner
D	DVD-Laufwerk (Option)
E	PC
F	Typenschild
G	Frontseitige Status-LEDs (Power, Fail, Status)
H	Frontseitige Bedienelemente
I	Status-LEDs (Error, HD, Power)

4 Installation

4.1 Wichtige Hinweise



Stop!

Empfindlicher Dichtring am Frontrahmen

Während der Montage liegt der Dichtring des Frontrahmens frei und kann beschädigt werden.

Mögliche Folgen:

- ▶ Die in den Technischen Daten genannte Schutzart wird nicht erreicht.

Schutzmaßnahmen:

- ▶ Gehen Sie während der Montage sorgsam mit dem Dichtring um.
- ▶ Schützen Sie den Dichtring vor UV-Strahlen.
- ▶ Kontrollieren Sie den Dichtring jedes Mal auf Unversehrtheit, bevor Sie das Gerät montieren.



Stop!

Kurzschluss und statische Entladungen

Das Gerät enthält Bauelemente, die bei Kurzschluss oder statischer Entladung gefährdet sind.

Mögliche Folgen:

- ▶ Das Gerät oder Teile davon werden zerstört.

Schutzmaßnahmen:

- ▶ Bei allen Arbeiten am Gerät, immer Spannungsversorgung abschalten. Dies gilt insbesondere:
 - vor dem Anschließen / Abziehen von Steckverbindern.
 - vor dem Stecken / Ziehen von Modulen.
- ▶ Alle Personen, die Flachbaugruppen handhaben, müssen ESD-Maßnahmen berücksichtigen.
- ▶ Kontakte von Steckverbindern dürfen nicht berührt werden.
- ▶ Flachbaugruppen dürfen nur an kontaktfreien Stellen angefasst werden und nur auf geeigneten Unterlagen abgelegt werden (z. B. auf ESD-Verpackung oder leitfähigem Schaumstoff).
- ▶ Flachbaugruppen dürfen nur in ESD-Verpackungen transportiert und gelagert werden.

4.2 Abmessungen

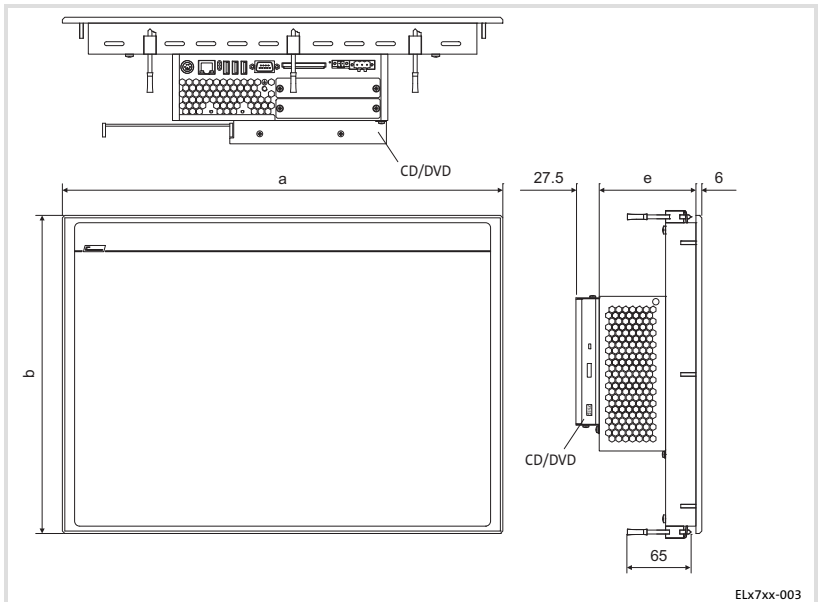

Alle Maße in Millimeter.

Abmessungen			
	a	b [mm]	e
EL 1800	325	240	99
EL 1800s			
EL 1850	365	300	
EL 1850s			
EL 2800	390	310	
EL 2850	425	325	
EL 5800	483	310 (7 HE)	
EL 5820		399 (9 HE)	
EL 5850			
EL 5870	490	400	109
EL 9800			

4.3 Einbauausschnitt

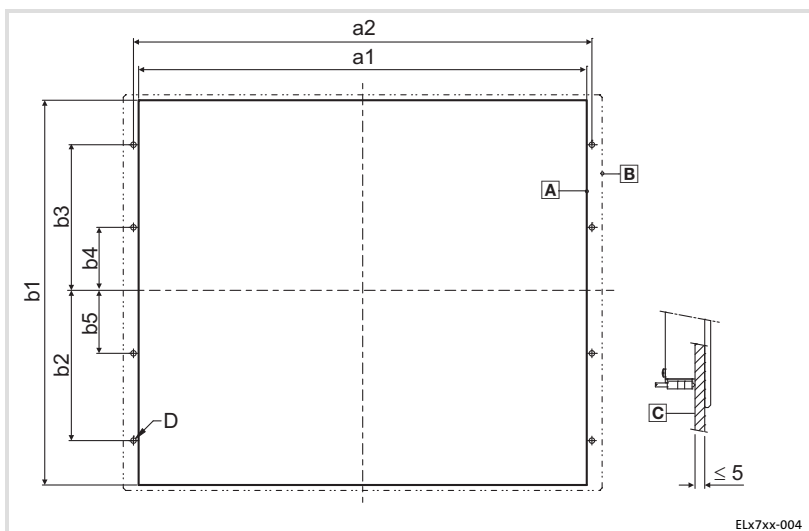

- A** Einbauausschnitt
- B** Kontur Frontrahmen
- C** Schalttafel

Alle Maße in Millimeter.

Abmessungen								
	a1	a2	b1	b2	b3	b4	b5	D
	[mm]							
EL 1800	305.0	-	228.0	-	-	-	-	-
EL 1800s								
EL 1850	343.0	-	228.0	-	-	-	-	-
EL 1850s								
EL 2800	340.0	351.0	288.0	122.0	122.0	0.0	-	6 x \varnothing 5.5
EL 2850	375.0	386.0	288.0	122.0	122.0	0.0	-	
EL 5800	400.0	411.0	313.0	134.5	134.5	0.0	-	
EL 5820	452.0	462.4	299.0	104.9	104.6	15.7	-	
EL 5850								
EL 5870								
EL 9800	438.0	451.0	386.0	172.0	172.0	60.0	60.0	8 x \varnothing 4.5

4.4 Montageschritte

4.4.1 Panel PC EL 1800(s) / EL 1850(s)

So gehen Sie bei der Montage vor:

1. Schneiden Sie den Einbauausschnitt in die Schalttafel (☞ 12).
2. Kontrollieren Sie, dass die Dichtung unter der Frontplatte korrekt liegt.
3. Setzen Sie das Gerät in den Einbauausschnitt, sichern Sie es mit einer Hand gegen Herunterfallen.
4. Montieren Sie alle Schraubspanner wie folgt:

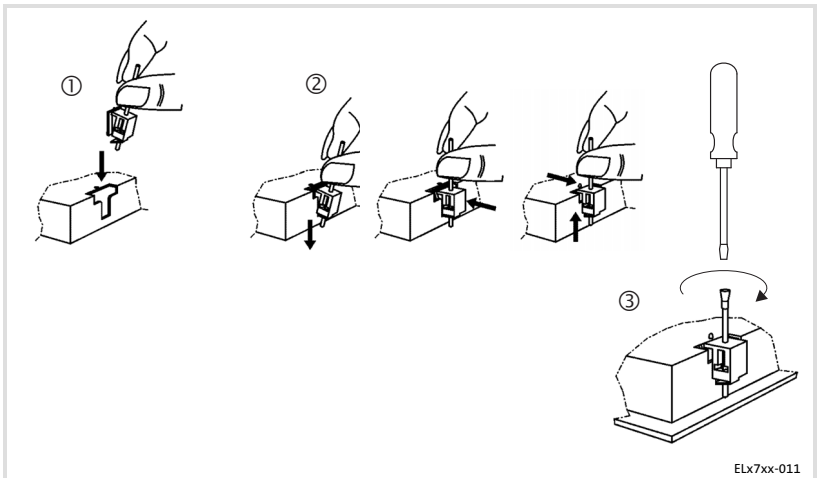

- Stecken Sie den Schraubspanner, wie in der Abbildung gezeigt, in die Öffnung am Gerätegehäuse.
 - Drücken Sie den Schraubspanner nach unten, kippen Sie ihn in Richtung Gehäuse und kontrollieren Sie, ob er korrekt eingerastet ist.
 - Ziehen Sie den Schraubspanner mit einem Schraubendreher handfest an.
5. Kontrollieren Sie, dass das Gerät fest im Einbauausschnitt sitzt und die Frontplattendichtung korrekt aufliegt.
 - Ggf. Gerät bzw. Dichtung neu ausrichten.
 - Wenn die Dichtung nicht korrekt sitzt, wird auf der Gerätevorderseite die Schutzklasse IP65 nicht erreicht!

4.4.2

Panel PC EL 2800 / EL 2850 / EL 5800 / EL 5820 / EL 5850 / EL 5870 / EL 9800

Schalttafel-Montage

So gehen Sie bei der Montage vor:

1. Schneiden Sie den Einbauausschnitt in die Schalttafel und bohren Sie die Befestigungslöcher in die Schalttafel (☞ 12).
2. Kontrollieren Sie, dass die Dichtung unter der Frontplatte korrekt liegt.
3. Setzen Sie das Gerät in den Einbauausschnitt, sichern Sie es mit einer Hand gegen Herunterfallen und schrauben Sie Muttern mit Scheiben auf die Gewindebolzen.
4. Montieren Sie alle Schraubspanner wie folgt:

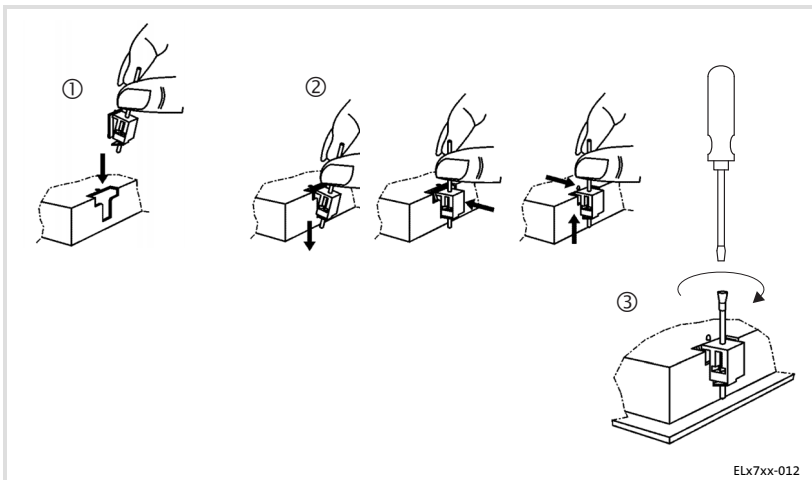

- Stecken Sie den Schraubspanner, wie in der Abbildung gezeigt, in die Öffnung am Gerätegehäuse.
 - Drücken Sie den Schraubspanner nach unten, kippen Sie ihn in Richtung Gehäuse und kontrollieren Sie, ob er korrekt eingerastet ist.
 - Ziehen Sie den Schraubspanner mit einem Schraubendreher handfest an.
5. Kontrollieren Sie, dass das Gerät fest im Einbauausschnitt sitzt und die Frontplattendichtung korrekt aufliegt.
 - Ggf. Gerät bzw. Dichtung neu ausrichten.
 - Wenn die Dichtung nicht korrekt sitzt, wird auf der Gerätevorderseite die Schutzklasse IP65 nicht erreicht!

19"-Baugruppenträger-Montage (nur EL 5820, EL 5850 und EL 5870)

So gehen Sie bei der Montage vor:

1. Entfernen Sie am Frontrahmen die rückseitigen Gewindestifte.
2. Bohren Sie am Frontrahmen die rückseitigen Sacklöcher mit einem 6.5-mm-Bohrer auf.
3. Setzen Sie das Gerät in den 19"-Baugruppenträger und schrauben Sie es fest.

4.5 Elektrische Installation

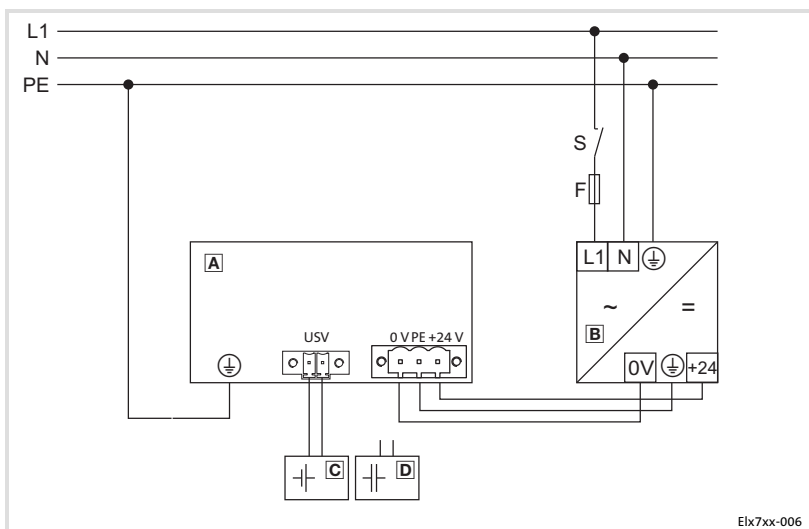

- A** IPC
- B** Netzteil
- C** Batteriepack (Option)
- D** Kondensatorpack (Option)

1	About this documentation	18
1.1	Notes used	18
2	Safety instructions	19
2.1	General safety information	19
2.2	Safety instructions for the installation according to UL	20
3	Product description	22
3.1	Scope of supply	22
3.2	Controls and displays	23
4	Installation	24
4.1	Important notes	24
4.2	Dimensions	25
4.3	Mounting cutout	26
4.4	Mounting steps	27
4.4.1	Panel PC EL 1800(s) / EL 1850(s)	27
4.4.2	Panel PC EL 2800 / EL 2850 / EL 5800 / EL 5820 / EL 5850 / EL 5870 / EL 9800	28
4.5	Electrical installation	30

1 About this documentation

Notes used

1 About this documentation

1.1 Notes used

The following pictographs and signal words are used in this documentation to indicate dangers and important information:

Safety instructions

Structure of safety instructions:





Danger!



(characterises the type and severity of danger)

Note

(describes the danger and gives information about how to prevent dangerous situations)

Pictograph and signal word	Meaning
 Danger!	Danger of personal injury through dangerous electrical voltage. Reference to an imminent danger that may result in death or serious personal injury if the corresponding measures are not taken.
 Danger!	Danger of personal injury through a general source of danger. Reference to an imminent danger that may result in death or serious personal injury if the corresponding measures are not taken.
 Stop!	Danger of property damage. Reference to a possible danger that may result in property damage if the corresponding measures are not taken.

Application notes

Pictograph and signal word	Meaning
 Note!	Important note to ensure troublefree operation
 Tip!	Useful tip for simple handling
	Reference to another documentation

2 Safety instructions

2.1 General safety information

For your own safety



Danger!

Disregarding the following basic safety measures may lead to severe personal injury and damage to material assets!

- ▶ Lenze drive and automation components ...
 - ... must only be used for the intended purpose.
 - ... must never be operated if damaged.
 - ... must never be subjected to technical modifications.
 - ... must never be operated unless completely assembled.
 - ... must never be operated without the covers/guards.
 - ... can - depending on their degree of protection - have live, movable or rotating parts during or after operation. Surfaces can be hot.
- ▶ For Lenze drive and automation components ...
 - ... only use approved accessories.
 - ... only use original manufacturer spare parts.
- ▶ All specifications of the corresponding enclosed documentation must be observed.

This is vital for a safe and trouble-free operation and for achieving the specified product features.

The procedural notes and circuit details provided in this document are proposals which the user must check for suitability for his application. The manufacturer does not accept any liability for the suitability of the specified procedures and circuit proposals.
- ▶ Only qualified skilled personnel are permitted to work with or on Lenze drive and automation components.

According to IEC 60364 or CENELEC HD 384, these are persons ...

 - ... who are familiar with the installation, assembly, commissioning and operation of the product,
 - ... possess the appropriate qualifications for their work,
 - ... and are acquainted with and can apply all the accident prevent regulations, directives and laws applicable at the place of use.

2.2 Safety instructions for the installation according to UL**Approval**

Underwriter Laboratories (UL), UL508 and CSA C22.2 No. 142-M1987, (UL File Number E236341)

Ratings

- ▶ Input 24 V DC, 65 W
- ▶ Max. Ambient Temperature 40 °C
 - EL6xx, EL1xxx, EL5xxx, EL9xxx only
- ▶ Max. Surrounding Temperature 50 °C
 - EL8xx, EL2xxx, EL7xxx only
- ▶ Optional communication ratings:
 - RS232-Connection: max. 3 A
 - USB-Connection: max. 1 A
 - PS/2-Connection: max. 1 A
 - LAN-Connection: Standard ISDN or RJ45
- ▶ Environmental ratings: If these devices are mounted into a door or front cover of an enclosure: Type 1 enclosure.



Warnings!

Field Wiring Markings

Wiring Terminal MSTB 2,5/3-STF-5,08:

- ▶ Use Copper Wire only.
- ▶ AWG 18 ... AWG 12 (0.82 mm²... 3.3 mm²)
- ▶ Torque 5...7 lb-in (0.5 ... 0.6 Nm)

Power supply

- ▶ Must be used as isolating source.
- ▶ Rated data: 24 VDC, 4 A max.

Battery

- ▶ Replace Battery with any from the list below, Part No. CR 2450 only. Use of another battery may present a risk of fire or explosion.
Recommended CR2450 (R/C, BBVC2) types:
Renata Part.no. CR2450N, Sony Corp. part no. CR2450B, Toshiba part no. CR2450, Varta part no. CR2450, Matsushita part no. CR2450
- ▶ Battery may explode if mistreated. Do not recharge, disassemble, dispose of in fire or heat above 100 °C (212 °F).
- ▶ Dispose of used battery according to the regulation of recycling or waste.

3 Product description

Scope of supply

3 Product description

3.1 Scope of supply

Quantity	Name
1	Embedded Line Panel PC
	Screw clamp fixings
8	EL 1800, EL 1800s, EL 1850, EL 1850s
4	EL 2800
6	EL 2850, EL 5800, EL 5820, EL 5850
5	EL 5870
6	EL 9800
1	Connection plug for voltage supply
1	DVD "PC based Automation"
1	Test report
1	Device pass card

3.2 Controls and displays

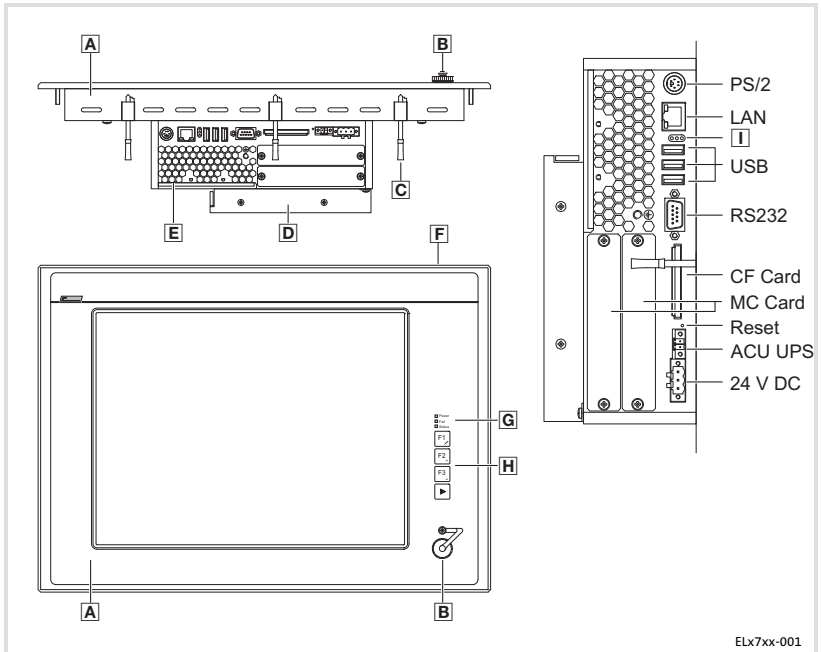

Pos.	Description
A	Panel PC / Thin Client (here Panel PC EL 5800)
B	Front face USB port (option)
C	Screw clamp fixings
D	DVD drive (optional)
E	PC
F	Nameplate
G	Front face status LEDs (Power, Fail, Status)
H	Front face control elements
I	Status LEDs (Error, HD, Power)

4 Installation

4.1 Important notes



Stop!

Sensitive front frame gasket

During mounting, the gasket of the front frame is exposed and can be damaged.

Possible consequences:

- ▶ The degree of protection provided by the enclosure mentioned in the technical data is not attained.

Protective measures:

- ▶ Handle the gasket with care during mounting.
- ▶ Protect the gasket against ultraviolet rays.
- ▶ Each time before you mount the device, check whether the gasket is intact.



Stop!

Short circuit and static discharge

The device contains components which are endangered in the case of short circuit or static discharge.

Possible consequences:

- ▶ The device or parts of it will be destroyed.

Protective measures:

- ▶ Always switch off the voltage supply when working on the device. This particularly applies:
 - Before connecting / disconnecting connectors.
 - Before plugging in / plugging out modules.
- ▶ All persons handling printed circuit boards have to take account of ESD measures.
- ▶ Contacts of plug connectors must not be touched.
- ▶ Printed circuit boards may be touched only at places free from electrical contacts and may be placed only on appropriate materials (e.g. on ESD packaging or conductive foam material).
- ▶ Printed circuit boards may only be transported and stored in ESD packaging.

4.2 Dimensions

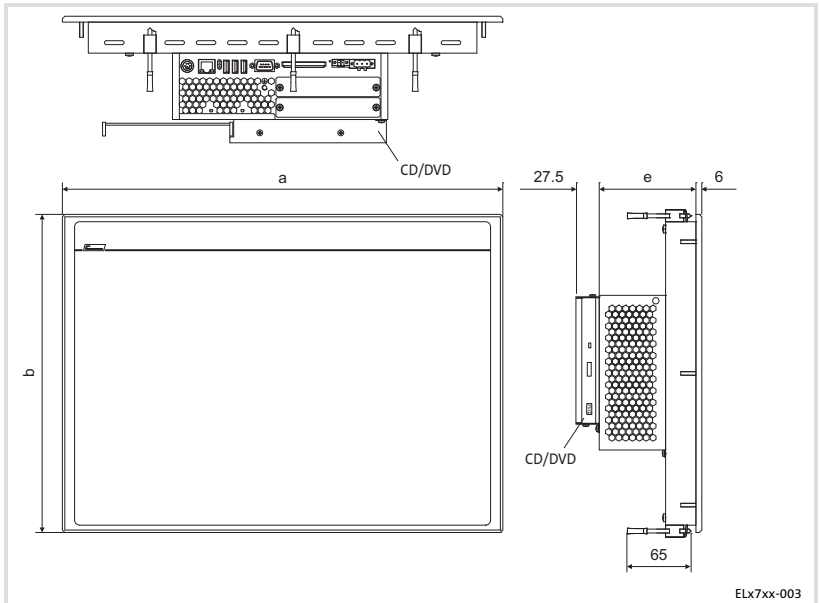

ELx7xx-003

All dimensions in millimetres.

Dimensions			
	a	b [mm]	e
EL 1800	325	240	99
EL 1800s			
EL 1850	365	300	
EL 1850s			
EL 2800	390	310	
EL 2850	425	325	
EL 5800	483	310 (7 U)	
EL 5820		399 (9 U)	
EL 5850			
EL 5870	490	400	109
EL 9800			

4 Installation

Mounting cutout

4.3 Mounting cutout

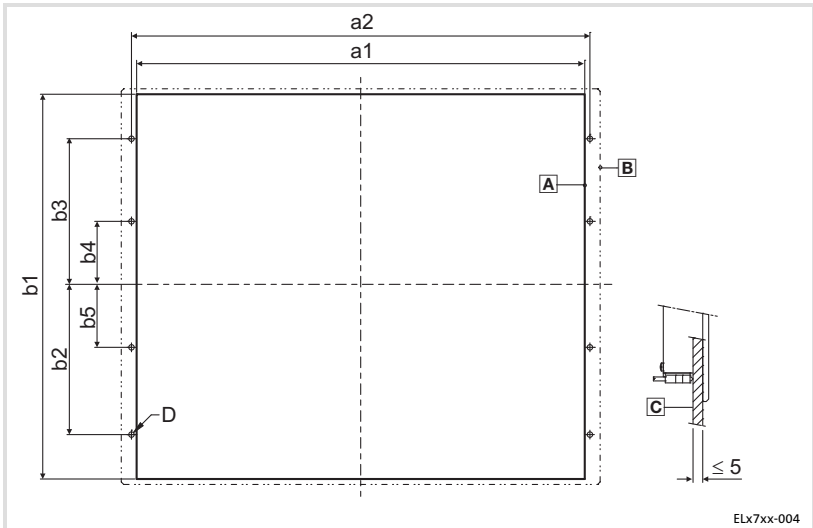

- A** Mounting cutout
- B** Outline of front panel
- C** Control board

All dimensions in millimetres.

Dimensions								
	a1	a2	b1	b2	b3	b4	b5	D
	[mm]							
EL 1800	305.0	-	228.0	-	-	-	-	-
EL 1800s								
EL 1850	343.0	-	228.0	-	-	-	-	-
EL 1850s								
EL 2800	340.0	351.0	288.0	122.0	122.0	0.0	-	6 x \varnothing 5.5
EL 2850	375.0	386.0	288.0	122.0	122.0	0.0	-	
EL 5800	400.0	411.0	313.0	134.5	134.5	0.0	-	
EL 5820	452.0	462.4	299.0	104.9	104.6	15.7	-	
EL 5850								
EL 5870	452.0	462.4	388.2	149.3	149.3	15.9	-	
EL 9800	438.0	451.0	386.0	172.0	172.0	60.0	60.0	8 x \varnothing 4.5

4.4 Mounting steps

4.4.1 Panel PC EL 1800(s) / EL 1850(s)

How to perform the installation:

1. Cut the mounting cutout into the control board ( 26).
2. Check that the gasket under the front panel is located correctly.
3. Place the device in the mounting cutout and secure it against falling-down with one hand.
4. Fit all screw clamp fixings as explained below:

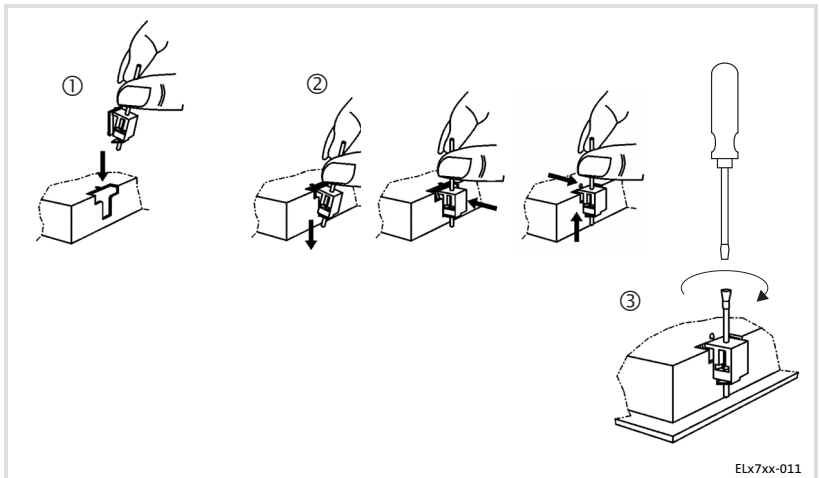

- Insert the screw clamp fixing into the slot in the housing of the device (see above figure).
 - Press the screw clamp fixing downwards, tilt it towards the housing and check that it has firmly snapped into place.
 - Tighten the screw clamp fixing hand-tight with a screwdriver.
5. Check that the device is securely located in the mounting cutout and that the front panel gasket is located correctly.
 - If necessary, realign the device/gasket.
 - If the gasket is not located correctly, protection class IP65 is not achieved on the front of the device!

4 Installation

Mounting steps

Panel PC EL 2800 / EL 2850 / EL 5800 / EL 5820 / EL 5850 / EL 5870 / EL 9800

4.4.2 Panel PC EL 2800 / EL 2850 / EL 5800 / EL 5820 / EL 5850 / EL 5870 / EL 9800

Control board mounting

How to perform the installation:

1. Prepare the control board by cutting the mounting cutout and drilling the mounting holes into it (see 26).
2. Check that the gasket under the front panel is located correctly.
3. Place the device in the mounting cutout, secure it by hand against falling down and screw the nuts and washers onto the threaded bolts.
4. Fit all screw clamp fixings as explained below:

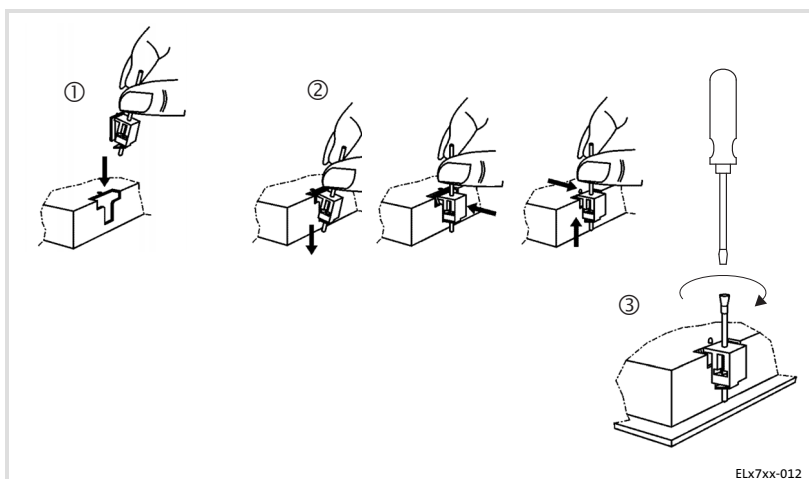

- Insert the screw clamp fixing into the slot in the housing of the device (see above figure).
 - Press the screw clamp fixing downwards, tilt it towards the housing and check that it has firmly snapped into place.
 - Tighten the screw clamp fixing hand-tight with a screwdriver.
5. Check that the device is securely located in the mounting cutout and that the front panel gasket is located correctly.
 - If necessary, realign the device/gasket.
 - If the gasket is not located correctly, protection class IP65 is not achieved on the front of the device!

Installation in 19" mounting racks (only EL 5820, EL 5850, and EL 5870)

How to perform the installation:ounting rack installation"#

1. Remove the set screws from the back of the front frame.
2. Drill through the blind holes at the back of the front frame using a 6.5 mm drill.
3. Place the device in the 19" mounting rack and screw it.

4 Installation

Electrical installation

4.5 Electrical installation

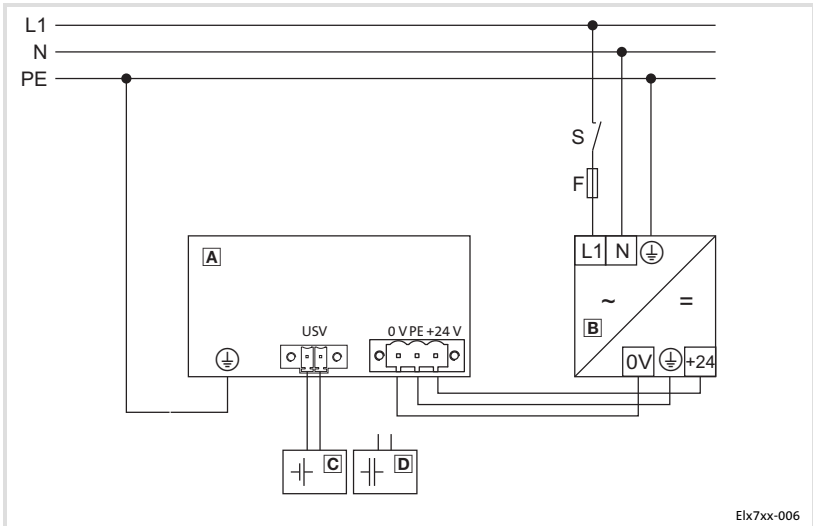

- A** IPC
- B** Power supply unit
- C** Battery pack (Option)
- D** Capacitor pack (Option)

1	Présentation du document	32
1.1	Consignes utilisées	32
2	Consignes de sécurité	33
2.1	Consignes générales	33
2.2	Consignes de sécurité pour l'installation selon UL	34
3	Description du produit	36
3.1	Équipement livré	36
3.2	Éléments de commande et d'affichage	37
4	Installation	38
4.1	Remarques importantes	38
4.2	Encombresments	40
4.3	Encoche de montage	41
4.4	Opérations de montage	42
4.4.1	Panel PC EL 1800(s) / EL 1850(s)	42
4.4.2	Panel PC EL 2800 / EL 2850 / EL 5800 / EL 5820 / EL 5850 / EL 5870 / EL 9800	43
4.5	Installation électrique	45

1 Présentation du document

Consignes utilisées

1 Présentation du document



1.1 Consignes utilisées

Pour indiquer des risques et des informations importantes, la présente documentation utilise les mots et pictogrammes suivants :



Consignes de sécurité

Présentation des consignes de sécurité

	Danger ! (Le pictogramme indique le type de risque.) Explication (L'explication décrit le risque et les moyens de l'éviter.)
---	---

Pictogramme et mot associé	Explication
 Danger !	Situation dangereuse pour les personnes en raison d'une tension électrique élevée Indication d'un danger imminent qui peut avoir pour conséquences des blessures mortelles ou très graves en cas de non-respect des consignes de sécurité correspondantes
 Danger !	Situation dangereuse pour les personnes en raison d'un danger d'ordre général Indication d'un danger imminent qui peut avoir pour conséquences des blessures mortelles ou très graves en cas de non-respect des consignes de sécurité correspondantes
 Stop !	Risques de dégâts matériels Indication d'un risque potentiel qui peut avoir pour conséquences des dégâts matériels en cas de non-respect des consignes de sécurité correspondantes

Consignes d'utilisation

Pictogramme et mot associé	Explication
 Remarque importante !	Remarque importante pour assurer un fonctionnement correct
 Conseil !	Conseil utile pour faciliter la mise en œuvre
	Renvoi à une autre documentation

2 Consignes de sécurité

2.1 Consignes générales

Conseils pour assurer votre sécurité



Danger !

Le non-respect des consignes de sécurité de base suivantes risque d'entraîner des blessures et des dommages matériels graves.

- ▶ Les composants d'entraînement et d'automatisation Lenze ...
 - ... doivent exclusivement être utilisés conformément à leur fonction.
 - ... ne doivent jamais être mis en service si des dommages sont décelés.
 - ... ne doivent jamais être modifiés d'un point de vue technique.
 - ... ne doivent jamais être mis en service s'ils ne sont pas montés intégralement.
 - ... ne doivent jamais être mis en service sans le capot obligatoire.
 - ... peuvent - selon l'indice de protection - contenir des pièces sous tension, en mouvement ou en rotation. Les surfaces peuvent être brûlantes.
- ▶ Pour les composants d'entraînement et d'automatisation Lenze ...
 - ... utiliser uniquement les accessoires homologués pour le produit.
 - ... utiliser uniquement les pièces détachées d'origine proposées par le constructeur.
- ▶ Respecter toutes les consignes indiquées dans la documentation jointe et associée.

Il s'agit de la condition préalable pour garantir un fonctionnement sûr et fiable et pour obtenir les caractéristiques du produit indiquées.

Des consignes et les instructions de câblage fournies dans ce document sont des recommandations. Leur validité pour l'application concernée doit être vérifiée. Le constructeur n'assume aucune responsabilité pour les dommages liés à un problème d'adéquation des procédures et plans de raccordement indiqués.
- ▶ Les travaux réalisés avec et au niveau des composants d'entraînement et d'automatisation Lenze ne doivent être exécutés que par un personnel qualifié et habilité.

Selon les normes CEI 60364 ou CENELEC HD 384, ces personnes doivent ...

 - ... connaître parfaitement l'installation, le montage, la mise en service et le fonctionnement du produit.
 - ... posséder les qualifications appropriées pour l'exercice de leur activité.
 - ... connaître toutes les prescriptions pour la prévention d'accidents, directives et lois applicables sur le lieu d'utilisation et être en mesure de les appliquer.

2 Consignes de sécurité

Consignes de sécurité pour l'installation selon U_L

2.2 Consignes de sécurité pour l'installation selon U_L

Approval

Underwriter Laboratories (UL), UL508 and CSA C22.2 No. 142-M1987, (UL File Number E236341)

Ratings

- ▶ Input 24 V DC, 65 W
- ▶ Max. Ambient Temperature 40 °C
 - EL6xx, EL1xxx, EL5xxx, EL9xxx only
- ▶ Max. Surrounding Temperature 50 °C
 - EL8xx, EL2xxx, EL7xxx only
- ▶ Optional communication ratings:
 - RS232-Connection: max. 3 A
 - USB-Connection: max. 1 A
 - PS/2-Connection: max. 1 A
 - LAN-Connection: Standard ISDN or RJ45
- ▶ Environmental ratings: If these devices are mounted into a door or front cover of an enclosure: Type 1 enclosure.



Warnings!

Field Wiring Markings

Wiring Terminal MSTB 2,5/3-STF-5,08:

- ▶ Use Copper Wire only.
- ▶ AWG 18 ... AWG 12 (0.82 mm²... 3.3 mm²)
- ▶ Torque 5...7 lb-in (0.5 ... 0.6 Nm)

Power supply

- ▶ Must be used as isolating source.
- ▶ Rated data: 24 VDC, 4 A max.

Battery

- ▶ Replace Battery with any from the list below, Part No. CR 2450 only. Use of another battery may present a risk of fire or explosion.
Recommended CR2450 (R/C, BBVC2) types:
Renata Part.no. CR2450N, Sony Corp. part no. CR2450B, Toshiba part no. CR2450, Varta part no. CR2450, Matsushita part no. CR2450
- ▶ Battery may explode if mistreated. Do not recharge, disassemble, dispose of in fire or heat above 100 °C (212 °F).
- ▶ Dispose of used battery according to the regulation of recycling or waste.

3 Description du produit

Equipement livré

3 Description du produit

3.1 Equipement livré

Quantité	Désignation
1	Embedded Line Panel-PC (Panel PC encastrable)
	Goujons
8	EL 1800, EL 1800s, EL 1850, EL 1850s
4	EL 2800
6	EL 2850, EL 5800, EL 5820, EL 5850
5	EL 5870
6	EL 9800
1	Connecteur d'alimentation
1	DVD "PC based Automation"
1	Rapport d'essai
1	Carte d'identification de l'appareil

3.2 Éléments de commande et d'affichage

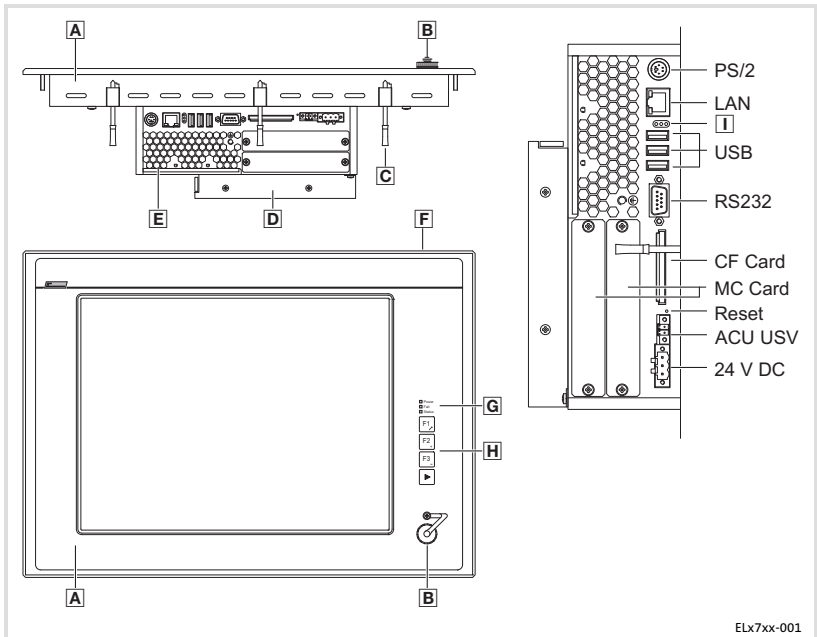

ELx7xx-001

Pos.	Description
A	Panel PC/Thin Client (client léger) (ici : Panel PC EL 5800)
B	Port USB sur la face avant (option)
C	Goujon
D	Lecteur de DVD (option)
E	PC
F	Plaque signalétique
G	LEDs d'état sur la face avant (Power, Fail, Status)
H	Éléments de commande et d'affichage sur la face avant
I	LEDs d'état (Error, HD, Power)

4 Installation

Remarques importantes

4 Installation

4.1 Remarques importantes



Stop !

Joint d'étanchéité fragile sur cadre avant

Pendant les opérations de montage, le joint d'étanchéité du cadre avant n'est pas protégé et risque alors d'être endommagé.

Risques encourus :

- ▶ L'indice de protection indiqué sous "Spécifications techniques" n'est pas atteint.

Mesures de protection :

- ▶ Pendant le montage, manipuler le joint d'étanchéité avec soin.
- ▶ Protéger le joint d'étanchéité contre les rayons UV.
- ▶ Avant chaque montage de l'appareil, vérifier l'intégrité du joint d'étanchéité.



Stop !

Court-circuits et décharges électrostatiques

L'appareil comprend des composants sensibles aux court-circuits ou aux décharges électrostatiques.

Risques encourus :

- ▶ Destruction de l'appareil ou de ces composants

Mesures de protection :

- ▶ Veiller à ce que l'appareil soit hors tension avant tous travaux sur celui-ci. Ceci est valable en particulier dans les cas de figure suivants :
 - Avant le raccordement/retrait de connecteurs enfichables
 - Avant l'enfichage/le retrait de modules
- ▶ Toute personne manipulant des cartes électroniques doit respecter les mesures relatives aux décharges électrostatiques (ESD).
- ▶ Ne pas toucher les contacts électriques des connecteurs enfichables.
- ▶ Toucher les cartes électroniques uniquement là où il n'y a pas de contacts électriques et les poser obligatoirement sur des supports appropriés (exemples : emballage ESD ou mousse synthétique conductrice).
- ▶ Utiliser impérativement les emballages ESD pour transporter ou stocker des cartes électroniques.

4 Installation

Encombremments

4.2 Encombremments

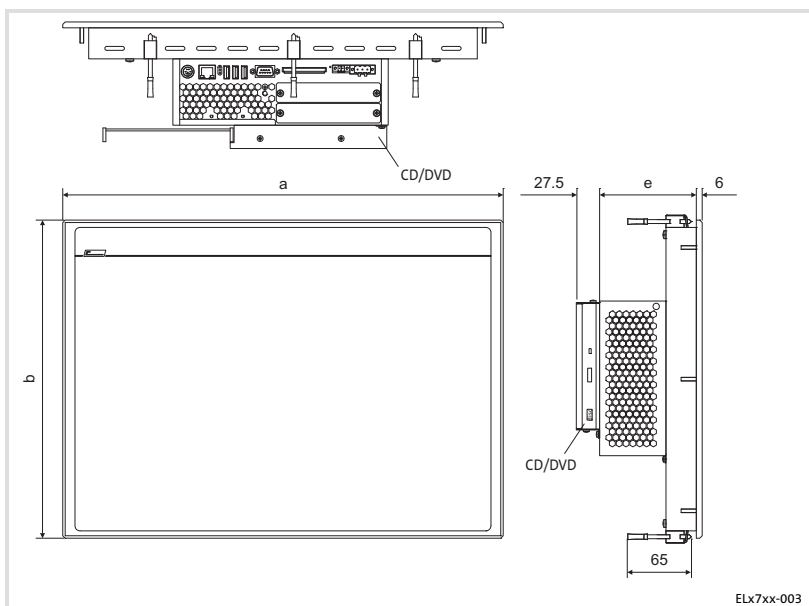

Cotes en [mm]

Encombremments			
	a	b [mm]	e
EL 1800	325	240	99
EL 1800s			
EL 1850	365	300	
EL 1850s			
EL 2800	390	310	
EL 2850	425	325	
EL 5800	450	310 (7 HE)	
EL 5820	483	399 (9 HE)	
EL 5850			
EL 5870			
EL 9800	490	400	109

4.3 Encoche de montage

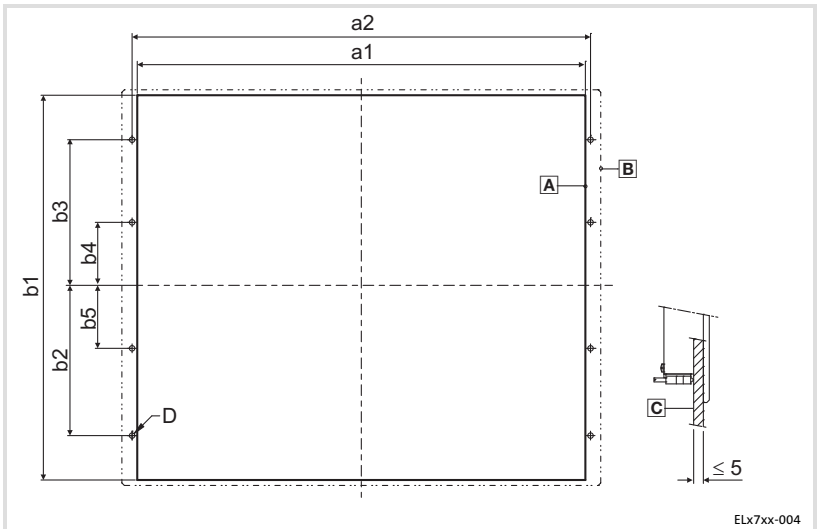

- A** Encoche de montage
- B** Contours du cadre avant
- C** Panneau de commande

Cotes en [mm]

Encombremnts								
	a1	a2	b1	b2	b3	b4	b5	D
	[mm]							
EL 1800	305.0	-	228.0	-	-	-	-	-
EL 1800s								
EL 1850	343.0	-	228.0	-	-	-	-	-
EL 1850s								
EL 2800	340.0	351.0	288.0	122.0	122.0	0.0	-	6 x Ø5.5
EL 2850	375.0	386.0	288.0	122.0	122.0	0.0	-	
EL 5800	400.0	411.0	313.0	134.5	134.5	0.0	-	
EL 5820	452.0	462.4	299.0	104.9	104.6	15.7	-	
EL 5850								
EL 5870	452.0	462.4	388.2	149.3	149.3	15.9	-	
EL 9800	438.0	451.0	386.0	172.0	172.0	60.0	60.0	8 x Ø4.5

4 Installation

Opérations de montage
Panel PC EL 1800(s) / EL 1850(s)

4.4 Opérations de montage

4.4.1 Panel PC EL 1800(s) / EL 1850(s)

Ordre des opérations de montage :

1. Réaliser la découpe pour le montage dans le panneau de commande (▣ 41).
2. Vérifier le positionnement correct du joint sous le cadre avant.
3. Insérer l'appareil dans l'encoche de montage. Le tenir à l'aide d'une main afin d'éviter qu'il tombe.
4. Monter les goujons dans l'ordre suivant :

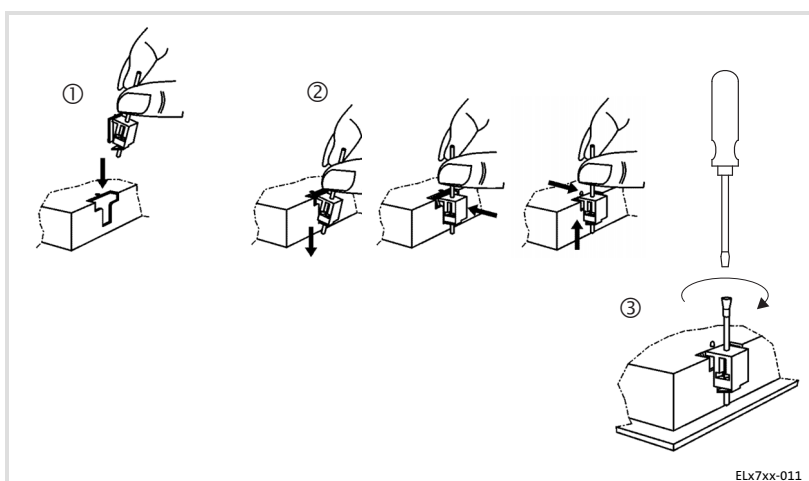

- Insérer le goujon dans l'ouverture sur le boîtier de l'appareil comme l'indique l'illustration.
 - Pousser le goujon vers le bas et le basculer côté boîtier. Vérifier s'il est correctement encliqueté.
 - Serrer le goujon à l'aide d'un tournevis. Ne pas trop serrer.
5. Vérifier si l'appareil est bien fixé dans l'encoche de montage et si le joint du cadre avant est correctement positionné.
 - Si nécessaire, réajuster l'appareil ou le joint.
 - L'indice de protection IP65 n'est pas atteint sur la face avant de l'appareil si le joint n'est pas correctement positionné !

4.4.2 Panel PC EL 2800 / EL 2850 / EL 5800 / EL 5820 / EL 5850 / EL 5870 / EL 9800**Montage dans le panneau de commande**

Ordre des opérations de montage :

1. Réaliser la découpe pour le montage dans le panneau de commande et percer les trous de fixation dans le panneau de commande (▢ 41).
2. Vérifier le positionnement correct du joint sous le cadre avant.
3. Insérer l'appareil dans l'encoche de montage. Le tenir à l'aide d'une main afin d'éviter qu'il tombe. Visser des écrous avec rondelles sur les boulons.
4. Monter les goujons dans l'ordre suivant :

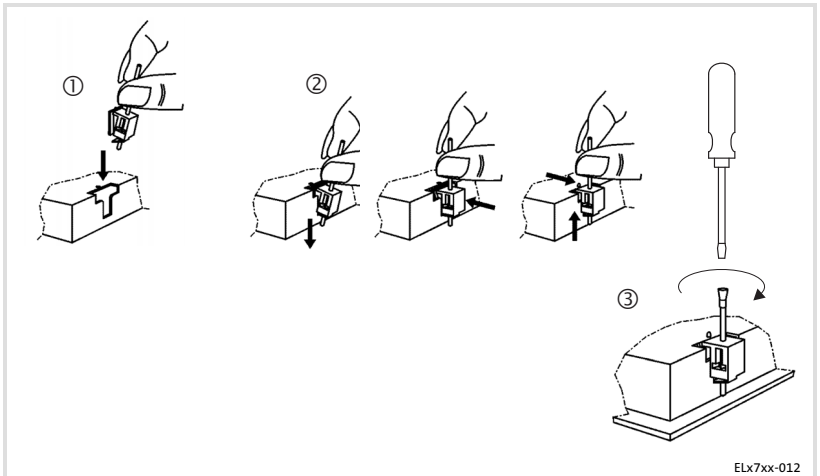

ELx7xx-012

- Insérer le goujon dans l'ouverture sur le boîtier de l'appareil comme l'indique l'illustration.
 - Pousser le goujon vers le bas et le basculer côté boîtier. Vérifier s'il est correctement encliqueté.
 - Serrer le goujon à l'aide d'un tournevis. Ne pas trop serrer.
5. Vérifier si l'appareil est bien fixé dans l'encoche de montage et si le joint du cadre avant est correctement positionné.
 - Si nécessaire, réajuster l'appareil ou le joint.
 - L'indice de protection IP65 n'est pas atteint sur la face avant de l'appareil si le joint n'est pas correctement positionné !

Montage du support de modules 19" (uniquement pour EL 5820, EL 5850 et EL 5870)

Ordre des opérations de montage :">#

1. Sur le cadre avant, retirer les boulons arrières.
2. Sur le cadre avant, percer les trous borgnes arrières à l'aide d'une perceuse et d'un foret de 6.5 mm.
3. Insérer l'appareil dans le support de modules 19" et le fixer à l'aide des vis.

4.5 Installation électrique

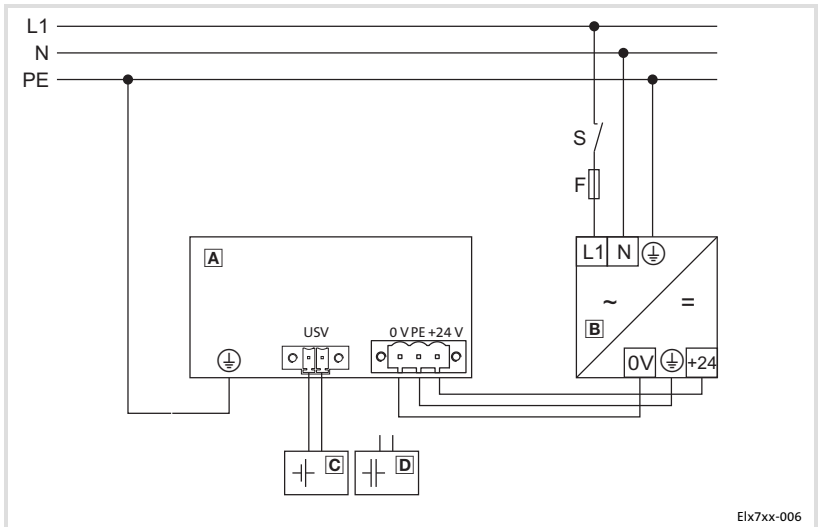

- Ⓐ PC industriel
- Ⓑ Bloc d'alimentation
- Ⓒ Pack de piles (option)
- Ⓓ Pack de condensateurs (option)

1	Acerca de esta documentación	48
1.1	Indicaciones utilizadas	48
2	Instrucciones de seguridad	49
2.1	Instrucciones generales de seguridad	49
2.2	Instrucciones de seguridad para la instalación según UL	50
3	Descripción del producto	52
3.1	Alcance del suministro	52
3.2	Elementos de mando y visualización	53
4	Instalación	54
4.1	Indicaciones importantes	54
4.2	Dimensiones	56
4.3	Sección de montaje	57
4.4	Pasos para el montaje	58
4.4.1	Panel PC EL 1800(s) / EL 1850(s)	58
4.4.2	Panel PC EL 2800 / EL 2850 / EL 5800 / EL 5820 / EL 5850 / EL 5870 / EL 9800	59
4.5	Instalación eléctrica	61

1 Acerca de esta documentación

Indicaciones utilizadas

1 Acerca de esta documentación

1.1 Indicaciones utilizadas

Para indicar peligros e información importante, se utilizan en esta documentación los siguientes términos indicativos y símbolos:

Instrucciones de seguridad

Estructura de las instrucciones de seguridad:





¡Peligro!



(indican el tipo y la gravedad del peligro)

Texto indicativo

(describe el peligro y da instrucciones para evitarlo)

Pictograma y término indicativo	Significado
 ¡Peligro!	Riesgo de daños personales por voltaje eléctrico Indica un peligro inminente que puede causar la muerte o lesiones graves si no se toman las medidas adecuadas.
 ¡Peligro!	Riesgo de daños personales por una fuente de riesgo general Indica un peligro inminente que puede causar la muerte o lesiones graves si no se toman las medidas adecuadas.
 ¡Alto!	Peligro de daños materiales Indica un posible riesgo que puede ocasionar daños materiales si no se toman las medidas adecuadas.

Instrucciones de uso

Pictograma y término indicativo	Significado
 ¡Aviso!	Nota importante para el funcionamiento sin fallos
 ¡Sugerencia!	Sugerencia útil para facilitar la operación
	Referencia a otra documentación

2 Instrucciones de seguridad

2.1 Instrucciones generales de seguridad

También para su propia seguridad



¡Peligro!

Si no se observan las siguientes instrucciones básicas de seguridad, pueden ocasionarse serios daños a personas y materiales:

- ▶ Los componentes de accionamiento y automatización de Lenze ...
 - ... sólo deben utilizarse de la manera adecuada.
 - ... nunca deben ponerse en funcionamiento si existen daños visibles.
 - ... nunca deben someterse a modificaciones técnicas.
 - ... nunca deben ponerse en funcionamiento si no están completamente montados.
 - ... nunca deben ponerse en funcionamiento sin las cubiertas necesarias.
 - ... pueden incluir durante y después del funcionamiento, y dependiendo de su grado de protección, piezas vivas, así como móviles y giratorias. Las superficies pueden estar calientes.
- ▶ Para componentes de accionamiento y automatización de Lenze ...
 - ... sólo utilizar los accesorios permitidos.
 - ... sólo utilizar piezas de recambio originales del fabricante.
- ▶ Observe todas las indicaciones de la documentación adjunta y la documentación correspondiente.

Es requisito esencial para un funcionamiento seguro y sin fallos, así como para lograr las características declaradas del producto.

Las indicaciones técnicas de procedimiento y secciones de conexión presentadas en este documento son propuestas, cuya transferibilidad a la aplicación correspondiente deberá ser comprobada. El fabricante no se hace responsable de la aptitud de los procedimientos y propuestas de conexión que se indican.
- ▶ Todos los trabajos con y en componentes de accionamiento y automatización de Lenze sólo deben ser realizados por personal experto cualificado.

Según IEC 60364 o resp. CENELEC HD 384 se trata de personas, ...

 - ... que conocen la instalación, el montaje, la puesta en marcha y la operación del producto.
 - ... que disponen de las cualificaciones correspondientes a su trabajo.
 - ... que conocen y saben aplicar todas las normas de prevención de accidentes, directivas y leyes aplicables en el lugar de uso.

2.2 Instrucciones de seguridad para la instalación según U_I**Approval**

Underwriter Laboratories (UL), UL508 and CSA C22.2 No. 142-M1987, (UL File Number E236341)

Ratings

- ▶ Input 24 V DC, 65 W
- ▶ Max. Ambient Temperature 40 °C
 - EL6xx, EL1xxx, EL5xxx, EL9xxx only
- ▶ Max. Surrounding Temperature 50 °C
 - EL8xx, EL2xxx, EL7xxx only
- ▶ Optional communication ratings:
 - RS232-Connection: max. 3 A
 - USB-Connection: max. 1 A
 - PS/2-Connection: max. 1 A
 - LAN-Connection: Standard ISDN or RJ45
- ▶ Environmental ratings: If these devices are mounted into a door or front cover of an enclosure: Type 1 enclosure.



Warnings!

Field Wiring Markings

Wiring Terminal MSTB 2,5/3-STF-5,08:

- ▶ Use Copper Wire only.
- ▶ AWG 18 ... AWG 12 (0.82 mm²... 3.3 mm²)
- ▶ Torque 5...7 lb-in (0.5 ... 0.6 Nm)

Power supply

- ▶ Must be used as isolating source.
- ▶ Rated data: 24 VDC, 4 A max.

Battery

- ▶ Replace Battery with any from the list below, Part No. CR 2450 only. Use of another battery may present a risk of fire or explosion.

Recommended CR2450 (R/C, BBVC2) types:

Renata Part.no. CR2450N, Sony Corp. part no. CR2450B, Toshiba part no. CR2450, Varta part no. CR2450, Matsushita part no. CR2450

- ▶ Battery may explode if mistreated. Do not recharge, disassemble, dispose of in fire or heat above 100 °C (212 °F).
- ▶ Dispose of used battery according to the regulation of recycling or waste.

3 Descripción del producto

Alcance del suministro

3 Descripción del producto

3.1 Alcance del suministro

Cantidad	Denominación
1	Embedded Line Panel-PC
	Tornillos tensores
8	EL 1800, EL 1800s, EL 1850, EL 1850s
4	EL 2800
6	EL 2850, EL 5800, EL 5820, EL 5850
5	EL 5870
6	EL 9800
1	Conector para el suministro de voltaje
1	DVD "PC based Automation"
1	Informe de ensayo
1	Pasaporte del equipo

3.2 Elementos de mando y visualización

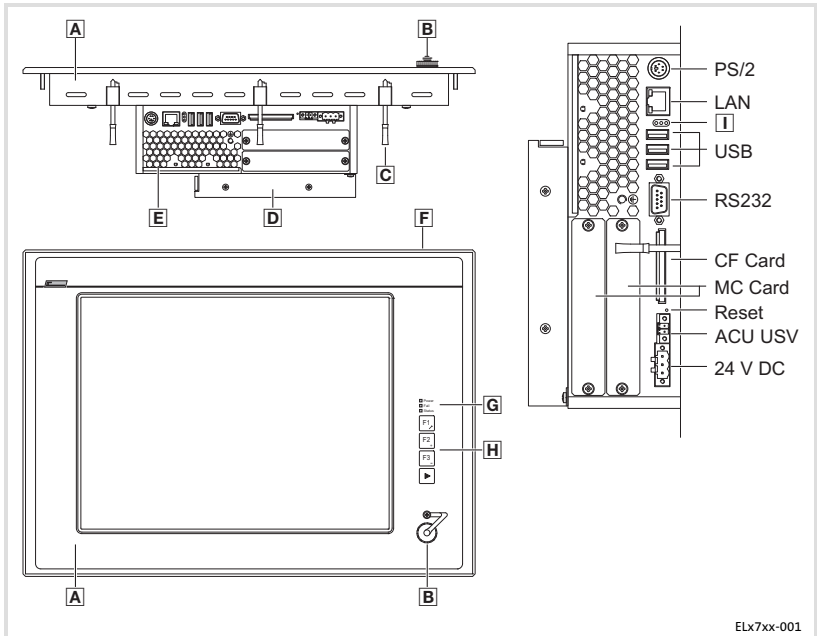

ELx7xx-001

Pos.	Descripción
A	Panel PC / Thin Client (aquí Panel PC EL 5800)
B	Conexión USB frontal (opcional)
C	Tornillos tensores
D	Unidad de DVD (opcional)
E	PC
F	Placa de características
G	LEDs de estado frontales (Power, Fail, Status)
H	Elementos de mando y visualización frontales
I	LEDs de estado (Error, HD, Power)

4 Instalación

4.1 Indicaciones importantes



¡Alto!

Anillo obturador sensible en el marco frontal.

Durante el montaje, el anillo obturador del marco frontal queda expuesto y puede resultar dañado.

Posibles consecuencias:

- ▶ No se alcanzará el tipo de protección indicado en los datos técnicos.

Medidas de protección:

- ▶ Tenga cuidado con el anillo obturador durante el montaje.
- ▶ Proteja el anillo obturador contra rayos UV.
- ▶ Compruebe siempre que el anillo obturador esté en perfecto estado antes de montar el equipo.



¡Alto!

Cortocircuito y descargas estáticas

El equipo contiene elementos que pueden resultar dañados en caso de cortocircuito o descarga estática.

Posibles consecuencias:

- ▶ El equipo o partes de éste podrían resultar dañados.

Medidas de protección:

- ▶ Siempre desconectar el suministro de voltaje al trabajar en el equipo. Esto es especialmente de aplicación:
 - antes de enchufar/desenchufar conectores.
 - antes de enchufar/desenchufar módulos.
- ▶ Todas las personas que trabajen con subconjuntos planos, deben tener en cuenta las medidas relativas a las descargas electrostáticas (ESD).
- ▶ No se deben tocar los contactos de conectores enchufables.
- ▶ Los subconjuntos planos sólo deben tocarse en puntos libres de contacto y colocarse solamente sobre bases adecuadas (p.e. sobre embalaje ESD o goma-espuma conductora).
- ▶ Los subconjuntos planos sólo deben ser transportados en embalajes ESD.

4 Instalación

Dimensiones

4.2 Dimensiones

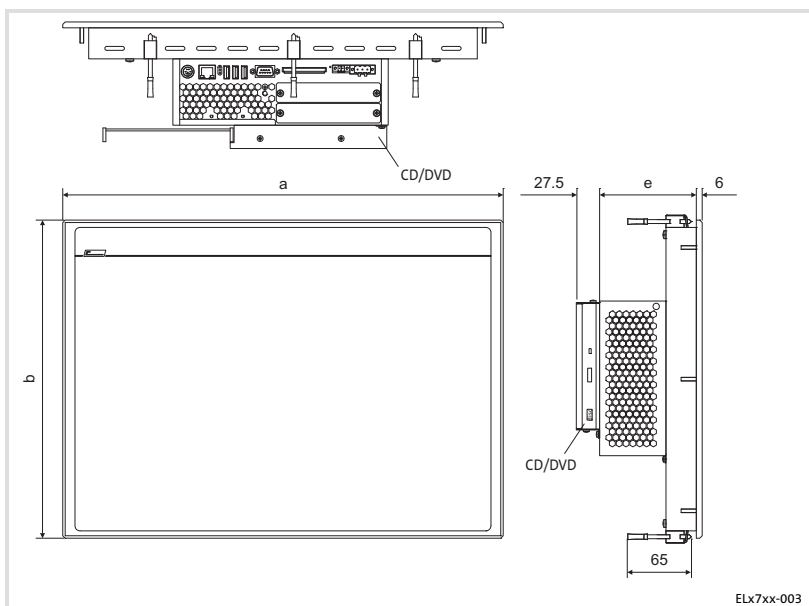

Todas las medidas en milímetros.

Dimensiones			
	a	b	e
		[mm]	
EL 1800	325	240	99
EL 1800s			
EL 1850	365	300	
EL 1850s			
EL 2800	390	310	
EL 2850	425	325	
EL 5800	483	310 (7 HE)	
EL 5820		399 (9 HE)	
EL 5850			
EL 5870			
EL 9800	490	400	109

4.3 Sección de montaje

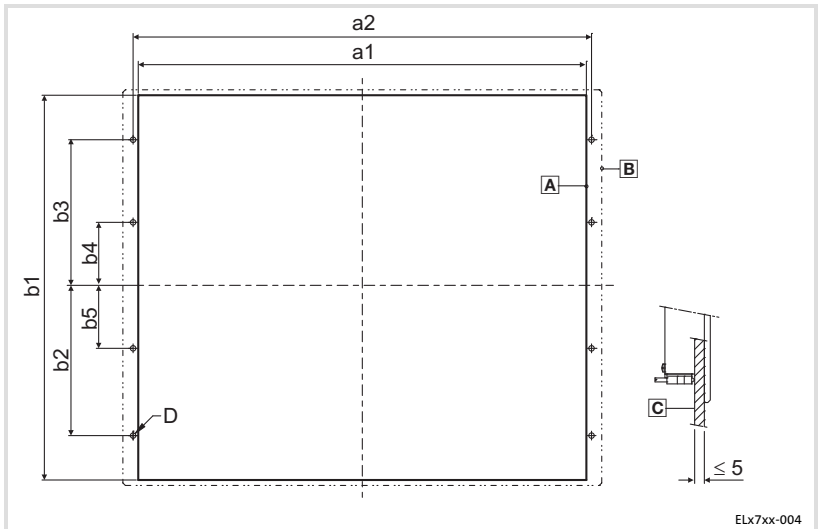

- A** Sección de montaje
- B** Contorno marco frontal
- C** Cuadro de mando
- D**

Todas las medidas en milímetros.

Dimensiones								
	a1	a2	b1	b2	b3	b4	b5	D
	[mm]							
EL 1800	305.0	-	228.0	-	-	-	-	-
EL 1800s								
EL 1850	343.0	-	228.0	-	-	-	-	-
EL 1850s								
EL 2800	340.0	351.0	288.0	122.0	122.0	0.0	-	6 x Ø5.5
EL 2850	375.0	386.0	288.0	122.0	122.0	0.0	-	
EL 5800	400.0	411.0	313.0	134.5	134.5	0.0	-	
EL 5820	452.0	462.4	299.0	104.9	104.6	15.7	-	
EL 5850								
EL 5870	452.0	462.4	388.2	149.3	149.3	15.9	-	
EL 9800	438.0	451.0	386.0	172.0	172.0	60.0	60.0	8 x Ø4.5

4 Instalación

Pasos para el montaje
Panel PC EL 1800(s) / EL 1850(s)

4.4 Pasos para el montaje

4.4.1 Panel PC EL 1800(s) / EL 1850(s)

Para el montaje, proceda de la siguiente manera:

1. Realizar el recorte de montaje en el cuadro de mando (▫ 57).
2. Controlar que la junta debajo de la placa frontal esté colocada correctamente.
3. Colocar el equipo en el recorte realizado y asegurarlo con la mano para que no caiga.
4. Montar los tornillos tensores de la siguiente manera:

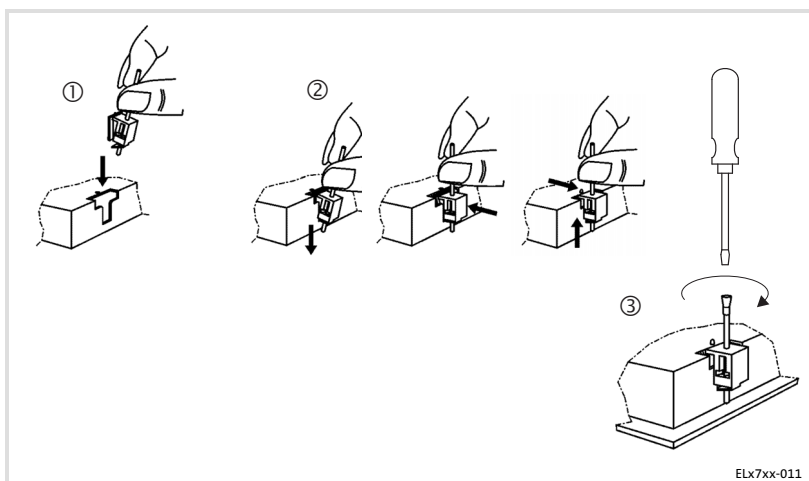

- Insertar el tornillo tensor, como se muestra en la imagen, en la abertura correspondiente de la carcasa del equipo.
 - Apretar el tornillo tensor hacia abajo, inclinarlo hacia la carcasa y controlar si ha encajado correctamente.
 - Apretar el tornillo tensor a mano con la ayuda de un atornillador.
5. Controlar que el equipo esté colocado firmemente en el recorte de montaje y que la junta de la placa frontal esté en posición correcta.
 - Recolocar el equipo o la junta si fuese necesario.
 - ¡Si la junta no está colocada correctamente no se alcanzará la protección IP65 en la cara frontal del equipo!

4.4.2 Panel PC EL 2800 / EL 2850 / EL 5800 / EL 5820 / EL 5850 / EL 5870 / EL 9800

Montaje del cuadro de mando

Para el montaje, proceda de la siguiente manera:

1. Realizar el recorte de montaje en el cuadro de mando y taladrar los agujeros de sujeción (ver 57).
2. Controlar que la junta debajo de la placa frontal esté colocada correctamente.
3. Colocar el equipo en el recorte realizado y asegurarlo con la mano para que no caiga. A continuación atornillar las tuercas con arandelas en los pernos roscados.
4. Montar los tornillos tensores de la siguiente manera:

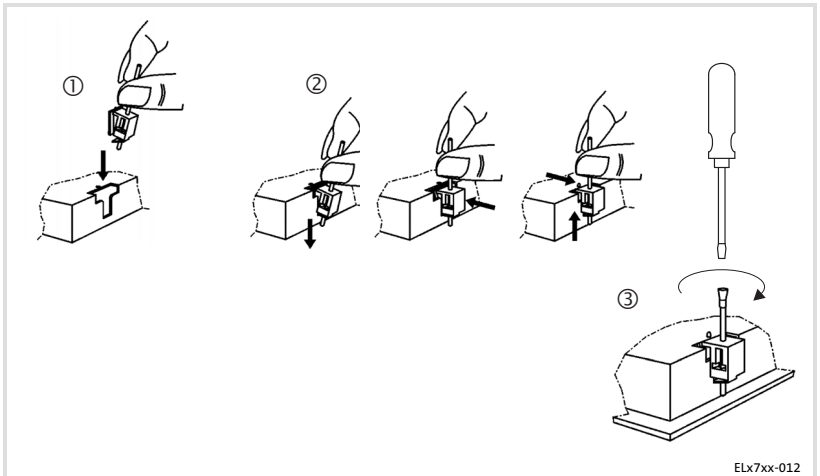

- Insertar el tornillo tensor, como se muestra en la imagen, en la abertura correspondiente de la carcasa del equipo.
 - Apretar el tornillo tensor hacia abajo, inclinarlo hacia la carcasa y controlar si ha encajado correctamente.
 - Apretar el tornillo tensor a mano con la ayuda de un atornillador.
5. Controlar que el equipo esté colocado firmemente en el recorte de montaje y que la junta de la placa frontal esté en posición correcta.
 - Recolocar el equipo o la junta si fuese necesario.
 - ¡Si la junta no está colocada correctamente no se alcanzará la protección IP65 en la cara frontal del equipo!

Montaje del soporte de 19" (sólo EL 5820, EL 5850 y EL 5870)

Para el montaje, proceda de la siguiente manera:

1. Retirar los pasadores roscados en la parte posterior del marco frontal.
2. Taladrar en el marco frontal los agujeros ciegos en la parte trasera con una broca de 6.5 mm.
3. Colocar el equipo en el soporte de 19" y atornillarlo firmemente.

4.5 Instalación eléctrica

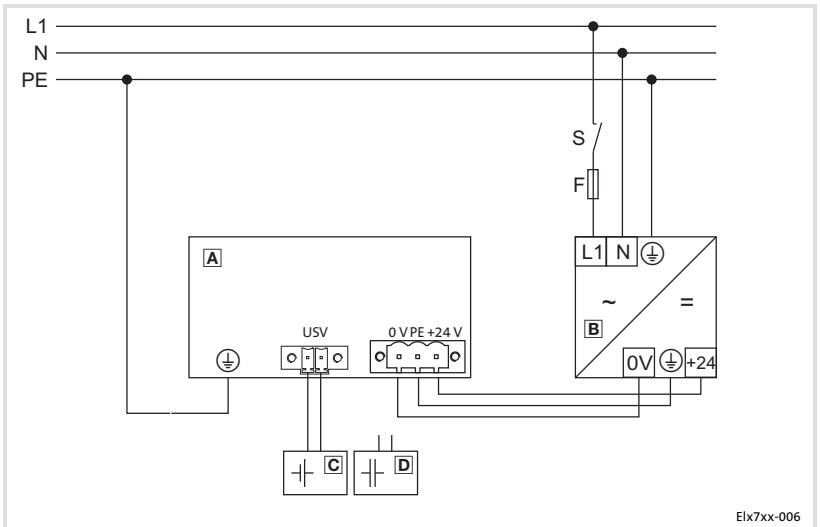

- Ⓐ IPC
- Ⓑ Fuente de red
- Ⓒ Pack de baterías (opcional)
- Ⓓ Pack de condensadores (opcional)

1	Informazioni sul manuale	64
1.1	Avvertenze utilizzate	64
2	Informazioni sulla sicurezza	65
2.1	Note generali di sicurezza	65
2.2	Informazioni sulla sicurezza per l'installazione secondo UL o UR	66
3	Descrizione del prodotto	68
3.1	Oggetto della fornitura	68
3.2	Elementi di comando e visualizzazione	69
4	Installazione	70
4.1	Note importanti	70
4.2	Dimensioni	72
4.3	Apertura di montaggio	73
4.4	Procedura di montaggio	74
4.4.1	Panel PC EL 1800(s) / EL 1850(s)	74
4.4.2	Panel PC EL 2800 / EL 2850 / EL 5800 / EL 5820 / EL 5850 / EL 5870 / EL 9800	75
4.5	Installazione elettrica	77

1 Informazioni sul manuale

Avvertenze utilizzate

1 Informazioni sul manuale

1.1 Avvertenze utilizzate

Per segnalare pericoli ed informazioni importanti, nella presente documentazione sono riportati i seguenti simboli e parole di segnalazione:

Note di sicurezza

Struttura delle note di sicurezza:





Pericolo!



(indica il tipo e la gravità del pericolo)

Testo della nota

(descrive il pericolo e fornisce indicazioni su come può essere evitato)

Simbolo e parola di segnalazione	Significato
 Pericolo!	Pericolo di danni alle persone dovuti a tensione elettrica Segnala una situazione di pericolo che può provocare morte o gravi lesioni se non vengono osservate le necessarie misure precauzionali.
 Pericolo!	Pericolo di danni alle persone dovuti a una fonte generica di pericolo Segnala una situazione di pericolo che può provocare morte o gravi lesioni se non vengono osservate le necessarie misure precauzionali.
 Stop!	Pericolo di danni materiali Segnala un possibile pericolo che può provocare danni materiali se non vengono osservate le necessarie misure precauzionali.

Note di utilizzo

Simbolo e parola di segnalazione	Significato
 Avvertenza:	Avvertenza importante per assicurare un corretto funzionamento dell'apparecchiatura
 Suggerimento:	Utile suggerimento per un più semplice utilizzo
	Rimando ad altra documentazione

2 Informazioni sulla sicurezza

2.1 Note generali di sicurezza

Anche per la propria sicurezza



Pericolo!

La mancata osservanza delle seguenti misure fondamentali di sicurezza può provocare gravi danni a persone e cose.

- ▶ Relativamente ai componenti di azionamento e automazione Lenze, osservare quanto segue:
 - utilizzare tali componenti esclusivamente in conformità agli usi preposti
 - non mettere mai in funzione tali componenti in caso di danni evidenti
 - non effettuare in nessun caso modifiche tecniche
 - non mettere mai in funzione tali componenti in caso di montaggio incompleto
 - non azionare mai tali componenti senza le coperture richieste in funzione del grado di protezione, durante o dopo il funzionamento tali componenti possono presentare parti sotto tensione, mobili o rotanti; le superfici possono essere ustionanti.
- ▶ Per i componenti di azionamento e automazione Lenze, utilizzare ...
 - ... solo gli accessori omologati
 - ... solo le parti di ricambio originali del costruttore.
- ▶ Osservare tutte le istruzioni e avvertenze fornite nella documentazione in dotazione e pertinente.

Solo in questo modo è possibile assicurare un funzionamento sicuro e senza problemi, nonché caratteristiche del prodotto conformi alle specifiche. Le specifiche, le procedure e gli schemi di collegamento forniti nel presente documento sono suggerimenti per i quali è necessario verificare l'applicabilità al singolo caso. Il produttore non si assume alcuna responsabilità per l'idoneità delle procedure e degli schemi di collegamento proposti.

- ▶ Tutti gli interventi relativi ai componenti di azionamento e automazione Lenze devono essere eseguiti esclusivamente da personale specializzato qualificato.
Secondo la normativa IEC 60364, ovvero CENELEC HD 384, per personale qualificato si intende:
personale che ha acquisito familiarità con l'installazione, il montaggio, la messa in servizio e il funzionamento del prodotto;
personale che dispone delle necessarie qualifiche grazie all'esperienza maturata;
personale che conosce ed è in grado di applicare tutte le disposizioni antinfortunistiche, le direttive e le norme vigenti nel luogo di installazione.

2.2 Informazioni sulla sicurezza per l'installazione secondo U_L o U_R

Approval

Underwriter Laboratories (UL), UL508 and CSA C22.2 No. 142-M1987, (UL File Number E236341)

Ratings

- ▶ Input 24 V DC, 65 W
- ▶ Max. Ambient Temperature 40 °C
 - EL6xx, EL1xxx, EL5xxx, EL9xxx only
- ▶ Max. Surrounding Temperature 50 °C
 - EL8xx, EL2xxx, EL7xxx only
- ▶ Optional communication ratings:
 - RS232-Connection: max. 3 A
 - USB-Connection: max. 1 A
 - PS/2-Connection: max. 1 A
 - LAN-Connection: Standard ISDN or RJ45
- ▶ Environmental ratings: If these devices are mounted into a door or front cover of an enclosure: Type 1 enclosure.



Warnings!

Field Wiring Markings

Wiring Terminal MSTB 2,5/3-STF-5,08:

- ▶ Use Copper Wire only.
- ▶ AWG 18 ... AWG 12 (0.82 mm²... 3.3 mm²)
- ▶ Torque 5...7 lb-in (0.5 ... 0.6 Nm)

Power supply

- ▶ Must be used as isolating source.
- ▶ Rated data: 24 VDC, 4 A max.

Battery

- ▶ Replace Battery with any from the list below, Part No. CR 2450 only. Use of another battery may present a risk of fire or explosion.

Recommended CR2450 (R/C, BBVC2) types:

Renata Part.no. CR2450N, Sony Corp. part no. CR2450B, Toshiba part no. CR2450, Varta part no. CR2450, Matsushita part no. CR2450

- ▶ Battery may explode if mistreated. Do not recharge, disassemble, dispose of in fire or heat above 100 °C (212 °F).
- ▶ Dispose of used battery according to the regulation of recycling or waste.

3 Descrizione del prodotto

Oggetto della fornitura

3 Descrizione del prodotto

3.1 Oggetto della fornitura

Quantità	Denominazione
1	Embedded Line Panel PC
	Serravite
8	EL 1800, EL 1800s, EL 1850, EL 1850s
4	EL 2800
6	EL 2850, EL 5800, EL 5820, EL 5850
5	EL 5870
6	EL 9800
1	Connettore di collegamento per alimentazione
1	DVD "PC based Automation"
1	Rapporto di prova
1	Libretto dell'apparecchio

3.2 Elementi di comando e visualizzazione

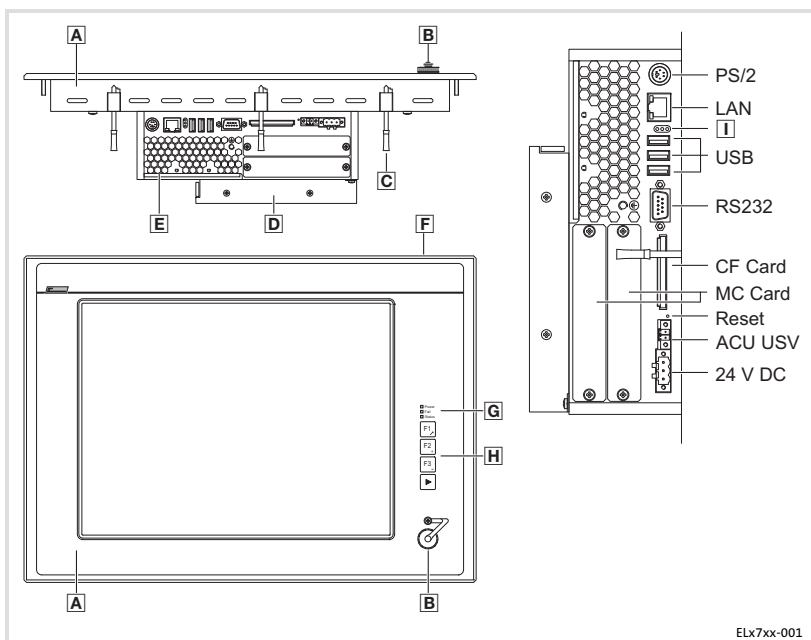

ELx7xx-001

Pos.	Descrizione
A	Panel PC / Thin Client (qui Panel PC EL 5800)
B	Pres a USB frontale (opzionale)
C	Serravite
D	Unità DVD (opzionale)
E	PC
F	Targhetta
G	LED di stato frontale (Power, Fail, Status)
H	Elementi di comando e visualizzazione sul lato frontale
I	LED di stato (Error, HD, Power)

4 Installazione

Note importanti

4 Installazione

4.1 Note importanti



Stop!

Anello di tenuta sensibile sul telaio frontale

Durante il montaggio l'anello di tenuta del telaio frontale è esposto e può danneggiarsi.

Possibili conseguenze:

- ▶ Il grado di protezione riportato nei dati tecnici non viene raggiunto.

Misure di protezione:

- ▶ Durante il montaggio maneggiare con cautela l'anello di tenuta.
- ▶ Proteggere l'anello di tenuta dai raggi UV.
- ▶ Prima di montare l'apparecchio, controllare ogni volta l'integrità dell'anello di tenuta.



Stop!

Cortocircuito e scariche elettrostatiche

L'apparecchio include componenti che sono in pericolo in caso di cortocircuito o scariche elettrostatiche.

Possibili conseguenze:

- ▶ Distruzione dell'apparecchio o di sue parti.

Misure di protezione:

- ▶ Quando si eseguono interventi sull'apparecchio, scollegare sempre l'alimentazione. Questo vale in particolare:
 - prima di collegare / scollegare connettori a innesto.
 - prima di inserire / disinserire moduli.
- ▶ Tutte le persone che maneggiano schede a circuiti stampati devono osservare le misure di protezione ESD.
- ▶ Non toccare i contatti di connettori a innesto.
- ▶ Le schede a circuiti stampati possono essere toccate solo nei punti privi di contatti e collocate solo su superfici di appoggio adeguate (ad es. su materiale d'imballaggio ESD o schiuma conduttiva).
- ▶ Le schede a circuiti stampati possono essere trasportate e conservate solo in imballaggi ESD idonei.

4 Installazione

Dimensioni

4.2 Dimensioni

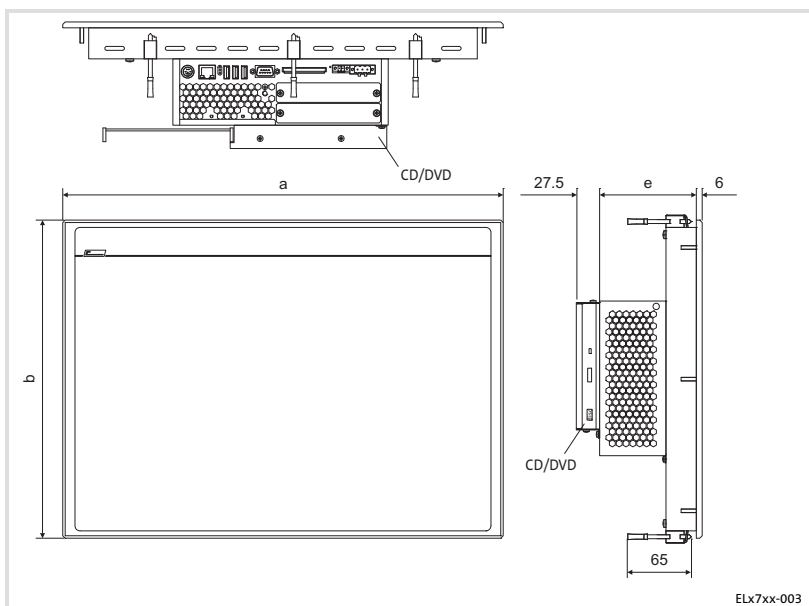

Tutte le quote sono in millimetri.

Dimensioni			
	a	b [mm]	e
EL 1800	325	240	99
EL 1800s			
EL 1850	365	300	
EL 1850s			
EL 2800	390	310	
EL 2850	425	325	
EL 5800	483	310 (7 HE)	
EL 5820		399 (9 HE)	
EL 5850			
EL 5870			
EL 9800	490	400	109

4.3 Apertura di montaggio

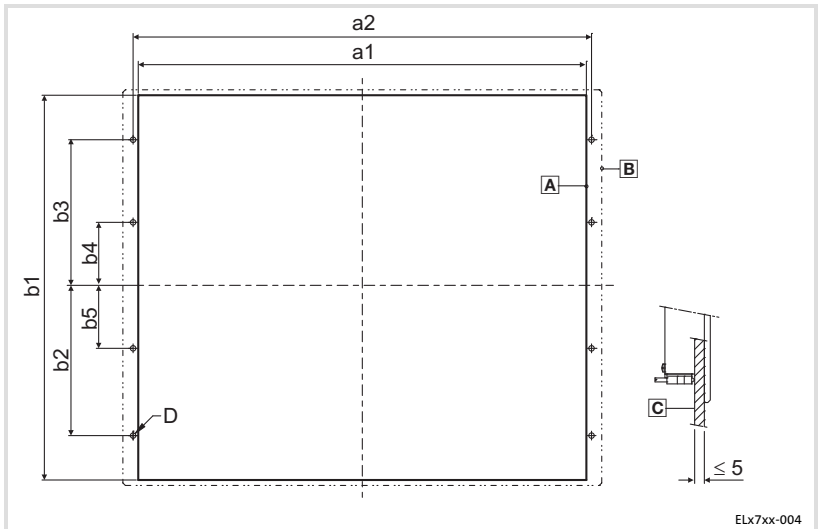

- A** Apertura di montaggio
- B** Profilo del telaio frontale
- C** Quadro elettrico

Tutte le quote sono in millimetri.

Dimensioni								
	a1	a2	b1	b2	b3	b4	b5	D
	[mm]							
EL 1800	305.0	-	228.0	-	-	-	-	-
EL 1800s								
EL 1850	343.0	-	228.0	-	-	-	-	-
EL 1850s								
EL 2800	340.0	351.0	288.0	122.0	122.0	0.0	-	6 x \varnothing 5.5
EL 2850	375.0	386.0	288.0	122.0	122.0	0.0	-	
EL 5800	400.0	411.0	313.0	134.5	134.5	0.0	-	
EL 5820	452.0	462.4	299.0	104.9	104.6	15.7	-	
EL 5850								
EL 5870	452.0	462.4	388.2	149.3	149.3	15.9	-	
EL 9800	438.0	451.0	386.0	172.0	172.0	60.0	60.0	8 x \varnothing 4.5

4 Installazione

Procedura di montaggio
Panel PC EL 1800(s) / EL 1850(s)

4.4 Procedura di montaggio

4.4.1 Panel PC EL 1800(s) / EL 1850(s)

Per il montaggio, procedere come segue:

1. Tagliare l'apertura di montaggio nel quadro elettrico (☐ 73).
2. Controllare che la guarnizione sotto la piastra frontale sia posizionata correttamente.
3. Collocare l'apparecchio nell'apertura di montaggio e tenerlo fermo con la mano per evitare che cada.
4. Montare tutti i serravite come segue:

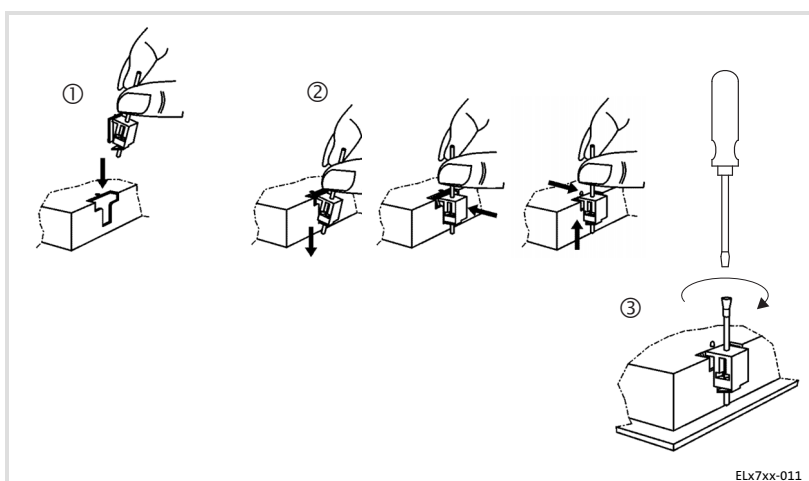

- Inserire il serravite nell'apertura sulla custodia dell'apparecchio, come mostrato in figura.
 - Premere il serravite verso il basso, inclinarlo verso la custodia e verificare che sia scattato correttamente in posizione.
 - Stringere bene il serravite con un cacciavite.
5. Controllare che l'apparecchio sia posizionato saldamente nell'apertura di montaggio e che la guarnizione della piastra frontale sia collocata correttamente.
 - Se necessario, riallineare l'apparecchio o la guarnizione.
 - Se la guarnizione non è posizionata correttamente, sul lato frontale dell'apparecchio non viene raggiunta la classe di protezione IP65!

4.4.2 Panel PC EL 2800 / EL 2850 / EL 5800 / EL 5820 / EL 5850 / EL 5870 / EL 9800

Montaggio su quadro elettrico

Per il montaggio, procedere come segue:

1. Tagliare l'apertura di montaggio nel quadro e realizzare i fori di fissaggio nel quadro (☞ 73).
2. Controllare che la guarnizione sotto la piastra frontale sia posizionata correttamente.
3. Collocare l'apparecchio nell'apertura di montaggio e tenerlo fermo con la mano per evitare che cada e avvitare i dadi con rondelle ai perni filettati.
4. Montare tutti i serravite come segue:

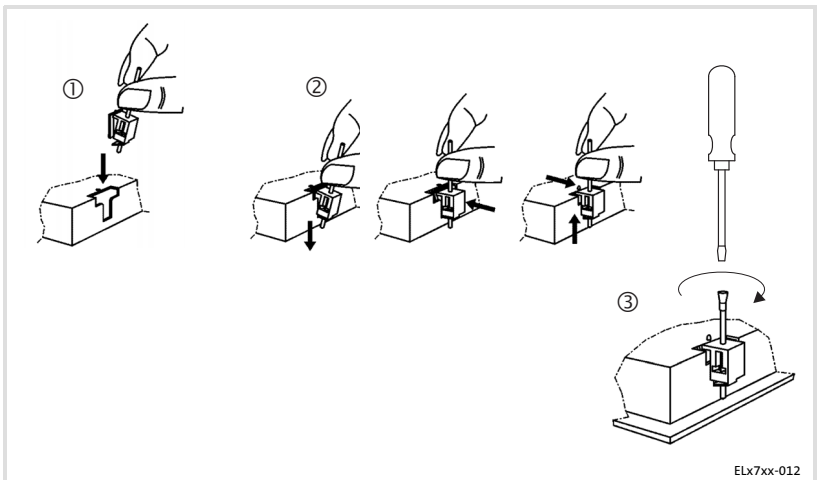

ELx7xx-012

- Inserire il serravite nell'apertura sulla custodia dell'apparecchio, come mostrato in figura.
 - Premere il serravite verso il basso, inclinarlo verso la custodia e verificare che sia scattato correttamente in posizione.
 - Stringere bene il serravite con un cacciavite.
5. Controllare che l'apparecchio sia posizionato saldamente nell'apertura di montaggio e che la guarnizione della piastra frontale sia collocata correttamente.
 - Se necessario, riallineare l'apparecchio o la guarnizione.
 - Se la guarnizione non è posizionata correttamente, sul lato frontale dell'apparecchio non viene raggiunta la classe di protezione IP65!

Installazione in rack di montaggio da 19" (solo EL 5820, EL 5850 e EL 5870)

Per il montaggio, procedere come segue:

1. Rimuovere dal telaio frontale le spina filettate posteriori.
2. Sul telaio frontale, eseguire i fori ciechi posteriori con una punta di trapano da 6.5 mm.
3. Posizionare l'apparecchio nel rack di montaggio da 19" e avvitarlo bene.

4.5 Installazione elettrica

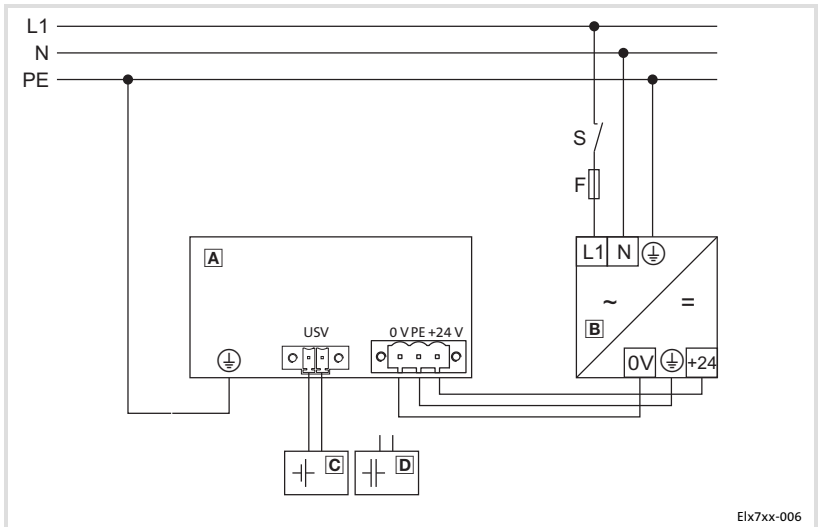

- A** IPC
- B** Alimentatore
- C** Gruppo batterie (opzionale)
- D** Gruppo condensatore (opzionale)



© 04/2013

Lenze Automation GmbH
Hans-Lenze-Str. 1
D-31855 Aerzen
Germany



+49 (0)51 54 / 82-0



+49 (0)51 54 / 82 - 28 00



Lenze@Lenze.de



www.Lenze.com



Service

Lenze Service GmbH
Breslauer Straße 3
D-32699 Extertal
Germany



00 80 00 / 24 4 68 77 (24 h helpline)



+49 (0)51 54 / 82-11 12



Service@Lenze.de

MA_ELx8xx ■ 13434909 ■ DE/EN/FR/ES/IT ■ 1.3 ■ TD29

10 9 8 7 6 5 4 3 2 1