

NZM1-XT(V)(R)(-60)
NZM2-XT(V)(R)(-60)

1a NZM1...

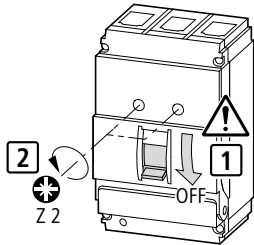

2a

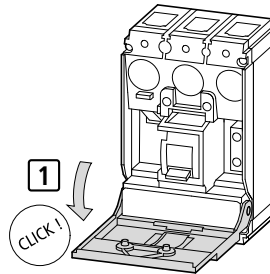

1b NZM2...

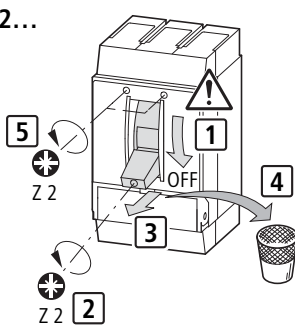

2b

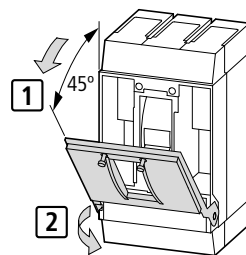

3

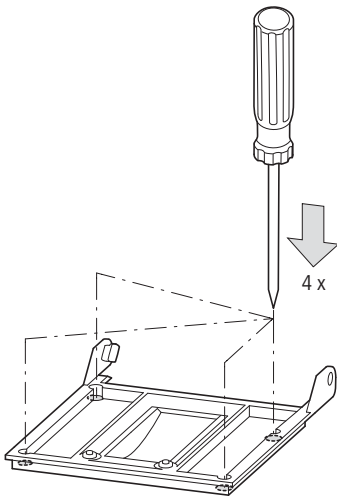

4

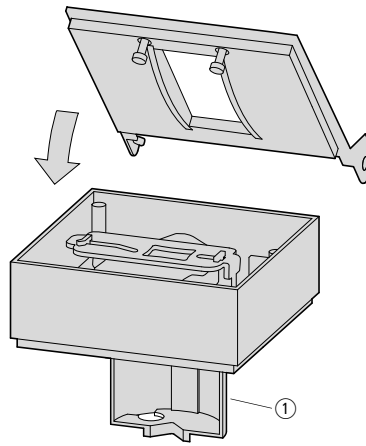

5

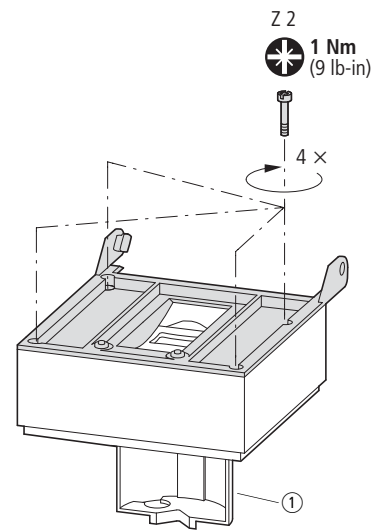

6a

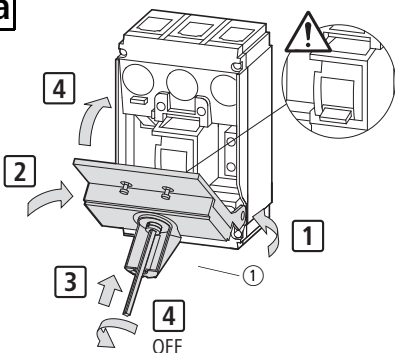

6b

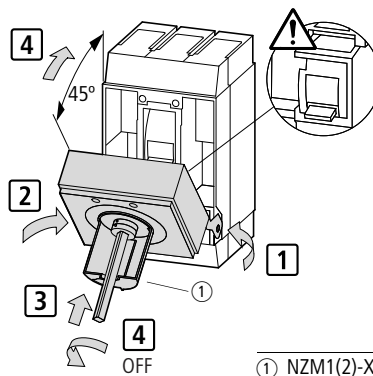

7

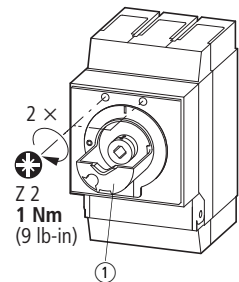

⚡ (en) Electric current! Danger to life!

Only skilled or instructed persons may carry out the following operations.

(de) Lebensgefahr durch elektrischen Strom!
Nur Elektrofachkräfte und elektrotechnisch unterwiesene Personen dürfen die im Folgenden beschriebenen Arbeiten ausführen.

(fr) Tension électrique dangereuse !
Seules les personnes qualifiées et averties doivent exécuter les travaux ci-après.

(es) ¡Corriente eléctrica! ¡Peligro de muerte!
El trabajo a continuación descrito debe ser realizado por personas cualificadas y advertidas.

(it) Tensione elettrica: Pericolo di morte!
Solo persone abilitate e qualificate possono eseguire le operazioni di seguito riportate.

(zh) 触电危险!
只允许专业人员和受过专业训练的人员进行下列工作。

(ru) Электрический ток! Опасно для жизни!
Только специалисты или проинструктированные лица могут выполнять следующие операции.

① NZM1(2)-XT...-60 always without shaft support
NZM1(2)-XT...-60 ist immer ohne Achs-Abstützung
NZM1(2)-XT...-60 toujours sans support d'axe
NZM1(2)-XT...-60 nunca posee soporte del eje
NZM1(2)-XT...-60 è sempre senza supporto asse
NZM1(2)-XT...-60 总是没有轴支承。
NZM1(2)-XT...-60 всегда без опоры на ось

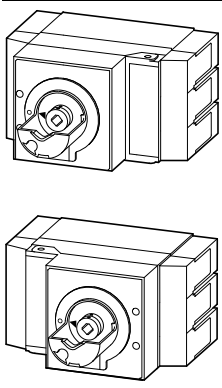

1

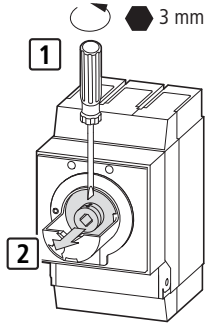

2a

NZM1(2)-XT(V)D(V)(R)

3 × Z1

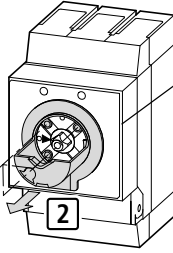

2b

NZM1(2)-XT(V)D(V)(R)-60

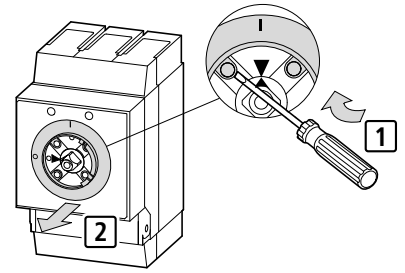

NZM1(2)-XT(V)D(V)(R)

3a

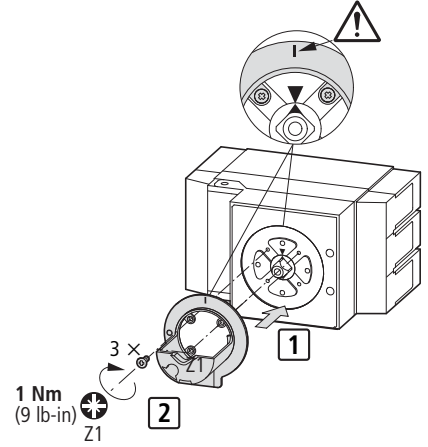
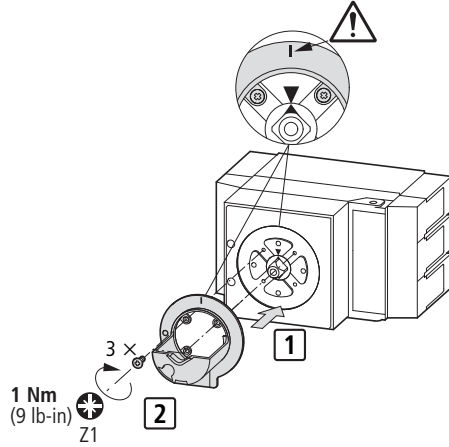

NZM1(2)-XT(V)D(V)(R)-60

3b

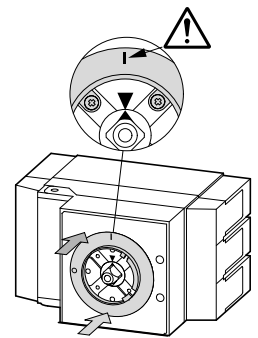
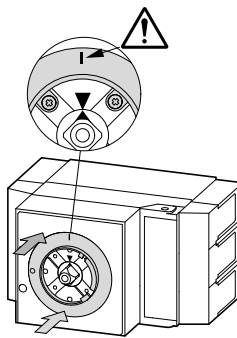

4

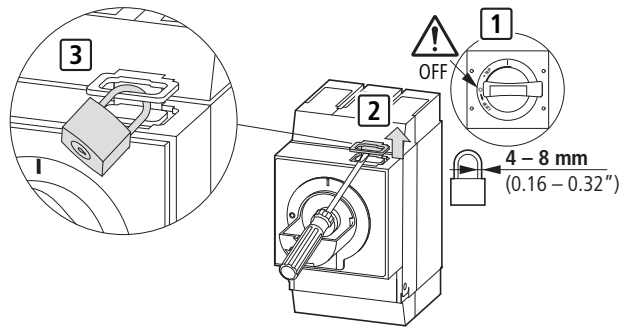
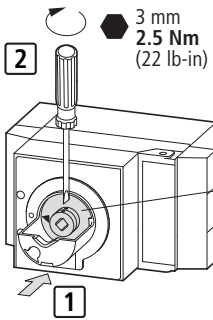

NZM1(2)-XTVD(V)(R)(60)

1

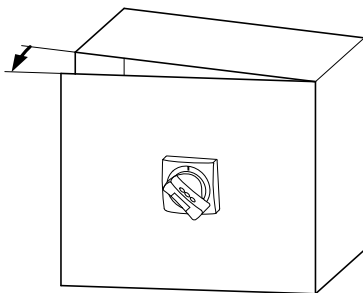
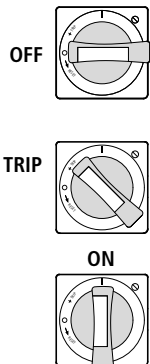

2

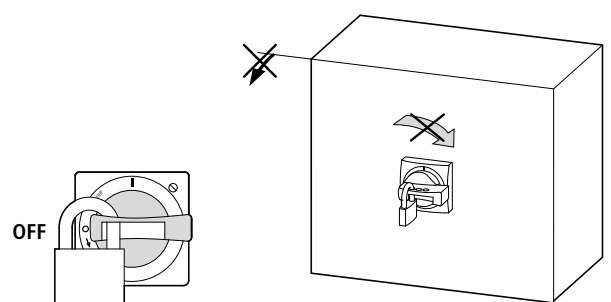

11/10 IL01203005Z

NZM1(2)-XTVD(V)(R)(60)-NA

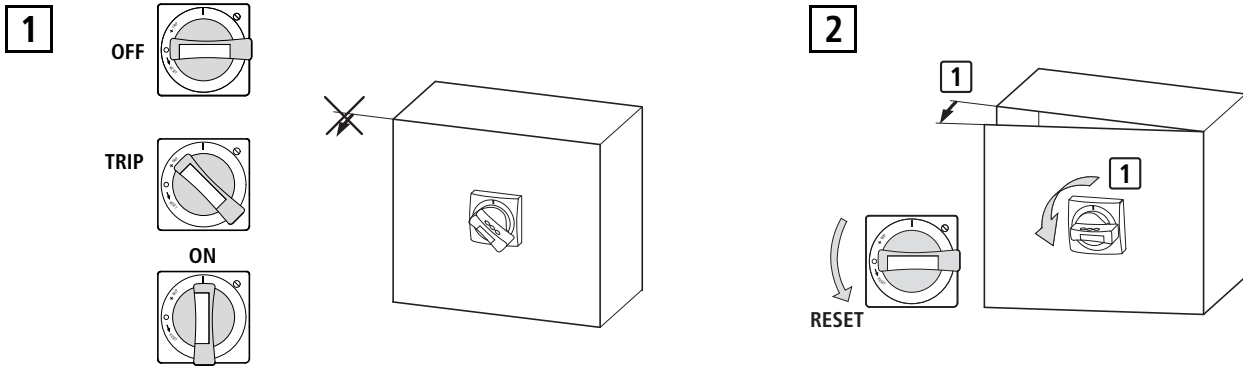

NZM1(2)-XTVD NZM1(2)-XTVD(V)(R)

Activation of the door interlock
 Aktivierung der Türverriegelung
 Activation du verrouillage de porte
 Activación del enclavamiento de puerta
 Attivazione del bloccoporta
 激活门锁
 Активирование блокировки дверей

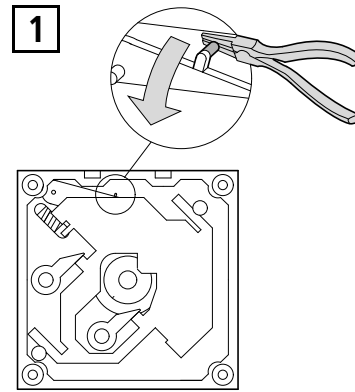

11/10 IL01203005Z

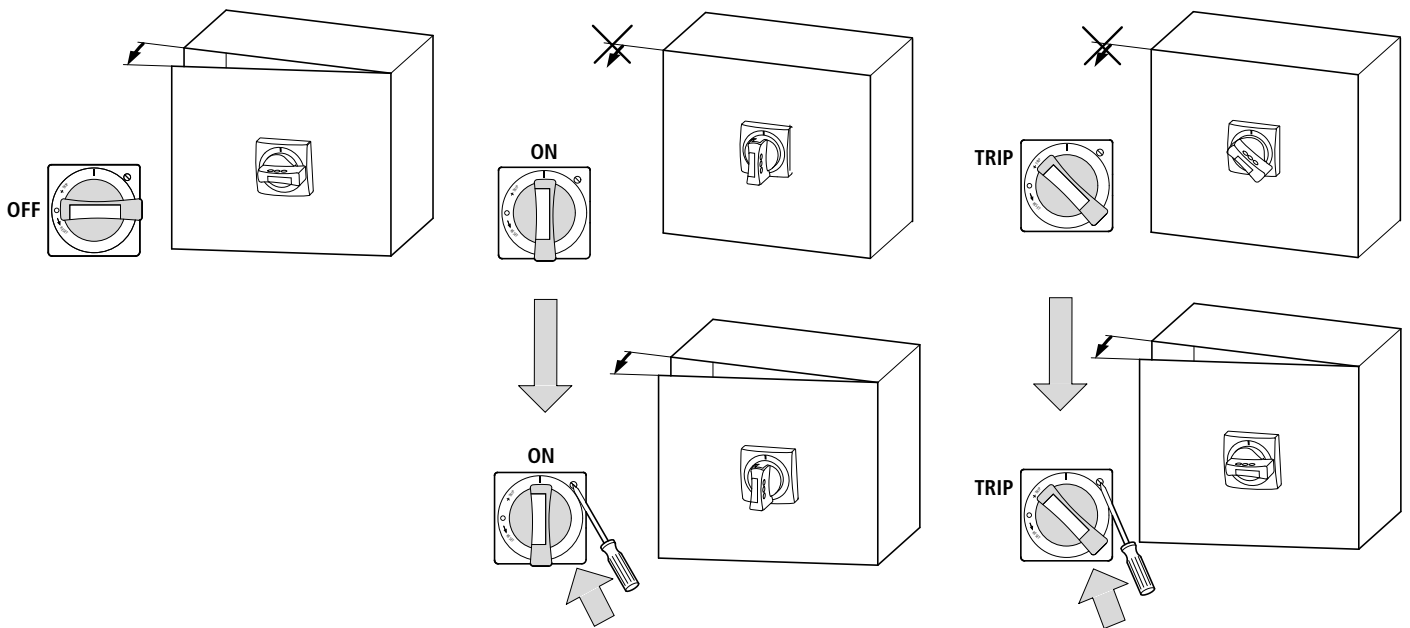

NZM1(2)-XTVD(V)

Activation of the locking position in ON position – Aktivierung der Abschließposition in ON-Stellung – Activation de la position de verrouillage en ON – Activación de la posición enclavable en posición ON – Attivazione della lucchettatura nella posizione ON – 在 ON 位置上激活锁止位置 – Активирование запирающей позиции в положении ON

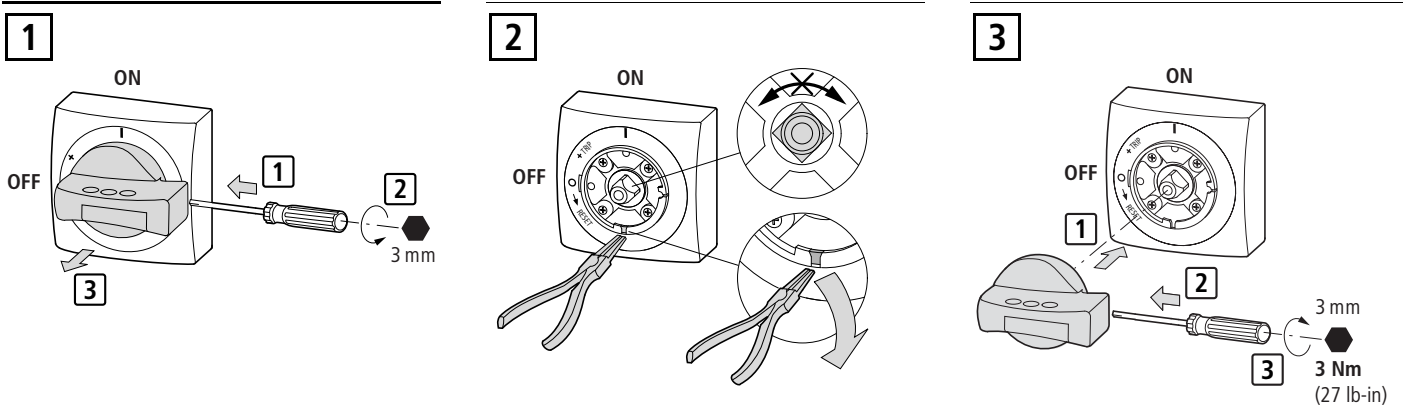

4 TEST

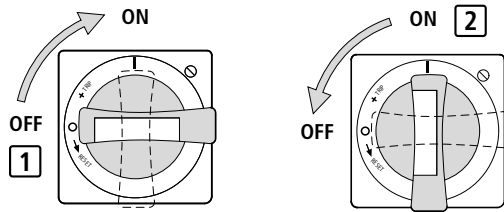

NZM1(2)-XTVDVR



(en) Warning!
It is not permitted to activate the locking position in ON position for the emergency-stop!

(de) Warnung!
Es ist nicht zulässig, die Abschließposition in ON-Stellung für den NOT-AUS zu aktivieren!

(fr) Avertissement !
Il est interdit d'activer la position de verrouillage en ON pour l'arrêt d'urgence !

(es) ¡Precaución!
¡No está permitido activar la posición enclavable en la posición ON en el pulsador de paro de emergencia!

(it) Avvertenza!
Non è permesso lucchettare nella posizione ON la maniglia a comando rinviato per arresto di emergenza!

(zh) 警告 !
不允许紧急停止情况下在 ON 位置上激活锁止位置

(ru) Предупреждение!
Активировать запирающую позицию в положении ON для аварийного отключения не разрешается!

5

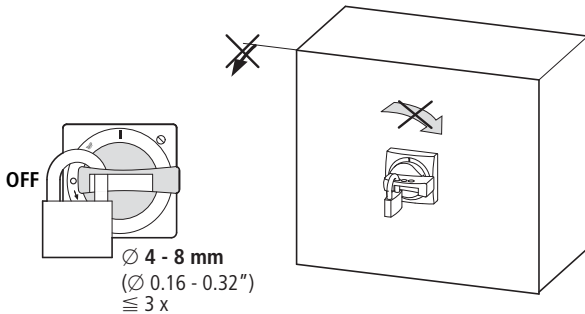

6

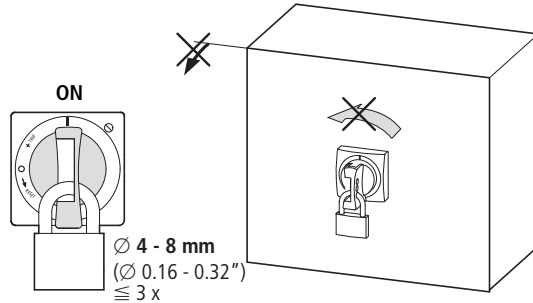

Mounting – Montage – Montaje – Montaggio – 安装 – Монтаж

1

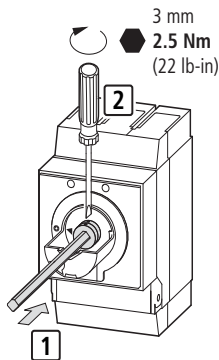

2

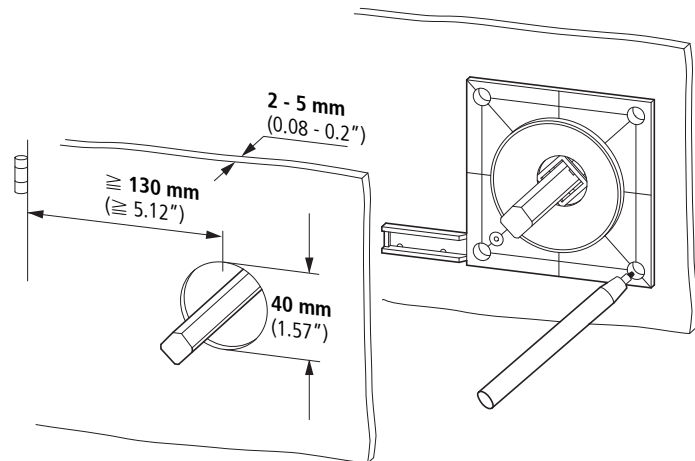

3

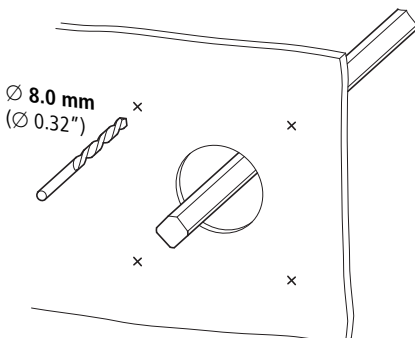

4

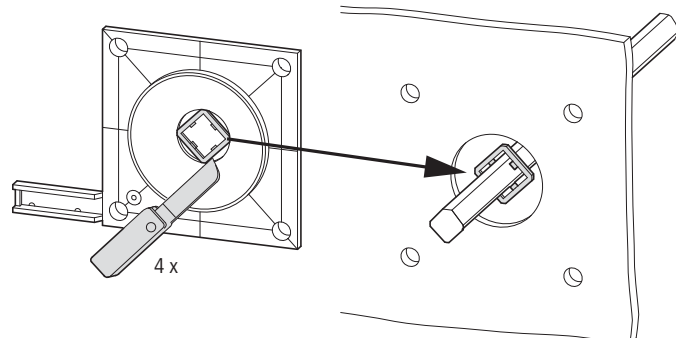

11/10 IL01203005Z

Einklappseite: 17 mm Beschnitt

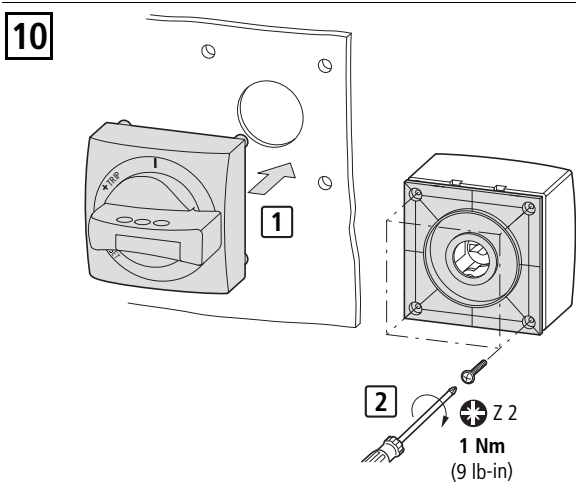
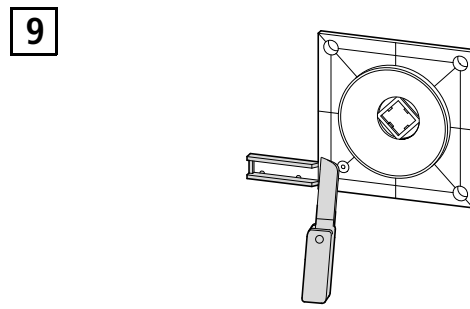
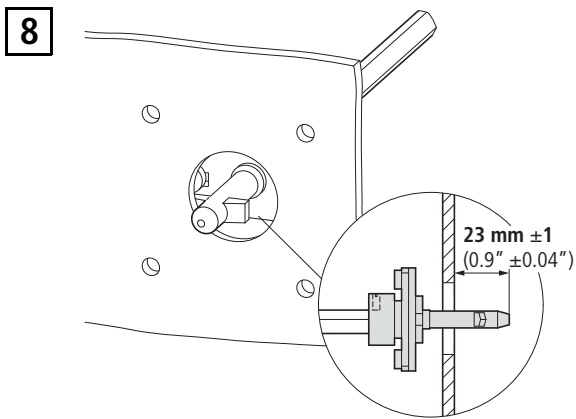
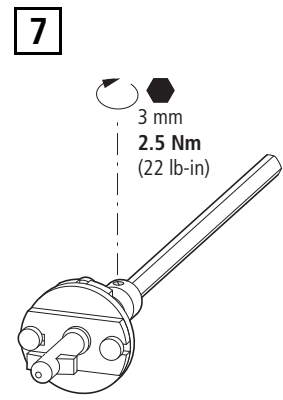
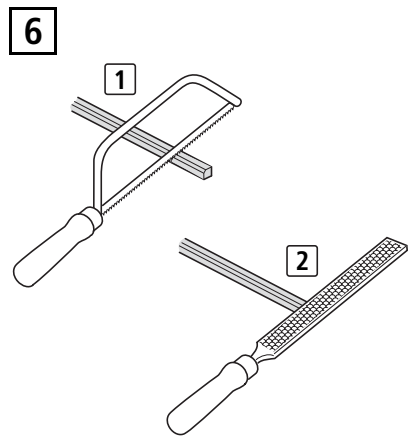
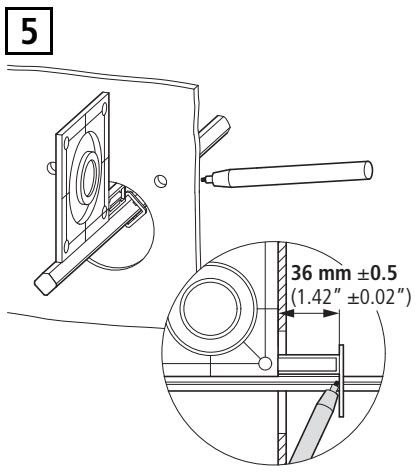

Dismounting – Demontage – Démontage – Smontaggio –
Desmontaje – 拆卸 – Демонтаж

