

## SIRIUS

### Sperrglied für Wendeschalter S0, S2, S3

3RA1924-2B

### Mechanical Interlock for Reversing Contactor S0, S2, S3

### Element de verrouillage pour Contacteurs-inverseurs S0, S2, S3

### Bloqueo mecánico para contactores-inversores S0, S2, S3

### Elemento di blocco per contattore-invertitore S0, S2, S3

### Elemento supressor para interruptor inversor S0, S2, S3



IEC/EN 60947

Montageanleitung/Assembly Instructions

Bestell-Nr./Order No.: 3ZX1012-0RA02-1AA1

	<b>⚠️ WARNUNG</b> Gefährliche elektrische Spannung! Kann zu elektrischem Schlag und Verbrennungen führen. Vor Beginn der Arbeiten Anlage und Gerät spannungsfrei schalten.	<b>⚠️ WARNING</b> HAZARDOUS VOLTAGE. Can cause electrical shock and burns. Disconnect power before proceeding with any work on this equipment.	<b>⚠️ ATTENTION</b> Tension dangereuse ! Risque d'électrocution et de brûlure. Isoler cet appareil du réseau avant d'y intervenir pour travaux.
	<b>⚠️ ADVERTENCIA</b> ¡Tensión peligrosa! Puede causar choque eléctrico y quemaduras. Desconectar la alimentación antes de efectuar trabajo alguno en este equipo.	<b>⚠️ ATTENZIONE</b> Tensione elettrica pericolosa! Rischio di shock elettrico e ustioni. Prima di eseguire qualsiasi tipo di lavoro, assicurarsi che l'apparecchio e l'impianto siano scollegati.	<b>⚠️ AVISO</b> Tensão elétrica perigosa! Pode causar um choque elétrico e queimaduras. Antes de iniciar os trabalhos, desligue a tensão da unidade e do aparelho.

Eine sichere Gerätefunktion ist nur mit zertifizierten Komponenten gewährleistet.

Reliable functioning of the equipment is only ensured with certified components.

Le fonctionnement sûr de l'appareil n'est garanti qu'avec des composants certifiés.

El funcionamiento seguro del aparato sólo está garantizado con componentes certificados.

Il funzionamento sicuro dell'apparecchiatura viene garantito soltanto con componenti certificati.

O funcionamento seguro do aparelho apenas pode ser garantido se forem utilizados os componentes certificados.

### 3RT102 + 3RA1924-2B

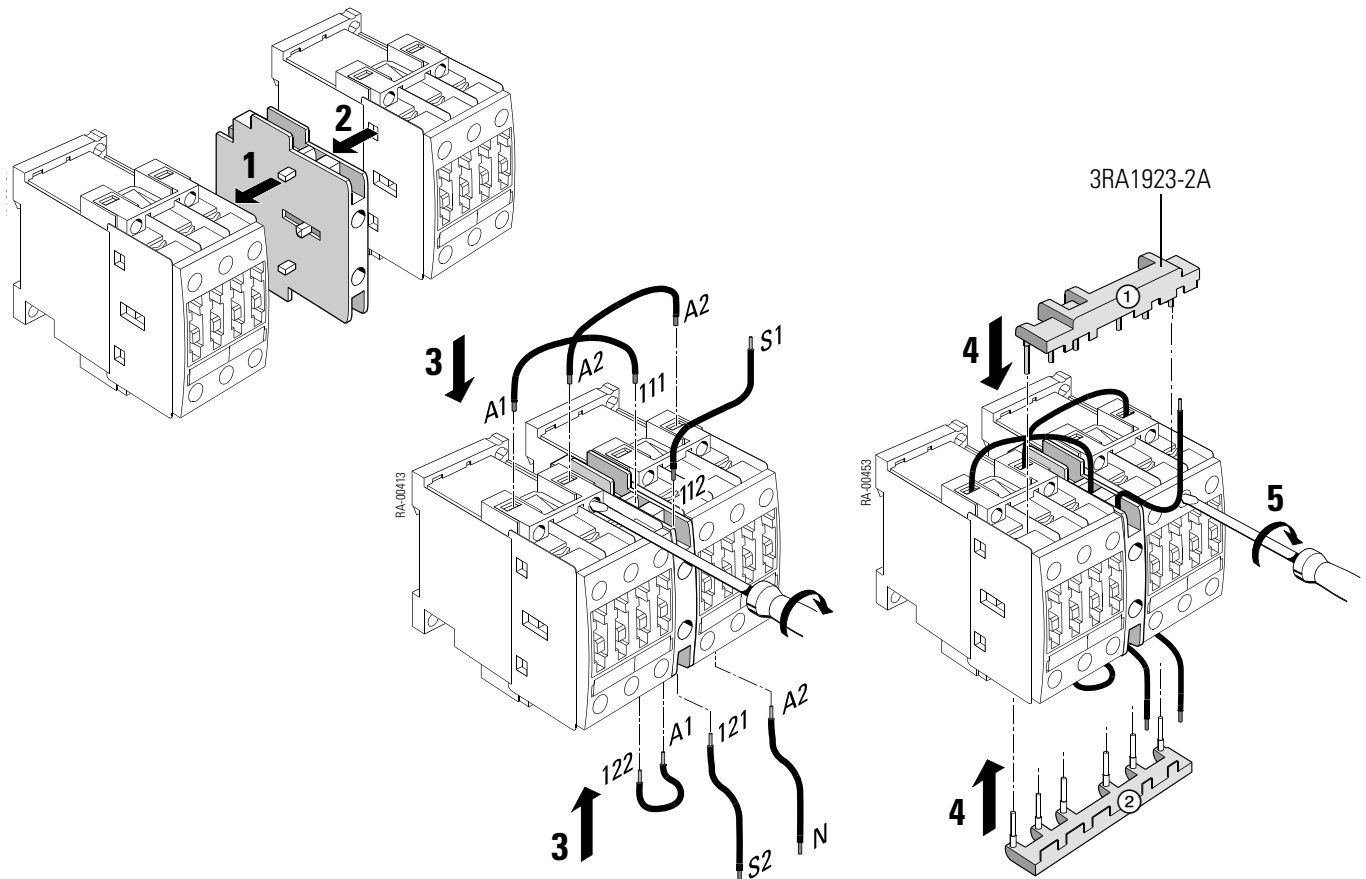

**3RT103/RT104 + 3RA1924-2B**

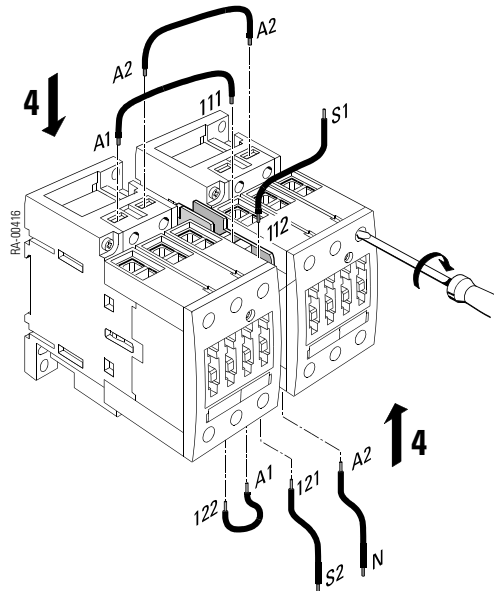
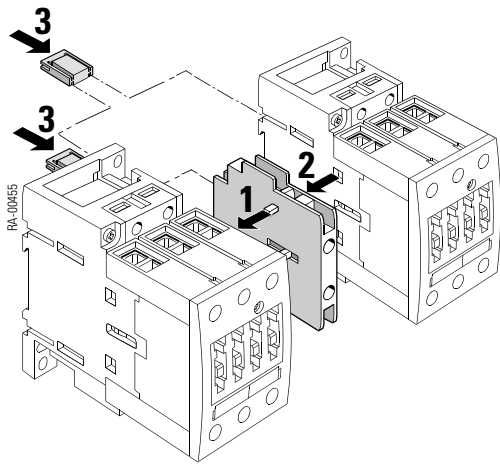

**3RT103/RT104 + 3RA1924-2B**

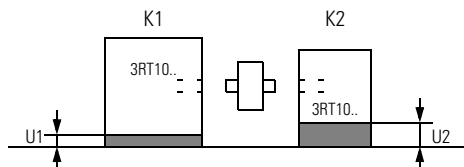
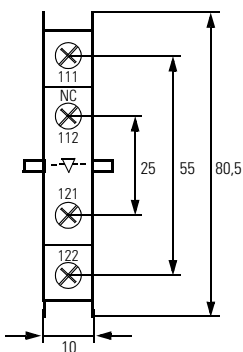
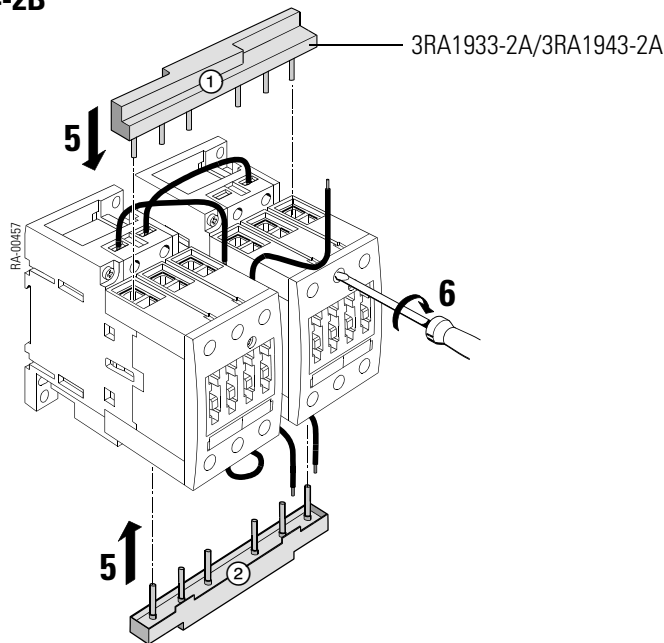

	K1	K2	U1	U2
1.	3RT104.-A AC	3RT103.-A AC	- 0 -	27,5
2.	3RT104.-B DC	3RT103.-B DC	- 0 -	24,5
3.	3RT103.-A AC	3RT102.-A AC	1,5	- 0 -
4.	3RT103.-B DC	3RT102.-B DC	- 0 -	3,5

**Technical Assistance:** Telephone: +49 (0) 9131-7-43833 (8<sup>00</sup> - 17<sup>00</sup> CET) Fax: +49 (0) 9131-7-42899  
 E-mail: [technical-assistance@siemens.com](mailto:technical-assistance@siemens.com)  
 Internet: [www.siemens.de/lowvoltage/technical-assistance](http://www.siemens.de/lowvoltage/technical-assistance)

**Technical Support:** Telephone: +49 (0) 180 50 50 222