

SIEMENS

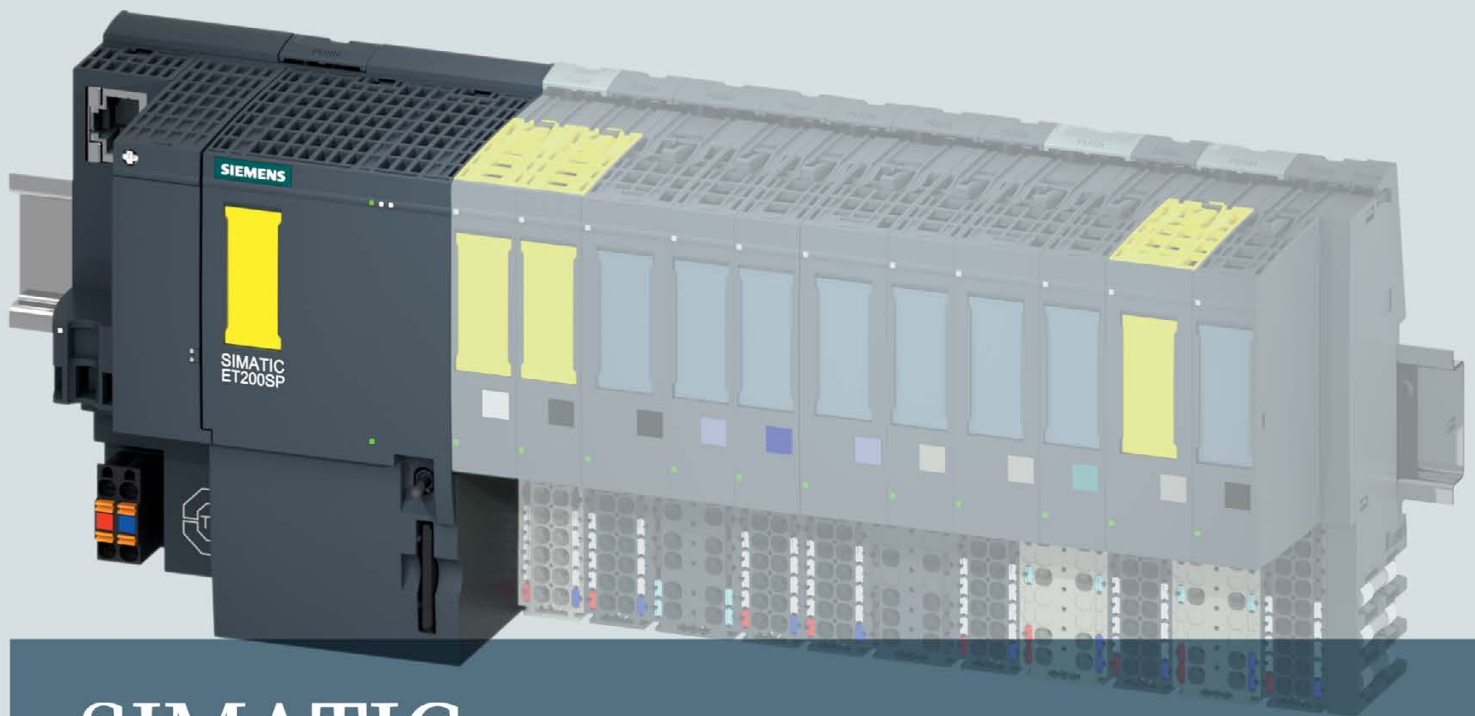

SIMATIC

ET 200SP

CPU 1512SP F-1 PN (6ES7512-1SK00-0AB0)

Manual

Edition

12/2014

Answers for industry.

SIEMENS

SIMATIC

ET 200SP
CPU 1512SP F-1 PN
(6ES7512-1SK00-0AB0)

Manual

Preface

Documentation guide

1

Product overview

2

Wiring

3

Interrupts, error messages,
diagnostics and system
alarms

4

Technical specifications

5



Dimension drawing

A

Legal information

Warning notice system

This manual contains notices you have to observe in order to ensure your personal safety, as well as to prevent damage to property. The notices referring to your personal safety are highlighted in the manual by a safety alert symbol, notices referring only to property damage have no safety alert symbol. These notices shown below are graded according to the degree of danger.

 DANGER
indicates that death or severe personal injury will result if proper precautions are not taken.
 WARNING
indicates that death or severe personal injury may result if proper precautions are not taken.
 CAUTION
indicates that minor personal injury can result if proper precautions are not taken.
NOTICE
indicates that property damage can result if proper precautions are not taken.

If more than one degree of danger is present, the warning notice representing the highest degree of danger will be used. A notice warning of injury to persons with a safety alert symbol may also include a warning relating to property damage.

Qualified Personnel

The product/system described in this documentation may be operated only by **personnel qualified** for the specific task in accordance with the relevant documentation, in particular its warning notices and safety instructions. Qualified personnel are those who, based on their training and experience, are capable of identifying risks and avoiding potential hazards when working with these products/systems.

Proper use of Siemens products

Note the following:

 WARNING
Siemens products may only be used for the applications described in the catalog and in the relevant technical documentation. If products and components from other manufacturers are used, these must be recommended or approved by Siemens. Proper transport, storage, installation, assembly, commissioning, operation and maintenance are required to ensure that the products operate safely and without any problems. The permissible ambient conditions must be complied with. The information in the relevant documentation must be observed.

Trademarks

All names identified by ® are registered trademarks of Siemens AG. The remaining trademarks in this publication may be trademarks whose use by third parties for their own purposes could violate the rights of the owner.

Disclaimer of Liability

We have reviewed the contents of this publication to ensure consistency with the hardware and software described. Since variance cannot be precluded entirely, we cannot guarantee full consistency. However, the information in this publication is reviewed regularly and any necessary corrections are included in subsequent editions.

Preface

Purpose of the documentation

This manual supplements the ET 200SP distributed I/O system (<http://support.automation.siemens.com/WW/view/en/58649293>) system manual as well as the function manuals. All system-wide functions are described in the system manual and in the function manuals.

The information provided in this manual and the system manual allows you to commission the CPU 1512SP F-1 PN.

The creation of the safety program and activation of safety operation are described in the configuration and programming manual SIMATIC Safety - Configuring and Programming (<http://support.automation.siemens.com/WW/view/en/54110126>).

Conventions

STEP 7: In this documentation, "STEP 7" is used as a synonym for all versions of the configuration and programming software "STEP 7 (TIA Portal)".

When this device manual refers to the CPU 1512SP-1 PN, we are actually referring to the CPU 1512SP F-1 PN.

Please also observe the notes marked as follows:

Note

A note contains important information on the product described in the documentation, on handling the product or on the part of the documentation to which particular attention should be paid.

Security information

Siemens provides products and solutions with industrial security functions that support the secure operation of plants, solutions, machines, equipment and/or networks. They are important components in a holistic industrial security concept. With this in mind, Siemens' products and solutions undergo continuous development. Siemens recommends strongly that you regularly check for product updates.

For the secure operation of Siemens products and solutions, it is necessary to take suitable preventive action (e.g. cell protection concept) and integrate each component into a holistic, state-of-the-art industrial security concept. Third-party products that may be in use should also be considered. You can find more information about industrial security on the Internet (<http://www.siemens.com/industrialsecurity>).

To stay informed about product updates as they occur, sign up for a product-specific newsletter. You can find more information on the Internet (<http://support.automation.siemens.com>).

Table of contents

	Preface	4
1	Documentation guide	6
2	Product overview	8
2.1	Operating principle	8
2.2	Properties	9
2.3	Differences between F-CPU 1512SP F-1 PN and standard CPU 1512SP F-1 PN	12
2.4	Operating and display elements	14
2.4.1	Front view of the module with BusAdapter	14
2.5	Mode switch	15
2.6	Functions	15
2.6.1	PROFINET IO	15
2.6.2	PROFenergy	16
2.6.3	PROFIBUS DP	17
2.6.4	Memory reset	18
2.6.5	Restoring the factory settings of the CPU	19
3	Wiring	22
4	Interrupts, error messages, diagnostics and system alarms	27
4.1	Status and error display of the CPU	27
5	Technical specifications	30
5.1	Technical specifications	30
A	Dimension drawing	40

Documentation guide

The documentation for the SIMATIC ET 200SP distributed I/O system is arranged into three areas.

This arrangement enables you to access the specific content you require.

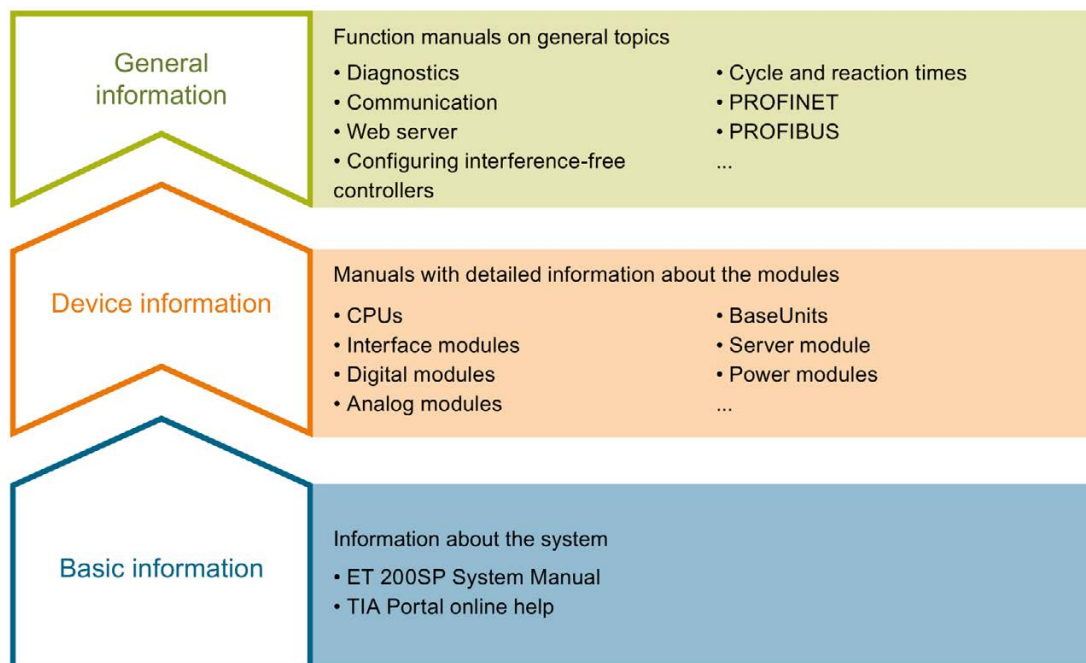

Basic information

The system manual describes in detail the configuration, installation, wiring and commissioning of the SIMATIC ET 200SP. distributed I/O system. The STEP 7 online help supports you in the configuration and programming.

Device information

Product manuals contain a compact description of the module-specific information, such as properties, terminal diagrams, characteristics and technical specifications.

General information

The function manuals contain detailed descriptions on general topics regarding the SIMATIC ET 200SP distributed I/O system, e.g. diagnostics, communication, Web server, designing interference-free controllers.

You can download the documentation free of charge from the Internet (<http://w3.siemens.com/mcms/industrial-automation-systems-simatic/en/manual-overview/tech-doc-et200/Pages/Default.aspx>).

Changes and supplements to the manuals are documented in a Product Information.

Manual Collection ET 200SP

The Manual Collection contains the complete documentation on the SIMATIC ET 200SP distributed I/O system gathered together in one file.

You can find the Manual Collection on the Internet (<http://support.automation.siemens.com/WW/view/en/84133942>).

My Documentation Manager

The My Documentation Manager is used to combine entire manuals or only parts of these to your own manual.

You can export the manual as PDF file or in a format that can be edited later.

You can find the My Documentation Manager on the Internet (<http://support.automation.siemens.com/WW/view/en/38715968>).

Applications & Tools

Applications & Tools supports you with various tools and examples for solving your automation tasks. Solutions are shown in interplay with multiple components in the system - separated from the focus in individual products.

You can find Applications & Tools on the Internet (<http://support.automation.siemens.com/WW/view/en/20208582>).

CAX Download Manager

The CAX Download Manager is used to access the current product data for your CAX or CAe systems.

You configure your own download package with a few clicks.

In doing so you can select:

- Product images, 2D dimension drawings, 3D models, internal circuit diagrams, EPLAN macro files
- Manuals, characteristics, operating manuals, certificates
- Product master data

You can find the CAX Download Manager on the Internet (<http://support.automation.siemens.com/WW/view/en/42455541>).

TIA Selection Tool

With the TIA Selection Tool, you can select, configure and order devices for Totally Integrated Automation (TIA).

This tool is the successor of the SIMATIC Selection Tool and combines the known configurators for automation technology into one tool.

With the TIA Selection Tool, you can generate a complete order list from your product selection or product configuration.

You can find the TIA Selection Tool on the Internet (<http://w3.siemens.com/mcms/topics/en/simatic/tia-selection-tool>).

Product overview

2.1 Operating principle

The CPU includes the operating system and executes the user program. The user program is located on the SIMATIC memory card and is processed in the CPU work memory.

The PROFINET interfaces available on the CPU enable simultaneous communication with PROFINET devices, PROFINET controllers, HMI devices, programming devices, other controllers and additional systems. The CPU 1512SP-1 PN supports operation as an IO controller, I-device or standalone CPU.

With its optional PROFIBUS interface, CM DP, CPU 1512SP-1 PN supports the configuration of PROFIBUS networks in addition to PROFINET IO. When you use the interface as a PROFIBUS DP interface, you can configure the CPU 1512SP-1 PN as a DP master or as an intelligent DP slave (I-slave).

IO controller

CPU 1512SP-1 PN sends and receives data from the connected IO devices within a PROFINET IO system. You can operate the CPU with a maximum of 128 connected IO devices, a maximum of 64 of which use IRT (Isochronous Realtime).

I-device

The "I-device" (intelligent IO device) functionality allows you to exchange data with an IO controller. CPU 1512SP-1 PN thus fulfills the role of an intelligent distributed pre-processing unit for sub-processes. The I-device is connected as an IO device to a higher-level IO controller for this purpose.

Advantages:

- Interference-resistant configuration due to short signal and encoder wiring
- Reduced wiring requirements for transmission of the data via PROFINET

Standalone CPU

You can also use the CPU 1512SP-1 PN in the ET 200SP distributed I/O system as a "central system" without a higher-level controller.

DP master

To use the ET 200SP as a DP master, you need the CPU and the optional communication module, CM DP. When used as a DP master, ET 200SP exchanges data with the connected DP slaves via PROFIBUS DP.

Intelligent DP slave (I-slave)

To use the ET 200SP as an intelligent DP slave (I-slave), you need the CPU and the optional communication module, CM DP. As an I-slave, ET 200SP is connected via PROFIBUS DP to the higher-level DP master and exchanges data with it.

2.2 Properties

Article number

6ES7512-1SK00-0AB0

View of the module

The following figure shows the CPU 1512SP F-1 PN.

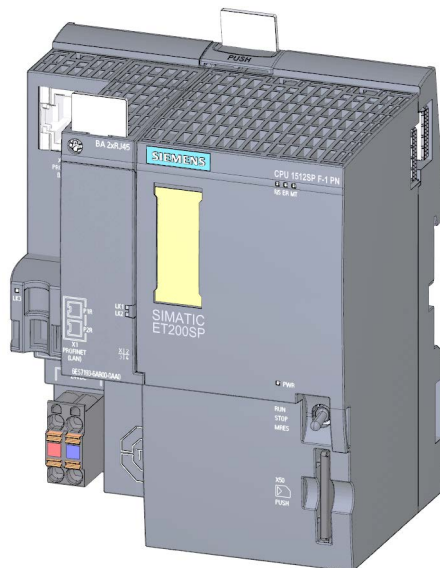

Figure 2-1 CPU 1512SP F-1 PN

Properties

The CPU 1512SP F-1 PN has the following technical properties:

- Communication:

- Interfaces

The CPU 1512SP F-1 PN has a PROFINET interface (X1) with an integrated 3-port switch. Port 1 and port 2 are located on the pluggable BusAdapter. Port 3 is integrated in the housing of the CPU. The CPU supports the BusAdapters BA 2xRJ45 and BA 2xFC. You connect the PROFINET IO to the CPU via the BusAdapter. Port 1 and port 2 can also be used as ring ports for the configuration of redundant ring structures in Ethernet (media redundancy).

Note

The CPU is delivered without a BusAdapter. You can find the article numbers of the supported BusAdapters in the "Accessories/spare parts" section of the ET 200SP Distributed I/O system

(<http://support.automation.siemens.com/WW/view/en/58649293>) system manual.

The PROFINET interface supports PROFINET IO RT (Realtime) and IRT (Isochronous Realtime) in addition to PROFINET basic functionality. PROFINET IO communication or real-time settings can be configured on the interface.

The CM DP is optionally available with a PROFIBUS interface (X2). You can find more information about this expansion module in the manual CM DP communication module (<http://support.automation.siemens.com/WW/view/en/90156526>).

You can find information about connecting the PROFINET IO BusAdapter to the CPU as well as connecting the optional PROFIBUS interface to the interface module in the system manual ET 200SP distributed I/O system

(<http://support.automation.siemens.com/WW/view/en/58649293>).

- Integrated Web server:

The CPU is accessible via an integrated Web server for diagnostic purposes. You can read the following information with the Web server:

- Start page with general CPU information
 - Identification information
 - Contents of the diagnostics buffer
 - Querying module information
 - Alarms (without acknowledgment option)
 - Information about communication
 - PROFINET topology
 - Tag status
 - Watch tables
 - Memory usage
 - Data logs (if used)

- Integrated technology:
 - Motion Control
PLC-Open blocks for programming motion functionality via PROFINET IO IRT with PROFIdrive interface.
The functionality supports speed-controlled axes, positioning axes, synchronous axes and external encoders.
 - Integrated closed-loop control functionality
 - Universal PID controller and 3-point controller with integrated tuning
 - Integrated temperature controller
- Trace functionality:
 - Trace functionality supports you in troubleshooting and optimizing the user program, especially for motion control or closed-loop control applications.
- Integrated system diagnostics:
 - The alarms for the system diagnostics are automatically created by the system and displayed on a PG/PC, HMI device or the Web server. System diagnostics information is also available when the CPU is in STOP mode.
- Integrated security:
 - Know-how protection
The assignment of passwords protects user blocks against unauthorized access and modifications.
 - Copy protection
Copy protection links user blocks to the serial number of the SIMATIC memory card or to the serial number of the CPU. User programs cannot run without the corresponding SIMATIC memory card or CPU.
 - Access protection
Extended access protection provides high-quality protection against unauthorized configuration changes. You can use authorization levels to assign separate rights to different user groups.
 - Integrity protection
The system protects the data transferred to the CPU against manipulation. The CPU detects erroneous or manipulated engineering data.

You can find additional information on the topic of "Protection" in the system manual ET 200SP distributed I/O system (<http://support.automation.siemens.com/WW/view/en/58649293>).
- The CPU 1512SP F-1 PN supports the following functions:
 - Safety mode
 - Firmware update
 - PROFIenergy
 - Shared device
 - Configuration control
 - Isochronous mode

2.3 Differences between F-CPU 1512SP F-1 PN and standard CPU 1512SP F-1 PN

Areas of application

CPU 1512SP F-1 PN is mainly used for the protection of personnel and machinery and burner controls. In addition to the safety program, you can also program standard applications.

Table 2- 1 Areas of application

You intend to use CPU 1512SP F-1 PN for	then you require
Safety-related applications	STEP 7 Professional V13 SP1 or higher Optional package STEP 7 Safety Advanced V13 SP1 or higher
Standard applications	STEP 7 Professional V13 SP1 or higher

PFD, PFH values for S7-1500 F-CPUs

Below you will find the probability of failure values (PFD_{avg}, PFH values) for S7-1500 F-CPUs with a service life of 20 years and with a repair time of 100 hours:

Operation in low demand mode low demand mode According to IEC 61508:2010: PFD _{avg} = Average probability of a dangerous failure on demand	Operation in high demand or continuous mode high demand/continuous mode According to IEC 61508:2010: PFH = Average frequency of a dangerous failure [h ⁻¹]
< 2E-05	< 1E-09

Restriction with "CREAT_DB" and "DELETE_DB"

F-DBs can neither be created nor deleted.

Restriction with "READ_DBL" and "WRIT_DBL"

The destination address must not point to an F-DB.

Restrictions when configuring the retentive behavior of data blocks

The configuration of the retentive behavior of data blocks is not supported for F-DBs.

This means that the actual values of the F-DBs will not be retentive in the event of Power OFF/ON and Restart (STOP-RUN) of the F-CPU. The F-DBs retain the initial values from the load memory.

The "Retain" check box is grayed-out for all tags in F-DBs.

Web server

CPU 1512SP F-1 PN shows you the following on the start page of the web server:

- Safety mode activated/deactivated
- Collective signature
- Last fail-safe change
- Version of STEP 7 Safety with which the safety program was compiled.

The following is displayed for each F-I/O on the "Module information" web page in the "Fail-safe" tab:

- F-parameter signature (with address)
- Safety mode
- F-monitoring time
- F-source address
- F-destination address

Write access to F-blocks is not permitted.

2.4 Operating and display elements

2.4.1 Front view of the module with BusAdapter

The figure on the left shows the CPU 1512SP-1 PN including a plugged BA 2xRJ45 BusAdapter. The figure on the right shows a separate view of the BA 2xRJ45 BusAdapter.

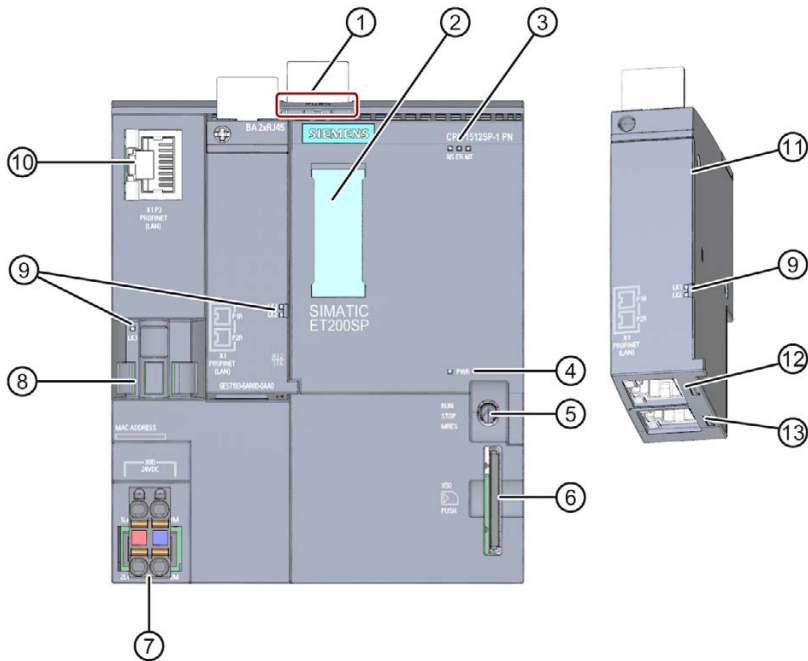

- ① Mounting rail release
- ② Labeling strips
- ③ LEDs for status and error displays
- ④ LED for display of the supply voltage
- ⑤ Mode switch
- ⑥ Slot for the SIMATIC memory card
- ⑦ Connection for supply voltage (included in product package)
- ⑧ Cable support and attachment for port P3 of the PROFINET interface
- ⑨ LEDs for status displays of the PROFINET interface: LK1 and LK2 on BusAdapter, LK3 on CPU
- ⑩ Port P3 of the PROFINET interface: RJ45 socket
- ⑪ Separate view of the BusAdapter
- ⑫ Port P1 R of the PROFINET interface: RJ45 socket on BusAdapter BA 2xRJ45
R: Ring port for configuring a ring topology with media redundancy
- ⑬ Port P2 R of the PROFINET interface: RJ45 socket on BusAdapter BA 2xRJ45
R: Ring port for configuring a ring topology with media redundancy

Figure 2-2 Front view of the CPU 1512SP-1 PN with BusAdapter

2.5 Mode switch

Use the mode switch to set the CPU operating mode.

The following table shows the position of the switch and the corresponding meaning.

Table 2- 2 Mode switch settings

Position	Meaning	Explanation
RUN	RUN mode	The CPU is executing the user program.
STOP	STOP mode	The user program is not being executed.
MRES	Memory reset	Position for CPU memory reset.

2.6 Functions

2.6.1 PROFINET IO

PROFINET is a fieldbus standard of the PROFIBUS user organization that defines a cross-vendor communications and engineering model.

As part of PROFINET, PROFINET IO is a communication concept that is used to implement modular, distributed applications. PROFINET IO IRT allows defined response times and highly precise plant behavior.

A PROFINET IO system consists of the following PROFINET devices:

- IO controller
Device used to address the connected IO devices.
- IO device
A distributed field device that is assigned to an IO controller.

The PROFINET IO controller operating mode allows direct access to IO devices via Industrial Ethernet (for example from an S7-1500 CPU as IO controller to a CPU 1512SP-1 PN as IO device).

With the PROFINET IO device operating mode, you can operate the CPU 1512SP-1 PN as an "intelligent" PROFINET IO device on Industrial Ethernet.

Note

The BusAdapter BA 2xRJ45 (6ES7193-6AR00-0AA) or BusAdapter BA 2xFC (6ES7193-6AF00-0AA0) is required for standard-compliant operation of the CPU 1512SP-1 PN (6ES7512-1DK00-0AB0) as PROFINET IO controller and PROFINET IO device.

General properties of PROFINET IO

PROFINET IO provides the following properties and functions:

- Real-time communication (RT)
- Isochronous real-time communication (IRT)
- Media redundancy
- Prioritized startup
- Device replacement without exchangeable medium
- I-device
- IO controller
- Shared device
- Isochronous mode

Reference

You can find additional information on the "PROFINET IO" topic in the STEP 7 online help and in the PROFINET System Description (<http://support.automation.siemens.com/WW/view/en/19292127>) manual.

2.6.2 PROFIenergy

PROFIenergy

PROFIenergy is a PROFINET-based data interface for switching off consumers centrally and with full coordination during pause times regardless of the manufacturer or device type. Through this, the process should only be provided with the energy that is absolutely required. The majority of the energy is saved by the process; the PROFINET device itself only contributes a few watts of savings potential.

Additional information

- See the PROFINET (<http://support.automation.siemens.com/WW/view/en/68039307>) function manual
- You will find more information on PROFIenergy in the PROFINET specification on the Internet (<http://www.profibus.com>).

2.6.3 PROFIBUS DP

With its optional PROFIBUS interface, CM DP, CPU 1512SP-1 PN supports the configuration of PROFIBUS networks in addition to PROFINET IO.

PROFIBUS is the fieldbus network for the cell and field level. Physically, PROFIBUS is an electrical network based on a shielded two-wire cable or an optical network based on a fiber optic cable.

Data transfer via PROFIBUS DP provides a standardized interface (EN 50170 Vol. 2) for the transfer of process input and process output data between a DP master and field devices (DP slaves).

The transmission behavior via PROFIBUS DP is characterized by cyclical data exchange between the DP master and the DP slaves.

A DP system based on the PROFIBUS DP standard (IEC 61158 Type 3) consists of the following devices:

- DP master

A device of this function class handles the actual control task.

The device sends and receives process input and process output signals.

- DP slave

This is a device in the field area which reads or outputs the process signals. The devices can be modular or compact.

Using the optional CM DP module, the CPU 1512SP-1 PN can be configured as a DP master or as an intelligent DP slave (I-slave). The DP interface enables a transmission rate of up to 12 Mbps.

When in master mode, the CPU sends its configured bus parameters on the PROFIBUS DP interface. This means, for example, that a programming device can obtain the correct parameters so that you can go online with the PG without any further settings. Transmission of the bus parameters can be activated/deactivated in the configuration. As default, the CPU sends the bus parameters.

Properties of the PROFIBUS DP interface of the CM DP module

The PROFIBUS DP interface of the optional CM DP module has the following properties and functions:

- PROFIBUS DP master
- I-slave
- Time-of-day synchronization
- Line diagnostics
- S7 services

Reference

You will find additional information on "PROFIBUS DP" in the STEP 7 online help and in the PROFIBUS with STEP 7 (<http://support.automation.siemens.com/WW/view/en/59193579>) function manual.

2.6.4 Memory reset

Apart from a few exceptions, a "memory reset" involves clearing all internal memories and then reading in the data on the SIMATIC memory card.

Options

You have the following options for resetting the memory of the CPU:

- Using the mode selector
- Using STEP 7

Procedure using the mode selector

To perform a memory reset of the CPU using the mode selector, follow these steps:

1. Set the mode selector to STOP.
Result: The RUN/STOP LED lights up yellow.
2. Set the mode selector to the MRES position. Hold the switch in this position until the RUN/STOP LED lights up yellow for the 2nd time and remains lit (this takes three seconds). After this, release the switch.
3. Within the next three seconds, return the mode selector to the MRES position, and then back to STOP.

Result: The CPU performs a memory reset. During the memory reset, the RUN/STOP LED flashes yellow. The RUN/STOP LED lights yellow when the CPU has completed the memory reset.

Procedure using STEP 7

To perform a memory reset of the CPU via STEP 7, follow these steps:

1. Open the "Online tools" task card of the CPU.
2. Click the "MRES" button in the "CPU operator panel" pane.
3. Click "OK" to confirm the security prompt.

Result: The CPU is in STOP mode and performs a memory reset.

Response of the memory objects to the memory reset

The following table provides an overview of which memory objects are retained and which are initialized in the case of a memory reset.

Table 2- 3 Retentive characteristics of the memory objects

Memory object	Contents
Actual values of the data blocks, instance data blocks	Initialized
Bit memories, timers and counters	Initialized
Retentive tags of technology objects (for example, calibration values of absolute encoders)*	Retained
Diagnostics buffer entries (retentive area)	Retained
Diagnostics buffer entries (non-retentive area)	Initialized
IP address	Retained
Counter readings of the operating hours counters	Retained
Time	Retained

* The retentive tags of technology objects are retained, but the contents of certain tags are partially re-initialized.

Reference

You can find additional information on the topic of "Memory reset" in the system manual ET 200SP distributed I/O system (<http://support.automation.siemens.com/WW/view/en/58649293>).

2.6.5 Restoring the factory settings of the CPU

The CPU can be reset to its factory state using "Reset to factory settings". The function deletes all information that was stored internally on the CPU.

Note

If you want to remove a PROFINET CPU and use it elsewhere with a different program or put it into storage, we recommend that you reset the CPU to its factory settings. Remember that the Reset to factory settings function also deletes the IP address parameters.

Options

You have the following options for returning the CPU to the factory settings:

- Using the mode selector
- Using STEP 7

Procedure using the mode selector

Make sure that there is no SIMATIC memory card in the CPU and that the CPU is in STOP mode (RUN/STOP LED lights up yellow).

Reset to the factory settings as follows:

1. Set the mode selector to STOP.

Intermediate result: The RUN/STOP LED lights up yellow.

2. Set the mode selector to the MRES position. Hold the mode selector in this position until the RUN/STOP LED lights up yellow for the 2nd time and remains lit (this takes three seconds). After this, release the switch.
3. Within the next three seconds, return the mode selector to the MRES position, and then back to STOP.

Result: The CPU executes a reset to factory settings, during which time the RUN/STOP LED flashes yellow. The RUN/STOP LED lit yellow indicates that the CPU has been reset to the factory settings and is in STOP mode. The "Reset to factory settings" event is entered in the diagnostics buffer.

Procedure using STEP 7

Make sure that there is an online connection to the CPU.

1. Open the online and diagnostics view of the CPU.
2. In the "Functions" folder, select the "Reset to factory settings" group.
3. Select the option button "Retain IP address" if you want to keep the IP address. Select the option button "Delete IP address" if you want to delete the IP address.
4. Click "Reset".
5. Click "OK" to confirm the security prompt.

Result: The CPU goes into STOP mode and is reset to factory settings.

Behavior of the memory objects with a reset to factory settings

The properties of the CPU are set to the following values:

Table 2- 4 Properties of CPU objects in the factory settings

Memory object	Contents
Actual values of the data blocks, instance data blocks	Initialized
Bit memories, timers and counters	Initialized
Certain retentive tags of technology objects (for example, calibration values of absolute encoders)	Initialized
Diagnostics buffer entries (retentive area)	Initialized
Diagnostics buffer entries (non-retentive area)	Initialized
IP address	Depending on the procedure: <ul style="list-style-type: none"> Using the mode selector: it is deleted Using STEP 7: depends on the setting for the option boxes "Retain IP address"/"Delete IP address"
Counter readings of the operating hours counters	Initialized
Time	Initialized

Reference

You can find additional information on the topic of "Reset to factory settings" in the system manual ET 200SP distributed I/O system (<http://support.automation.siemens.com/WW/view/en/58649293>) and in the online help for STEP 7.

This section provides information on the pin assignment of the individual interfaces and the block diagram of the CPU 1512SP-1 PN.

24 V DC supply voltage (X80)

The connector for the supply voltage is plugged in when the CPU ships from the factory.

The following figure shows the pin assignment for a 24 V DC supply voltage.

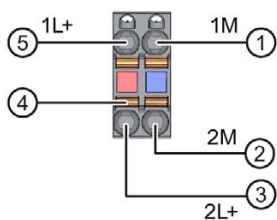

- ① Ground of the supply voltage
- ② Ground of the supply voltage for loop-through (permitted value 10 A)
- ③ + 24 V DC of the supply voltage for loop-through (permitted value 10 A)
- ④ Spring NC contacts
- ⑤ + 24 V DC of the supply voltage

Internally jumpered:

- ① and ②
- ③ and ⑤

Figure 3-1 Supply voltage connection

PROFINET IO interface on the CPU (X1 P3)

The table below shows the pin assignment of the PROFINET IO interface integrated in the CPU. The assignment corresponds to the Ethernet standard for an RJ45 plug.

Table 3- 1 Pin assignment PROFINET IO interface on the CPU

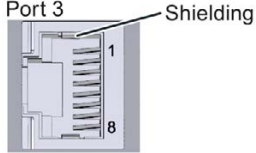
View	Signal name		Designation
	1	TD	Transmit data +
	2	TD_N	Transmit data -
	3	RD	Receive data +
	4	GND	Ground
	5	GND	Ground
	6	RD_N	Receive data -
	7	GND	Ground
	8	GND	Ground

PROFINET IO interface on the BA 2xRJ45 BusAdapter (X1 P1 R and X1 P2 R)

The table below shows the pin assignment of the PROFINET IO interface on the BA 2xRJ45 BusAdapter. The assignment corresponds to the Ethernet standard for an RJ45 plug.

Table 3- 2 Pin assignment PROFINET IO interface on the BA 2xRJ45 BusAdapter

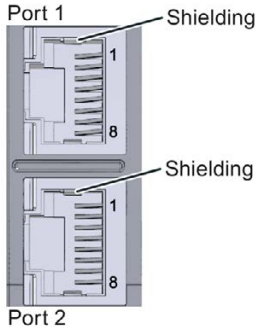
View	Signal name		Designation
	1	TD	Transmit data +
	2	TD_N	Transmit data -
	3	RD	Receive data +
	4	GND	Ground
	5	GND	Ground
	6	RD_N	Receive data -
	7	GND	Ground
	8	GND	Ground

PROFINET IO interface on the BA 2xFC BusAdapter (X1 P1 R and X1 P2 R)

The table below shows the pin assignment of the PROFINET IO interface on the BA 2xFC BusAdapter.

Table 3- 3 Pin assignment PROFINET IO interface on the BA 2xFC BusAdapter

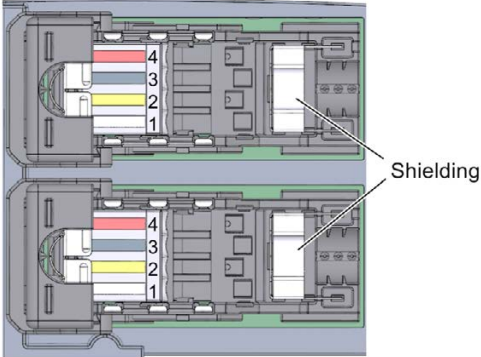
View	Signal name		Designation
 <p>Port 1</p> <p>Port 2</p> <p>Shielding</p>	1	TD	Transmit data +
	2	TD_N	Transmit data -
	3	RD	Receive data +
	4	RD_N	Receive data -

Reference

You can find additional information on the topics of "Connecting the CPU" and "Accessories/spare parts" in the system manual ET 200SP distributed I/O system (<http://support.automation.siemens.com/WW/view/en/58649293>).

Assignment of the MAC addresses

The MAC address is a globally unique device identifier that is assigned to each PROFINET device in the factory. Its 6 bytes are divided into 3 bytes for the manufacturer ID and 3 bytes for the device ID (serial number). The front of the CPU 1512SP-1 PN is lasered with the MAC address of the PROFINET interface.

The PROFINET interface (X1) of the CPU 1512SP-1 PN has three ports. Port 3 is located on the CPU. Ports 1 and 2 are located on the optional BusAdapter. In addition to the PROFINET interface, each PROFINET port also has a separate MAC address. There is therefore a total of four MAC addresses for the CPU 1512SP-1 PN.

The MAC addresses of the PROFINET ports are needed for the LLDP protocol, for example for the neighborhood discovery function.

The table below shows how the MAC addresses are assigned.

Table 3- 4 Assignment of the MAC addresses

	Assignment
MAC address 1	PROFINET interface X1 <ul style="list-style-type: none"> • Visible in STEP 7 for accessible devices • Lasered on the front of the CPU (start of the number range)
MAC address 2	Port X1 P1 R (required for LLDP, for example)
MAC address 3	Port X1 P2 R (required for LLDP, for example)
MAC address 4	Port X1 P3 (required for LLDP, for example)

Block diagram

The following figure shows the block diagram of the CPU 1512SP-1 PN.

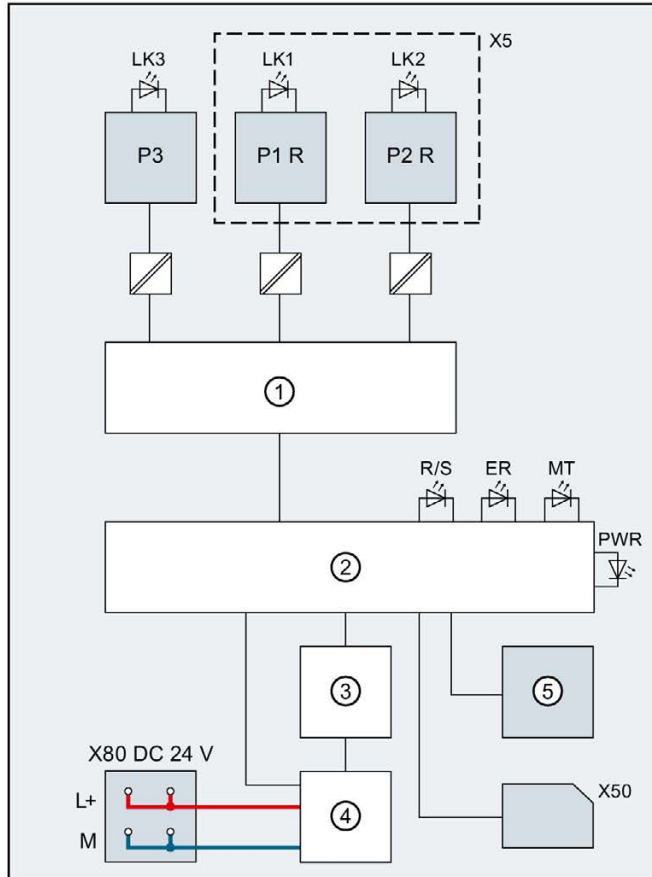

①	Switch	P1 R	PROFINET interface X1 Port 1
②	Electronics	P2 R	PROFINET interface X1 Port 2
③	Backplane bus interface	P3	PROFINET interface X1 Port 3
④	Internal supply voltage	L+	24 V DC supply voltage
⑤	RUN/STOP/MRES mode selector	M	Ground
X5	BusAdapter	LK1, 2, 3	LED Link TX/RX
X50	SIMATIC memory card	R/S	RUN/STOP LED (yellow/green)
X80 24 V DC	Infeed of supply voltage	ER	ERROR LED (red)
		MT	MAINT LED (yellow)
		PWR	POWER LED (green)

Figure 3-2 Block diagram of the CPU 1512SP-1 PN

Interrupts, error messages, diagnostics and system alarms

4

The status and error displays of the CPU 1512SP-1 PN are described below.

You will find additional information on "Interrupts" in the STEP 7 online help.

You can find additional information on the topics of "Diagnostics" and "System alarms" in the Diagnostics (<http://support.automation.siemens.com/WW/view/en/59192926>) function manual.

4.1 Status and error display of the CPU

LED displays

The figure below shows the LED displays of the CPU 1512SP-1 PN and the BA 2xRJ45 BusAdapter.

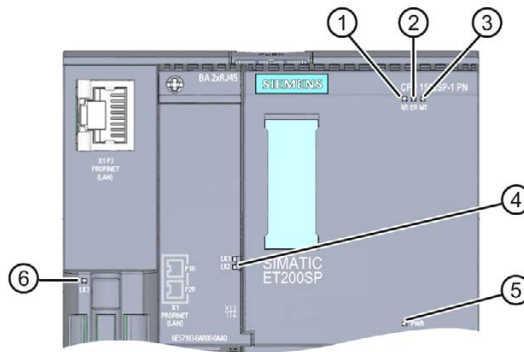

- ① RUN/STOP LED (yellow/green LED)
- ② ERROR LED (red LED)
- ③ MAINT LED (yellow LED)
- ④ LINK RX/TX LED for ports X1 P1 and X1 P2 (green LEDs on BusAdapter)
- ⑤ POWER LED (green LED)
- ⑥ LINK RX/TX LED for port X1 P3 (green LED on CPU)

















































Figure 4-1 LED displays on the CPU and BusAdapter

4.1 Status and error display of the CPU

Meaning of the LED displays

CPU 1512SP-1 PN features an LED for monitoring the supply voltage of the electronics (PWR) and three LEDs for displaying the current operating and diagnostics status. The following table shows the meaning of the various combinations of colors for the POWER, RUN/STOP, ERROR and MAINT LEDs.



Table 4- 1 Meaning of the LEDs

POWER LED	RUN/STOP LED	ERROR LED	MAINT LED	Meaning
 LED off	 LED off	 LED off	 LED off	Missing or insufficient supply voltage on the CPU.
 LED lit green	 LED off	 LED flashes red	 LED off	An error has occurred.
 LED lit green	 LED lit green	 LED off	 LED off	CPU is in RUN mode.
 LED lit green	 LED lit green	 LED flashes red	 LED off	A diagnostics event is pending.
 LED lit green	 LED lit green	 LED off	 LED lit yellow	Maintenance demanded for the plant. The affected hardware must be checked/replaced within a short period of time.
				Active Force job
				PROFenergy pause
 LED lit green	 LED lit green	 LED off	 LED flashes yellow	Maintenance required for the plant. The affected hardware must be checked/replaced within a foreseeable period of time.
				Bad configuration
 LED lit green	 LED lit yellow	 LED off	 LED flashes yellow	Firmware update successfully completed.
 LED lit green	 LED lit yellow	 LED off	 LED off	CPU is in STOP mode.
 LED lit green	 LED lit yellow	 LED flashes red	 LED flashes yellow	The program on the SIMATIC memory card is causing an error.
				CPU defective
 LED lit green	 LED flashes yellow	 LED off	 LED off	CPU is performing internal activities during STOP, e.g. startup after STOP.
				Download of the user program from the SIMATIC memory card
 LED lit green	 LED flashes yellow/green	 LED off	 LED off	Startup (transition from RUN → STOP)
 LED lit green	 LED flashes yellow/green	 LED flashes red	 LED flashes yellow	Startup (CPU booting)
				Test of LEDs during startup, inserting a module.
				LED flashing test

Meaning of the LEDs of the interfaces: X1 P1 R, X1 P2 R and X1 P3

Each port has a LINK LED (LK1, LK2, LK3). The table below shows the various "LED scenarios" of the ports of the CPU 1512SP-1 PN.

Table 4- 2 Meaning of the LED

LINK LED	Meaning
 LED off	There is no Ethernet connection between the PROFINET interface of the PROFINET device and the communication partner. No data is currently being sent/received via the PROFINET interface. There is no LINK connection.
 LED flashes green	The "LED flashing test" is being performed.
 LED lit green	There is an Ethernet connection between the PROFINET interface of your PROFINET device and a communication partner.

Technical specifications

5.1 Technical specifications

6ES7512-1SK00-0AB0	
Product type designation	CPU 1512SP F-1 PN
General information	
Hardware version	FS01
Firmware version	V1.7
Engineering with	
STEP 7 TIA Portal can be configured/integrated as of version	V13 SP1
Configuration control	
Via data record	Yes
Operator controls	
Mode selector	1
Supply voltage	
Type of supply voltage	24 V DC
Low limit of permissible range (DC)	19.2 V
High limit of permissible range (DC)	28.8 V
Reverse polarity protection	Yes
Power and voltage failure backup	
Power/voltage failure backup time	5 ms
Input current	
Power consumption (rated value)	0.6 A
Inrush current, max.	4.7 A; rated value
I^2t	0.14 A ² s
Power	
Incoming power to the backplane bus	8.75 W
Power loss	
Power loss, typ.	5.6 W
Memory	
Number of slots for SIMATIC memory card	1
SIMATIC memory card required	Yes
Work memory	
Integrated (for program)	300 KB
Integrated (for data)	1 MB
Load memory	
Plug-in (SIMATIC memory card), max.	32 GB

6ES7512-1SK00-0AB0	
Buffering	
Maintenance-free	Yes
CPU processing time	
For bit operations, typ.	48 ns
For word operations, typ.	58 ns
For fixed-point arithmetic, typ.	77 ns
For floating-point arithmetic, typ.	307 ns
CPU blocks	
Number of elements (total)	2000; elements can be taken to mean blocks such as DBs, FBs and FCs, as well as UDTs, global constants, etc.
DB	
Number range	1 to 65535
Size, max.	1 MB; the maximum size of the DB is 64 KB with non-tuned block access
FB	
Number range	1 to 65535
Size, max.	300 KB
FC	
Number range	1 to 65535
Size, max.	300 KB
OB	
Size, max.	300 KB
Number of free-cycle OBs	100
Number of time-of-day interrupt OBs	20
Number of time-delay interrupt OBs	20
Number of cyclic interrupt OBs	20; two RTG each with a "cyclic interrupt OB" or a "free-cycle OB" (F-OB) are additionally possible for fail-safe
Number of hardware interrupt OBs	50
Number of DPV1 interrupt OBs	3
Number of isochronous mode OBs	1
Number of technology synchronous interrupt OBs	2
Number of startup OBs	100
Number of asynchronous error OBs	4
Number of synchronous error OBs	2
Number of diagnostic interrupt OBs	1
Nesting depth	
Per priority class	24; up to 8 possible with F-blocks
Counters, timers and their retentivity	
S7 counters	
Number	2048
Retentivity	Yes
• Configurable	Yes

	6ES7512-1SK00-0AB0
IEC counters	
Number	Unlimited (only limited by work memory)
Retentivity	
• Configurable	Yes
S7 timers	
Number	2048
Retentivity	
• Configurable	Yes
IEC timers	
Number	Unlimited (only limited by work memory)
Retentivity	
• Configurable	Yes
Data areas and their retentivity	
Total retentive data area (including timers, counters, bit memories), max.	128 KB; for bit memories, timers, counters, DBs and technological data (axes), usable retentive memory: 88 KB
Bit memory	
Number, max.	16 KB
Number of clock memory bits	8; 8 clock memory bits, grouped in one clock memory byte
Data blocks	
Retentivity configurable	Yes
Retentivity preset	No
Local data	
Per priority class, max.	64 KB; max. 16 KB per block
Address area	
Number of IO modules	2048; max. number of modules/submodules
I/O address area	
Inputs	32 KB; all inputs located in the process image
Outputs	32 KB; all outputs located in the process image
Of which per integrated IO subsystem	
• Inputs (volume)	8 KB
• Outputs (volume)	8 KB
Of which per CM/CP	
• Inputs (volume)	8 KB
• Outputs (volume)	8 KB
Process image partitions	
Number of process image partitions, max.	32
Hardware configuration	
Number of hierarchical IO systems	2
Number of DP masters	
Via CM	1

6ES7512-1SK00-0AB0	
Number of IO controllers	
Integrated	1
Via CM	0
Rack	
Modules per rack, max.	64; CPU + 64 modules + server module (configuration width max. 1 m)
Rack, number of rows, max.	1
PtP CM	
Number of PtP CMs	The number of PtP CMs that can be connected is only limited by number of the available slots.
Time	
Clock	
Type	Hardware clock
Deviation per day, max.	10 s; typ.: 2 s
Buffering time	6 wk; at 40 °C ambient temperature, typ.
Operating hours counter	
Number	16
Time synchronization	
Supported	Yes
On DP, master	Yes; via CM DP module
On DP, slave	Yes; via CM DP module
In AS, master	Yes
In AS, slave	Yes
On Ethernet via NTP	Yes
Interfaces	
Number of PROFINET interfaces	1
Number of PROFIBUS interfaces	1; via CM DP module
1. interface	
Interface hardware	
• Number of ports	3
• Integrated switch	Yes
• RJ45 (Ethernet)	Yes; 1st integr. + 2. via BusAdapter BA 2x RJ45
Protocols	
• PROFINET IO controller	Yes
• PROFINET IO device	Yes
• SIMATIC communication	Yes
• Open IE communication	Yes
• Web server	Yes
• Media redundancy	Yes

6ES7512-1SK00-0AB0	
2. interface	
Interface hardware	
• Number of ports	1
• RS 485	Yes; via CM DP module
Protocols	
• SIMATIC communication	Yes
• PROFIBUS DP master	Yes
• PROFIBUS DP slave	Yes
Interface hardware	
RJ45 (Ethernet)	
100 Mbps	Yes
Autonegotiation	Yes
Autocrossing	Yes
Industrial Ethernet status LED	Yes
RS 485	
Transmission rate, max.	12 Mbps
Protocols	
Number of connections	
Number of connections, max.	88
Number of connections reserved for ES/HMI/Web	10
Number of connections via integrated interfaces	88
Number of S7 routing connections	16
PROFINET IO controller	
Services	
• PG/OP communication	Yes
• S7 routing	Yes
• Isochronous mode	Yes
• Open IE communication	Yes
• IRT	Yes
• MRP	Yes; as MRP redundancy manager and/or MRP client; max. number of devices in the ring: 50
• PROFINergy	Yes
• Prioritized startup	Yes; max. 32 PROFINET devices
• Number of connectable IO devices, max.	128; a total of up to 253 distributed I/O devices can be connected via PROFIBUS or PROFINET
• Of which IO devices with IRT and the "high performance" option, max.	64
• Number of IO devices for RT that can be connected, max.	128
• Of which are in line, max.	128

	6ES7512-1SK00-0AB0
<ul style="list-style-type: none"> • Number of IO devices that can be activated/deactivated simultaneously, max. 	8
<ul style="list-style-type: none"> • Number of IO devices per tool changer, max. 	8
<ul style="list-style-type: none"> • Update times 	Minimum value of update time also depends on the configured communication share for PROFINET IO, on the number of IO devices and the amount of configured user data.
With RT	
<ul style="list-style-type: none"> • With send clock of 250 µs 	250 µs to 128 ms
<ul style="list-style-type: none"> • With send clock of 500 µs 	500 µs to 256 ms
<ul style="list-style-type: none"> • With send clock of 1 ms 	1 ms to 512 ms
<ul style="list-style-type: none"> • With send clock of 2 ms 	2 ms to 512 ms
<ul style="list-style-type: none"> • With send clock of 4 ms 	4 ms to 512 ms
With IRT and the "high performance" option	
<ul style="list-style-type: none"> • With send clock of 250 µs 	250 µs to 4 ms
<ul style="list-style-type: none"> • With send clock of 500 µs 	500 µs to 8 ms
<ul style="list-style-type: none"> • With send clock of 1 ms 	1 ms to 16 ms
<ul style="list-style-type: none"> • With send clock of 2 ms 	2 ms to 32 ms
<ul style="list-style-type: none"> • With send clock of 4 ms 	4 ms to 64 ms
<ul style="list-style-type: none"> • With IRT with the "high performance" option and parameter assignment for so-called "uneven" send clocks 	Update time = set "odd" send clock (any multiple of 125 µs: 375 µs, 625 µs to 3.875 µs)
PROFINET IO device	
Services	
<ul style="list-style-type: none"> • PG/OP communication 	Yes
<ul style="list-style-type: none"> • S7 routing 	Yes
<ul style="list-style-type: none"> • Isochronous mode 	No
<ul style="list-style-type: none"> • Open IE communication 	Yes
<ul style="list-style-type: none"> • IRT 	Yes
<ul style="list-style-type: none"> • MRP 	Yes
<ul style="list-style-type: none"> • PROFIenergy 	Yes
<ul style="list-style-type: none"> • Shared device 	Yes
<ul style="list-style-type: none"> • Number of IO controllers with shared device, max. 	4
SIMATIC communication	
S7 communication, as server	Yes
S7 communication, as client	Yes
User data per job, max.	See online help (S7 communication, user data size)

	6ES7512-1SK00-0AB0
Open IE communication	
TCP/IP	Yes
<ul style="list-style-type: none"> Data length, max. 	64 KB
<ul style="list-style-type: none"> Several passive connections per port, supported 	Yes
ISO-on-TCP (RFC1006)	
<ul style="list-style-type: none"> Data length, max. 	64 KB
UDP	
<ul style="list-style-type: none"> Data length, max. 	1472 bytes
DHCP	
SNMP	
DCP	
LLDP	
Web server	
HTTP	
Yes; standard and user-defined pages	
HTTPS	
Yes; standard and user-defined pages	
PROFIBUS DP master	
Number of connections, max.	
48	
Services	
<ul style="list-style-type: none"> PG/OP communication 	Yes
<ul style="list-style-type: none"> S7 routing 	Yes
<ul style="list-style-type: none"> Data record routing 	Yes
<ul style="list-style-type: none"> Isochronous mode 	No
<ul style="list-style-type: none"> Constant bus cycle time 	No
<ul style="list-style-type: none"> Number of DP slaves 	125
<ul style="list-style-type: none"> Activation/deactivation of DP slaves 	Yes
Additional protocols	
MODBUS	
Yes; MODBUS TCP	
Media redundancy	
Switchover time on line interruption, typ.	
200 ms	
Number of devices in the ring, max.	
50	
Isochronous mode	
Isochronous mode (application synchronized up to terminal)	
Yes; only with PROFINET; with a minimum OB 6x cycle of 625 μs	
S7 signaling functions	
Number of stations that can be registered for signaling functions, max.	
32	
Block-related alarms	
Yes	
Number of configurable interrupts, max.	
5000	
Number of simultaneously active interrupts in interrupt pool	

6ES7512-1SK00-0AB0	
<ul style="list-style-type: none"> • Number of reserved user interrupts 	300
<ul style="list-style-type: none"> • Number of reserved interrupts for system diagnostics 	100
<ul style="list-style-type: none"> • Number of reserved interrupts for motion technology objects 	80
Test/commissioning functions	
Shared commissioning (Team Engineering)	Yes; parallel online access possible for up to 3 engineering systems
Status block	Yes; up to 8 simultaneously (in total from all ES clients)
Single step	No
Status/force	
Status/force tag	Yes
Tags	Inputs, outputs, bit memories, DBs, timers, counters
Of which are status tags, max.	200; per job
Of which are force tags, max.	200; per job
Force	
Force	Yes
Force, tags	Inputs, outputs
Number of tags, max.	200
Diagnostics buffer	
Available	Yes
Number of entries, max.	1000
<ul style="list-style-type: none"> • Of which are protected against power failure 	500
Traces	
Number of configurable traces	4; up to 512 KB data per trace possible
Interrupts/diagnostics/status information	
Diagnostic display LED	
RUN/STOP LED	Yes
ERROR LED	Yes
MAINT LED	Yes
Monitoring of the supply voltage (PWR LED)	Yes
Connection display LINK TX/RX	Yes
Supported technology objects	
Motion	Yes
<ul style="list-style-type: none"> • Speed-controlled axis <ul style="list-style-type: none"> – Number of speed-controlled axes, max. 	6; max. number of speed-controlled axes (requirement: no other motion technology objects have been created)
<ul style="list-style-type: none"> • Positioning axis 	

6ES7512-1SK00-0AB0	
<ul style="list-style-type: none"> - Number of positioning axes, max. 	6; max. number of positioning axes (requirement: no other motion technology objects have been created)
<ul style="list-style-type: none"> • Synchronous axes (relative gearing) <ul style="list-style-type: none"> - Number of axes, max. 	3; max. number of synchronous axes (requirement: no other motion technology objects have been created)
<ul style="list-style-type: none"> • External encoders <ul style="list-style-type: none"> - Number of external encoders, max. 	6; max. number of external encoders (requirement: no other motion technology objects have been created)
Controller	
<ul style="list-style-type: none"> • PID_Compact 	Yes; universal PID controller with integrated optimization
<ul style="list-style-type: none"> • PID_3Step 	Yes; PID controller with integrated optimization for valves
<ul style="list-style-type: none"> • PID temp 	Yes; PID controller with integrated optimization for temperature
Counting and measuring	
<ul style="list-style-type: none"> • High-speed counter 	Yes
Standards, approvals, certificates	
Suitable for safety functions	Yes; e.g., emergency stop, acknowledgment button
Maximum achievable safety class in safety mode	
Performance level according to EN ISO 13849-1:2008	PLe
SIL according to IEC 61508:2010	SIL 3
Low demand mode: PFDavg	< 2.00E-05
High demand/continuous mode: PFH	< 1.00E-09
Ambient conditions	
Ambient temperature in operation	
Horizontal installation, min.	0 °C
Horizontal installation, max.	60 °C
Vertical installation, min.	0 °C
Vertical installation, max.	50 °C
Storage/transport temperature	
Min.	-40 °C
Max.	70 °C

	6ES7512-1SK00-0AB0
Configuration	
Programming	
Programming language	
• LAD	Yes; with fail-safe
• FBD	Yes; with fail-safe
• STL	Yes
• SCL	Yes
• GRAPH	Yes
Know-how protection	
User program protection	Yes
Copy protection	Yes
Block protection	Yes
Access protection	
Protection level: Write protection	Yes; a specific write protection in each case for both standard and fail-safe
Protection level: Read/write protection	Yes
Protection level: Complete protection	Yes
Cycle time monitoring	
Low limit	Configurable minimum cycle time
High limit	Configurable maximum cycle time
Dimensions	
Width	100 mm
Height	117 mm
Depth	75 mm
Weights	
Weight, approx.	310 g

General technical specifications

You can find information on the general technical specifications, such as standards and approvals, electromagnetic compatibility, protection class, etc., in the system manual ET 200SP distributed I/O system.

Dimension drawing

This section contains a dimension drawing of the module mounted on a mounting rail. Always observe the specified dimensions for installation in cabinets, control rooms, etc.

Dimension drawing of the CPU 1512SP-1 PN

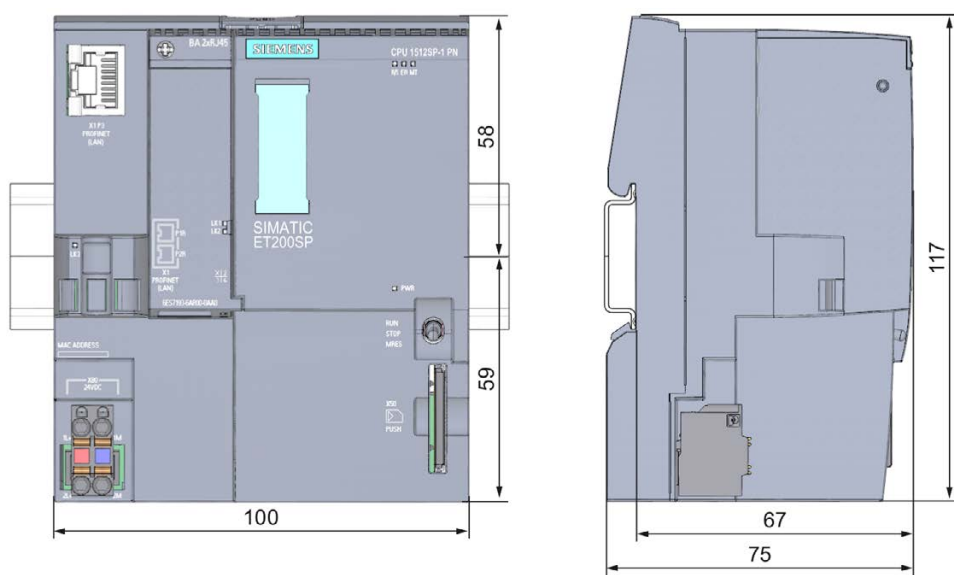

Figure A-1 Dimension drawing CPU 1512SP-1 PN