

# SIEMENS

SIRIUS

Vakuumschütz  
Vaccum contactor  
Contacteur sous vide  
Contactor en vacío  
Contattore sotto vuoto  
Contactor de vacío  
Vakum kontaktörü  
Вакуумный контактор

3RT126.-A/N  
3RT127.-A/N



EN 1088(5.7)



Betriebsanleitung	Operating Instructions	Instructions de service	Instructivo
Istruzioni operative	Instruções de Serviço	İşletme kılavuzu	Руководство по эксплуатации

	Deutsch	English	Français	Español
	Vor der Installation, dem Betrieb oder der Wartung des Geräts muss diese Anleitung gelesen und verstanden werden.	Read and understand these instructions before installing, operating, or maintaining the equipment.	Ne pas installer, utiliser ou intervenir sur cet équipement avant d'avoir lu et assimilé ces instructions.	Leer y comprender este instructivo antes de la instalación, operación o mantenimiento del equipo.
	<b>⚠ GEFAHR</b>	<b>⚠ DANGER</b>	<b>⚠ DANGER</b>	<b>⚠ PELIGRO</b>
	<b>Gefährliche Spannung. Lebensgefahr oder schwere Verletzungsgefahr.</b> Vor Beginn der Arbeiten Anlage und Gerät spannungsfrei schalten.	<b>Hazardous voltage. Will cause death or serious injury.</b> Disconnect power before working on equipment.	<b>Tension dangereuse. Danger de mort ou risque de blessures graves.</b> Mettez hors tension avant d'intervenir sur l'appareil.	<b>Tensión peligrosa. Puede causar la muerte o lesiones graves.</b> Desconectar la alimentación eléctrica antes de trabajar en el equipo.
	<b>VORSICHT</b>	<b>CAUTION</b>	<b>PRUDENCE</b>	<b>PRECAUCIÓN</b>
	Eine sichere Gerätefunktion ist nur mit zertifizierten Komponenten gewährleistet.	Reliable functioning of the equipment is only ensured with certified components.	Le fonctionnement sûr de l'appareil n'est garanti qu'avec des composants certifiés.	El funcionamiento seguro del aparato sólo está garantizado con componentes certificados.

	Italiano	Português	Türkçe	Русский
	Leggere con attenzione queste istruzioni prima di installare, utilizzare o eseguire manutenzione su questa apparecchiatura.	Ler e compreender estas instruções antes da instalação, operação ou manutenção do equipamento.	Cihazın kurulumundan, çalıştırılmasından veya bakıma tabi tutulmasından önce, bu kılavuz okunmuş ve anlaşılmış olmalıdır.	Перед установкой, вводом в эксплуатацию или обслуживанием устройства необходимо прочесть и понять данное руководство.
	<b>⚠ PERICOLO</b>	<b>⚠ PERIGO</b>	<b>⚠ TEHLİKE</b>	<b>⚠ ОПАСНО</b>
	<b>Tensione pericolosa. Può provocare morte o lesioni gravi.</b> Scollegare l'alimentazione prima di eseguire interventi sull'apparecchiatura.	<b>Tensão perigosa. Perigo de morte ou ferimentos graves.</b> Desligue a corrente antes de trabalhar no equipamento.	<b>Tehlikeli gerilim. Ölüm tehlikesi veya ağır yaralanma tehlikesi.</b> Çalışmalara başlamadan önce, sistemin ve cihazın gerilim beslemesini kapatınız.	<b>Опасное напряжение. Опасность для жизни или возможность тяжелых травм.</b> Перед началом работ отключить подачу питания к установке и к устройству.
	<b>CAUTELA</b>	<b>CUIDADO</b>	<b>ÖNEMLİ DİKKAT</b>	<b>ОСТОРОЖНО</b>
	Il funzionamento sicuro dell'apparecchiatura è garantito soltanto con componenti certificati.	O funcionamento seguro do aparelho apenas pode ser garantido se forem utilizados os componentes certificados.	Cihazın güvenli çalışması ancak sertifikalı bileşenler kullanılması halinde garanti edilebilir.	Безопасность работы устройства гарантировано только при использовании сертифицированных компонентов.

**Technical Assistance:** Telephone: +49 (911) 895-5900 (8° - 17° CET)  
Fax: +49 (911) 895-5907  
E-mail: [technical-assistance@siemens.com](mailto:technical-assistance@siemens.com)  
Internet: [www.siemens.com/industrial-controls/technical-assistance](http://www.siemens.com/industrial-controls/technical-assistance)

**SIEMENS AG**  
**Technical Assistance**  
**Würzburger Str. 121**  
**D-90766 Fürth**

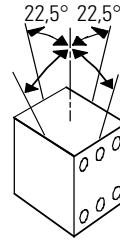
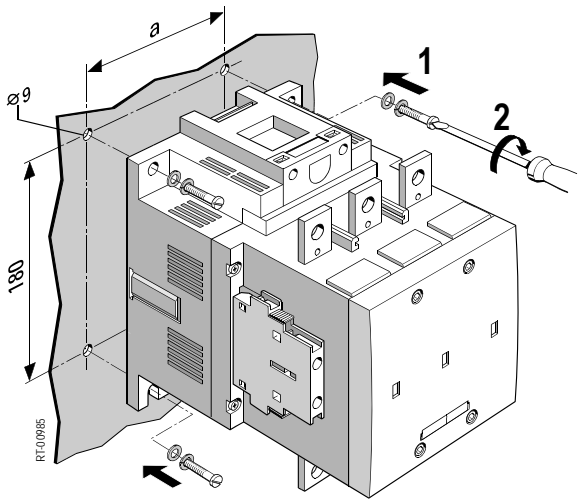

	3RT126.	3RT127.
a	120	130

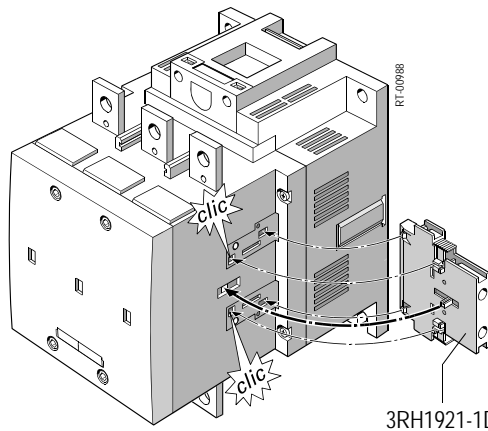
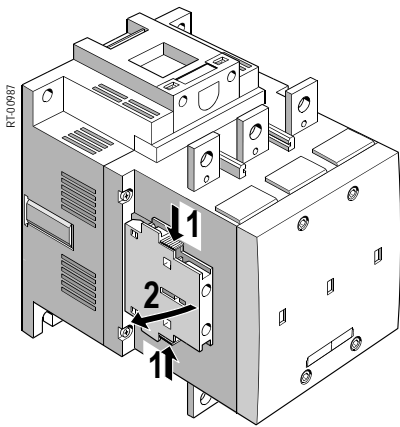

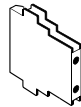
NC/NO: max. Stck. / pc.

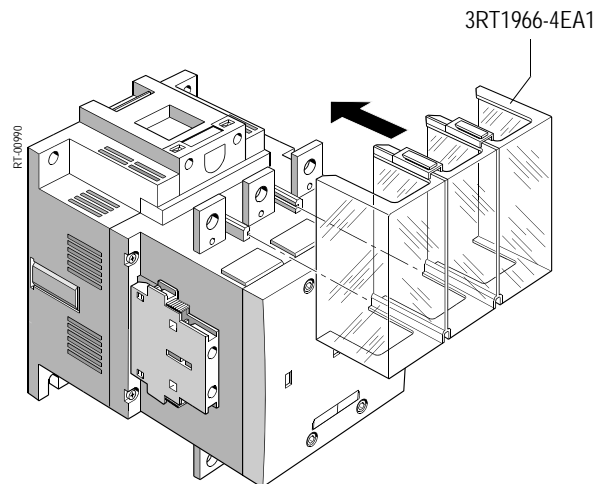
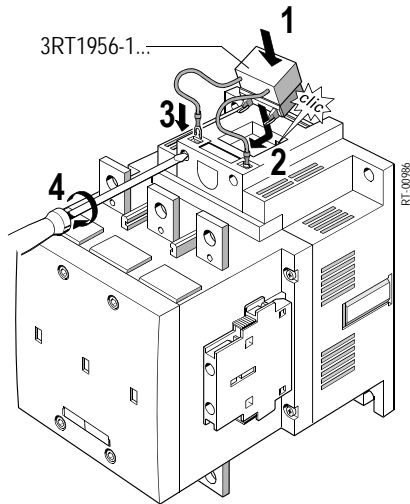
4 NC + 4 NO
2 NC + 6 NO
0 NC + 8 NO

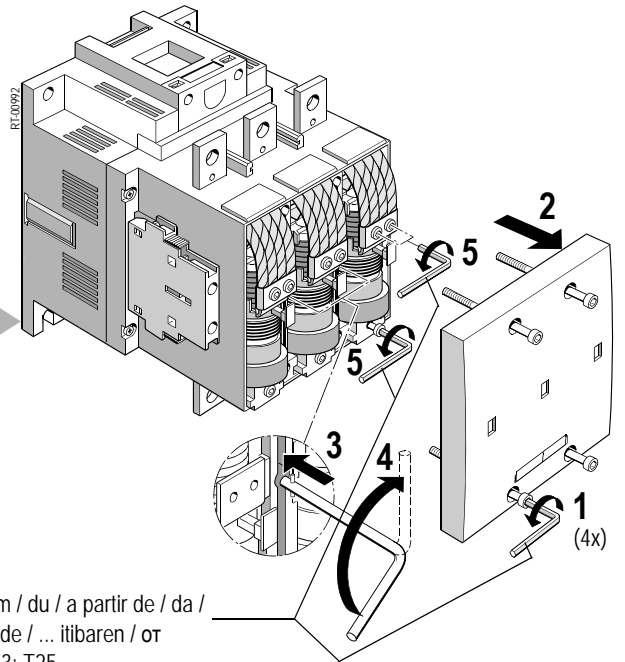
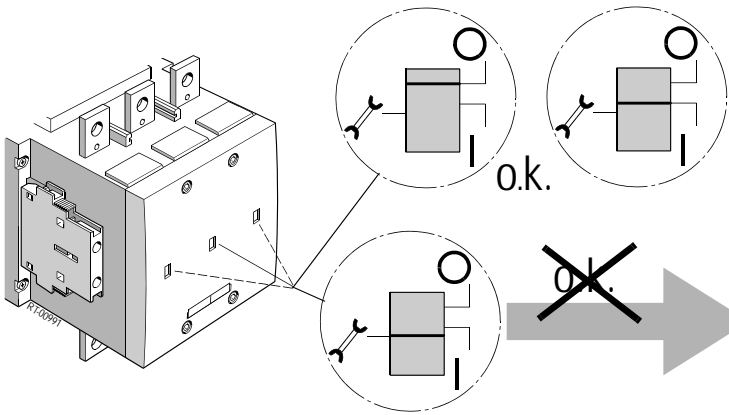
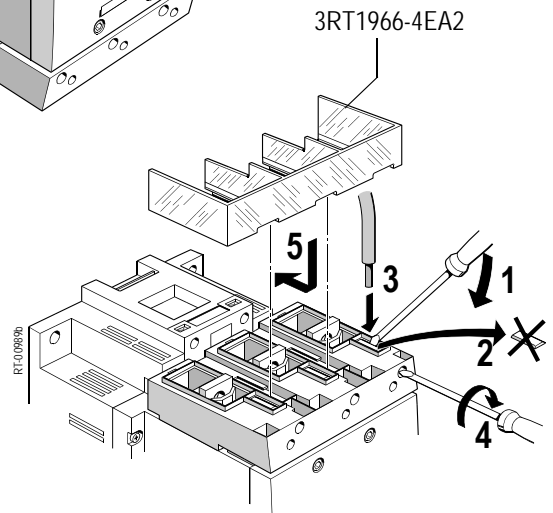
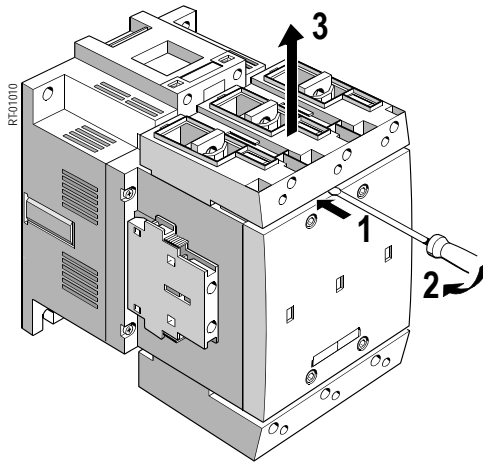
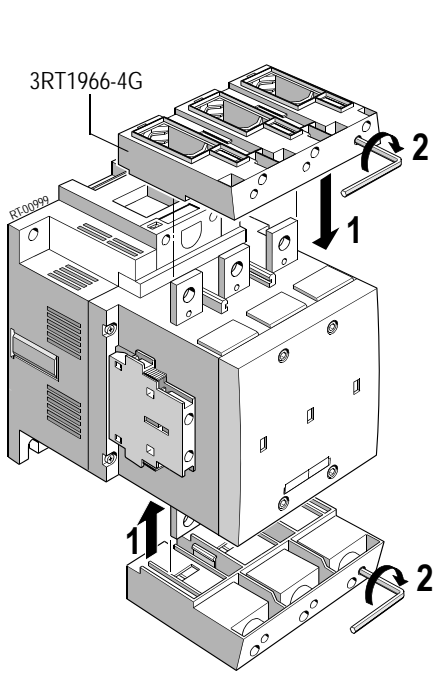



SW4;  
 ab / from / du / a partir de / da /  
 a partir de / ... itibaren / or  
 02-12-13: T25





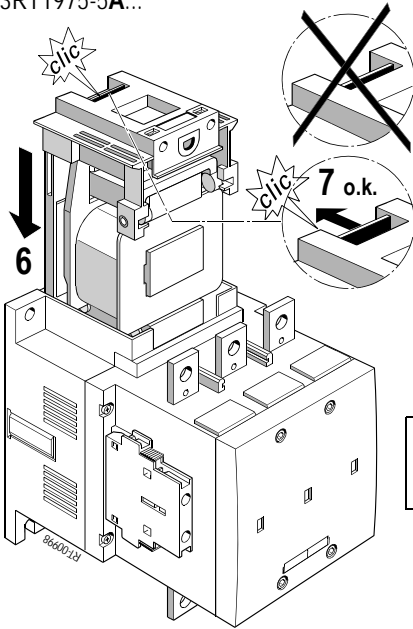



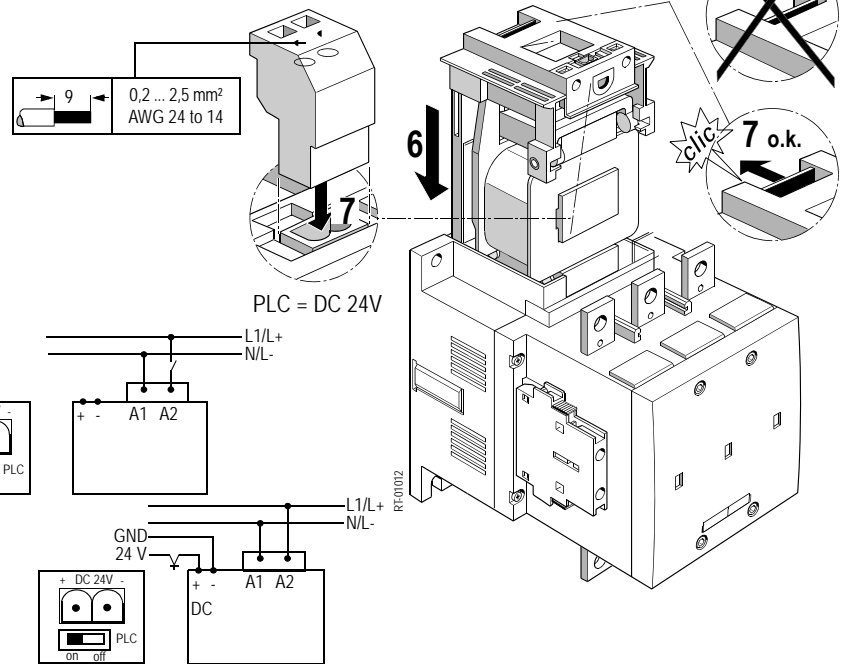

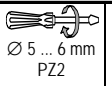



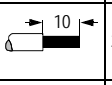

3RT1966-5A...  
3RT1975-5A...

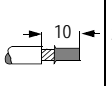

3RT1966-5N...  
3RT1975-5N...



A1/A2; NO/NC 3RH1921-1		L1, L2, L3; T1, T2, T3 3RT1966-4G			3RT126 3RT127	
	0,8 ... 1,2 Nm 7 to 10.3 lb-in					
	2 x 0,5 ... 1,5 mm <sup>2</sup> 2 x 0,75 ... 2,5 mm <sup>2</sup> 2 x AWG 18 to 14		1 x 95 ... 300 mm <sup>2</sup>	1 x 120 ... 240 mm <sup>2</sup>	min. 70 + 70 mm <sup>2</sup> max. 240 + 240 mm <sup>2</sup>	
	2 x 0,5 ... 2,5 mm <sup>2</sup> 2 x AWG 18 to 14		1 x 70 ... 240 mm <sup>2</sup>	1 x 120 ... 185 mm <sup>2</sup>	min. 50 + 50 mm <sup>2</sup> max. 185 + 185 mm <sup>2</sup>	
						
				min. 6 x 9 x 0,8 max.: 20 x 24 x 0,5 11 x 21 x 1		

3RH1921-2....

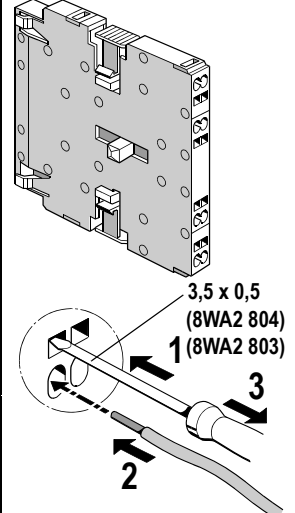

3RT126

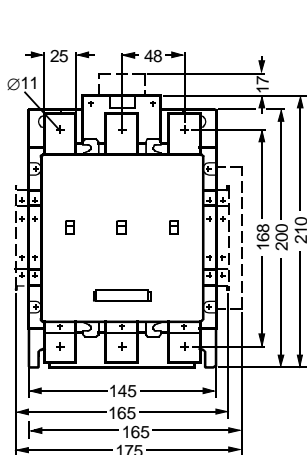

3RT127

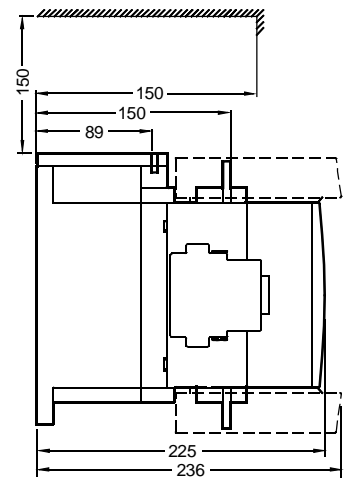
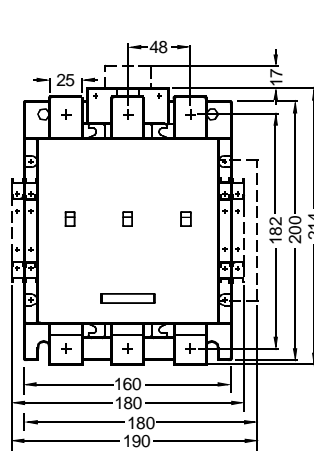

Technische Änderungen vorbehalten. Zum späteren Gebrauch aufbewahren.  
Subject to change without prior notice. Store for use at a later date.

3ZX1012-0RT64-1VA1  
© Siemens AG 2001