

SIMOCODE® pro

Stromerfassungsmodul

Current Measuring Module

Module d'acquisition de courant

Módulo medidor de corriente

Modulo di rilevamento corrente



Módulo de captura da corrente

3UF710.-1.A00-0







Betriebsanleitung Instructivo	Operating Instructions Istruzioni operative	Instructions de service Instruções de Serviço	Bestell-Nr./Order No.: 3ZX1012-0UF71-1AA1
--	--	--	--

Vor der Installation, dem Betrieb oder der Wartung des Geräts muss diese Anleitung gelesen und verstanden werden.
 Read and understand these instructions before installing, operating, or maintaining the equipment.
 Ne pas installer, utiliser ou entretenir cet équipement avant d'avoir lu et assimilé ce instructions.
 Leer y comprender este instructivo antes de la instalación, operación o mantenimiento del equipo.
 Leggere con attenzione questi istruzioni prima di installare, utilizzare o eseguire manutenzione su questa apparecchiatura.
 Ler e compreender estas instruções antes da instalação, operação ou manutenção do equipamento.

 	⚠ GEFAHR Gefährliche Spannung. Lebensgefahr oder Gefahr schwerer Verletzung. Vor Beginn der Arbeiten Anlage und Gerät spannungsfrei schalten.	⚠ DANGER Hazardous voltage. Will cause death or serious injury. Disconnect power before working on equipment.	⚠ DANGER Tension dangereuse. Danger de mort ou risque de blessures graves. Mettre hors tension avant d'intervenir sur l'appareil.
	⚠ PELIGRO Tensión peligrosa. Puede causar la muerte o lesiones graves. Desconectar la alimentación eléctrica antes de trabajar en el equipo.	⚠ PERICOLO Tensione pericolosa. Può provocare morte o lesioni gravi. Scollegare l'alimentazione prima di eseguire eventuali interventi all'equipaggiamento.	⚠ PERIGO Tensão perigosa. Perigo de morte ou ferimentos graves. Desligue a corrente antes de trabalhar no equipamento.

Eine sichere Gerätefunktion ist nur mit zertifizierten Komponenten gewährleistet!
 Reliable functioning of the equipment is only ensured with certified components.
 Le fonctionnement sûr de l'appareil n'est garanti qu'avec des composants certifiés.
 El funcionamiento seguro del aparato sólo está garantizado con componentes certificados.
 Il funzionamento sicuro dell'apparecchiatura viene garantito soltanto con componenti certificati.
 O funcionamento seguro do aparelho apenas pode ser garantido se forem utilizados os componentes certificados.

Weitere Informationen: For further information: Pour de plus amples informations : Más información: Per ulteriori informazioni: Mais informações:	  SIMOCODE pro System Deutsch: 3UF7970-0AA01-0  SIMOCODE pro Système Français: 3UF7970-0AA02-0	 SIMOCODE pro System English: 3UF7970-0AA00-0
--	--	---

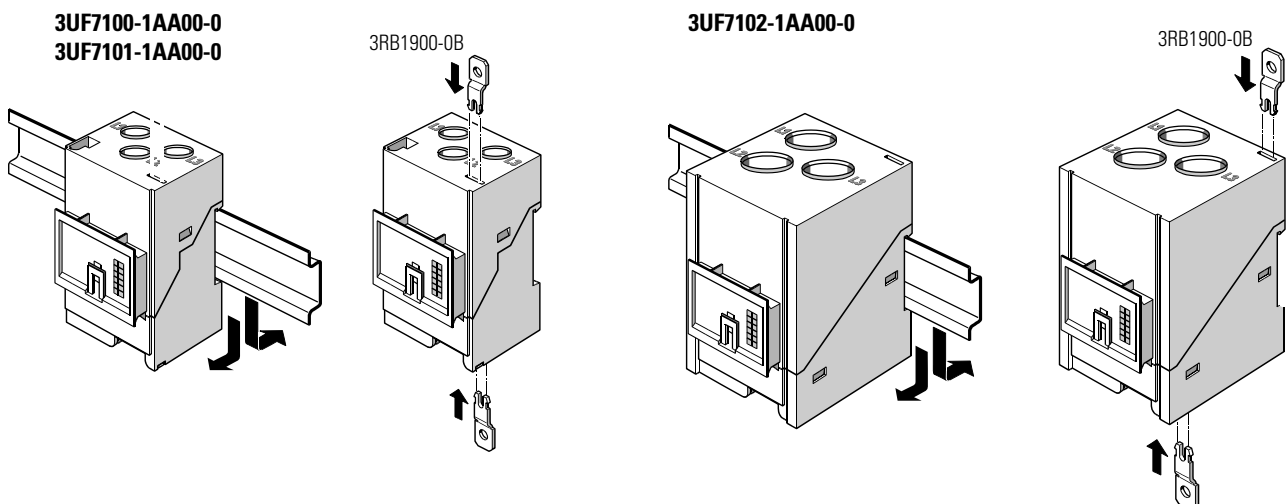

3UF7103-1AA00-0

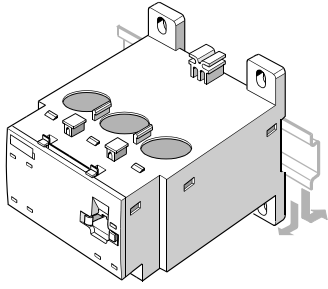

3UF7103-1BA00-0

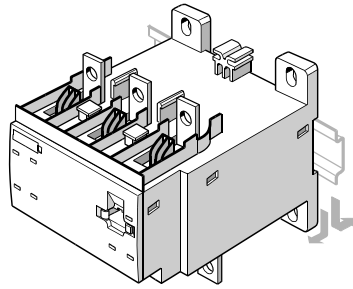

3UF7104-1BA00-0

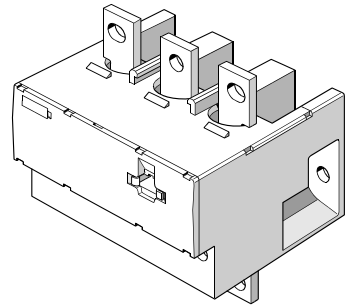

3UF7100-1AA00-0
3UF7101-1AA00-0

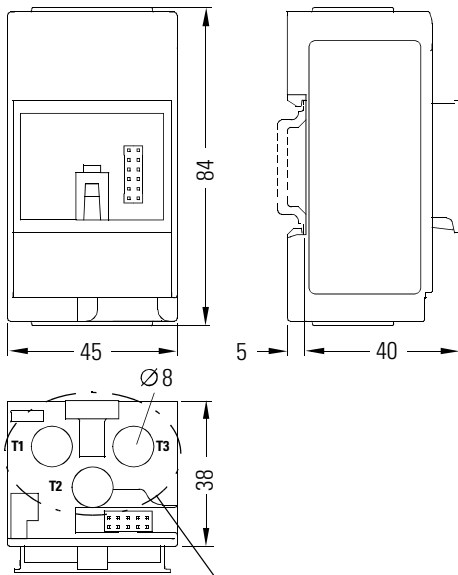

3UF7102-1AA00-0

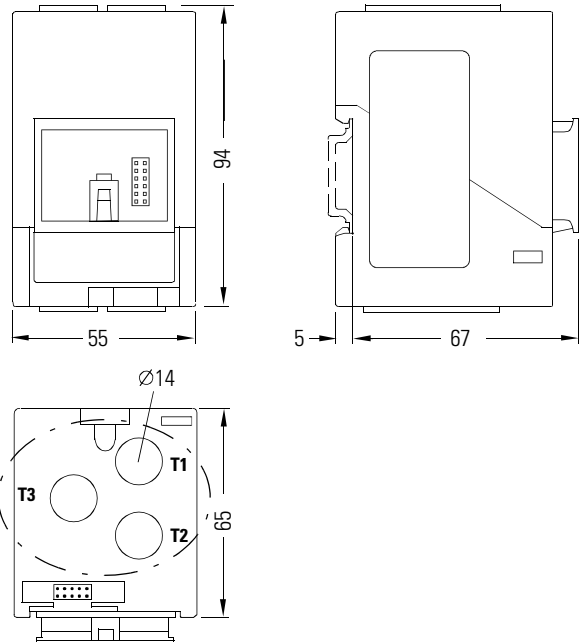

Durchstecköffnungen für Motorzuleitungen
Let-through openings for motor lines
Traversées pour entrées de moteur
Abertura para cables de motor
Apertura a foro passante per alimentazione del motore
Aberturas de passagem para condutores de alimentação de motores

3UF7103-1AA00-0

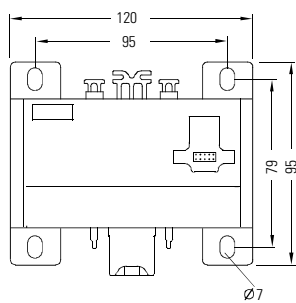

3UF7103-1BA00-0

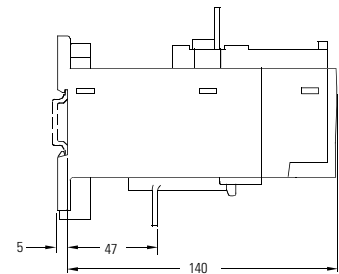
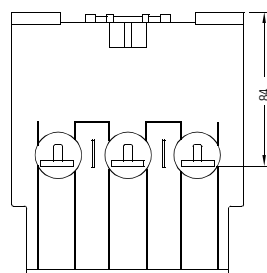
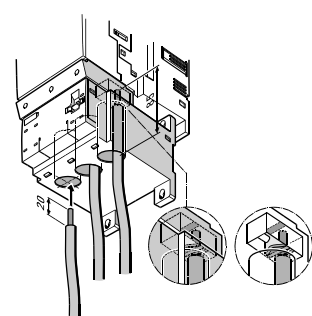
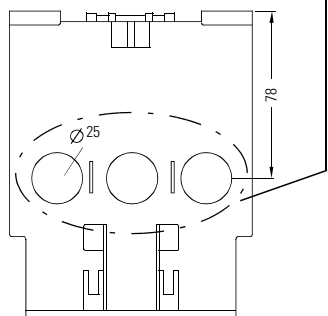
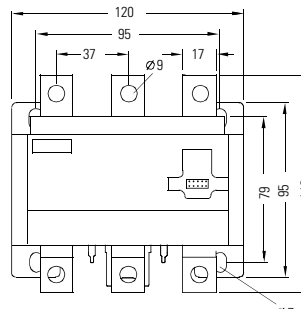

3UF7104-1BA00-0

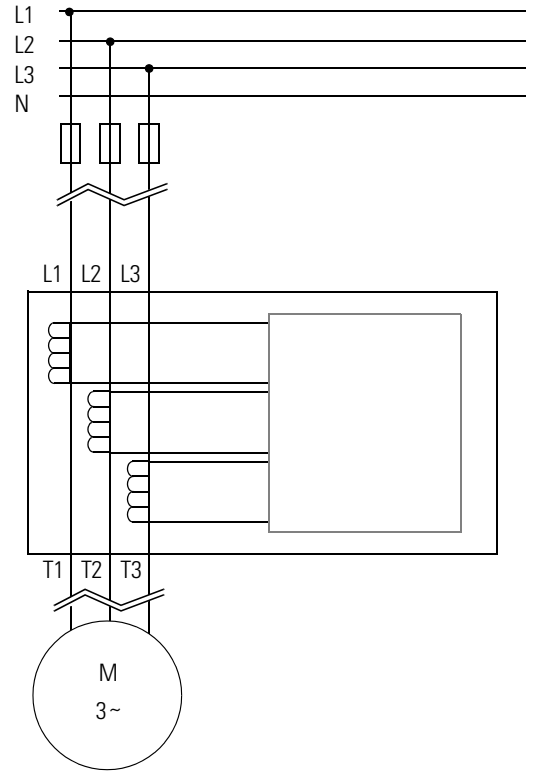
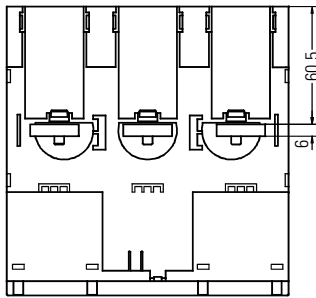
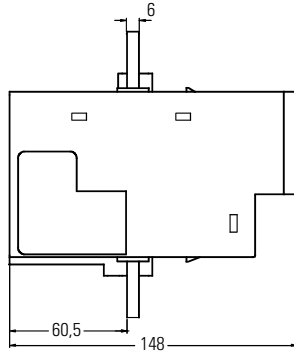
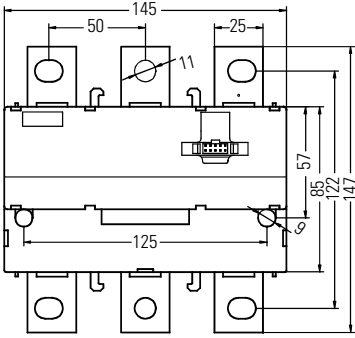

Order No.	I [A]	Ø [mm]	L1/L2/L3
3UF7100-1AA00-0	0.3 ... 3 A	7.5	
3UF7101-1AA00-0	2.4 ... 25 A	7.5	
3UF7102-1AA00-0	10 ... 100 A	14	
3UF7103-1AA00-0	20 ... 200 A	25	
Order No.	I [A]	A [mm ²]/AWG	L1/L2/L3
3UF7103-1BA00-0	20 ... 200 A	16 ... 95 mm ² AWG 6 to 3/0	
3UF7104-1BA00-0	63 ... 630 A	50 ... 240 mm ² AWG 1/0 to 500 kcmil	

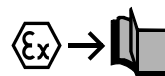
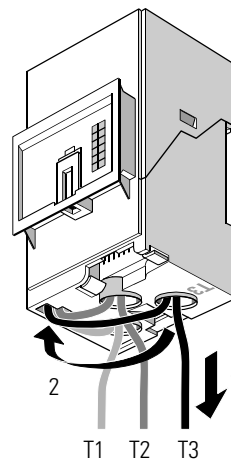
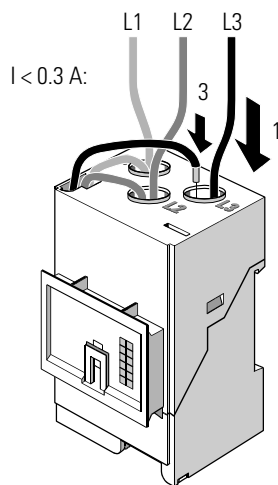
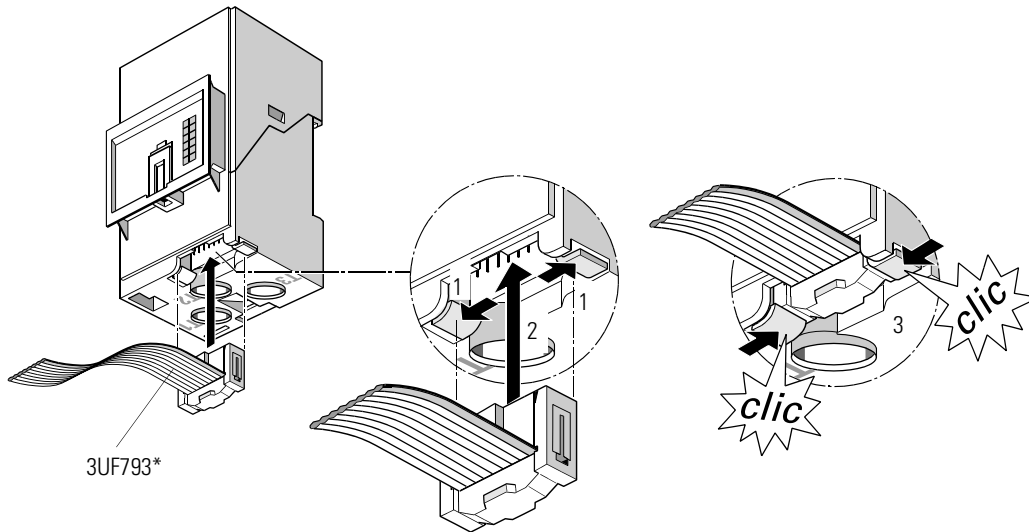

Deutsch: 3UF7970-0AA01-0
 English: 3UF7970-0AA00-0
 Français: 3UF7970-0AA02-0

Technical Assistance: Telephone: +49 (0) 911-895-5900 (8⁰⁰ - 17⁰⁰ CET)
 E-mail: technical-assistance@siemens.com
 Internet: www.siemens.de/lowvoltage/technical-assistance

Fax: +49 (0) 911-895-5907

Technical Support: Telephone: +49 (0) 180 50 50 222

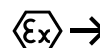

www.siemens.com/lowvoltage/manuals

Technische Änderungen vorbehalten. Zum späteren Gebrauch aufbewahren!
 Subject to change without prior notice. Store for use at a later date.
 © Siemens AG 2006

Bestell-Nr./Order No.: 3ZX1012-0UF71-1AA1
 Printed in the Federal Republic of Germany