

SIMOCODE® pro
Bedienbaustein mit Display
Operator panel with display
Module frontal avec afficheur
Módulo de mando con display
Modulo di comando con display
Módulo de Comando com Display
Ekranlı kumanda ünitesi
Блок управления с дисплеем

3UF7210-1.A00-0



Betriebsanleitung	Operating Instructions	Instructions de service	Instructivo
Istruzioni operative	Instruções de Serviço	İşletme kılavuzu	Руководство по эксплуатации

Vor der Installation, dem Betrieb oder der Wartung des Geräts muss diese Anleitung gelesen und verstanden werden.
 Read and understand these instructions before installing, operating, or maintaining the equipment.
 Ne pas installer, utiliser ou entretenir cet équipement avant d'avoir lu et assimilé ces instructions.
 Leer y comprender este instructivo antes de la instalación, operación o mantenimiento del equipo.
 Leggere con attenzione questi istruzioni prima di installare, utilizzare o eseguire manutenzione su questa apparecchiatura.
 Ler e compreender estas instruções antes da instalação, operação ou manutenção do equipamento.
 Cihazın kurulumundan, çalıştırılmasından veya bakıma tabi tutulmasından önce, bu kılavuz okunmuş ve anlaşılmış olmalıdır.
 Перед установкой, вводом в эксплуатацию или обслуживанием устройства необходимо прочесть и понять данное руководство.

Eine sichere Gerätefunktion ist nur mit zertifizierten Komponenten gewährleistet.
 Reliable functioning of the equipment is only ensured with certified components.
 Le fonctionnement sûr de l'appareil n'est garanti qu'avec des composants certifiés.
 El funcionamiento seguro del aparato sólo está garantizado con componentes certificados.
 Il funzionamento sicuro dell'apparechiatura viene garantito soltanto con componenti certificati.
 O funcionamento seguro do aparelho apenas pode ser garantido se forem utilizados os componentes certificados.
 Cihazın güvenli çalışması ancak sertifikalı bileşenler kullanılması halinde garanti edilebilir.
 Надежное функционирование устройства гарантировано только при задействовании сертифицированных компонентов.

	DE	<ul style="list-style-type: none"> • Systemhandbuch SIMOCODE pro PROFIBUS • Systemhandbuch SIMOCODE pro PROFINET 	www.siemens.com/sirius/manuals
	EN	<ul style="list-style-type: none"> • System Manual SIMOCODE pro PROFIBUS • System Manual SIMOCODE pro PROFINET 	
	FR	<ul style="list-style-type: none"> • Manuel système SIMOCODE pro PROFIBUS • Manuel système SIMOCODE pro PROFINET 	
	ES	<ul style="list-style-type: none"> • Manual de sistema SIMOCODE pro PROFIBUS • Manual de sistema SIMOCODE pro PROFINET 	



Das Gerät darf nur im spannungsfreien Zustand gesteckt beziehungsweise gezogen werden.
 It is only permissible to insert or withdraw the equipment in a no-voltage state.
 Le équipement ne doit être enfiché et débranché qu'à l'état hors tension.
 El aparato sólo deberá enchufarse y desenchufarse con la tensión desconectada.
 Il apparecchiatura può essere estratto oppure inserito solo dopo la messa fuori tensioni.
 Só pode ser conectado ou puxado livre de tensão.
 Sadece gerilim olmadan sokulup veya çıkartılabilir.
 Выдергивать или вставлять только в состоянии без напряжения.

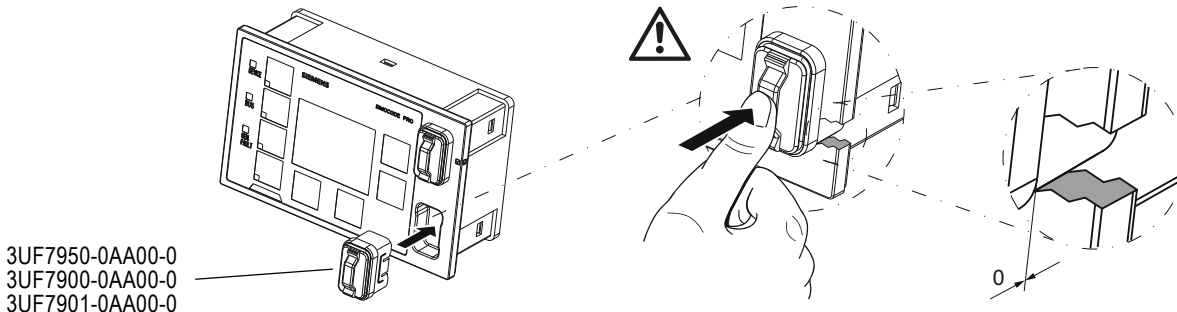

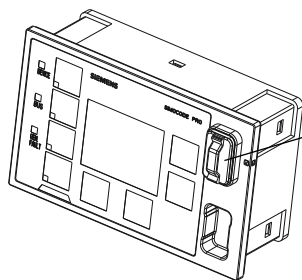

3UF7950-0AA00-0
3UF7900-0AA00-0
3UF7901-0AA00-0

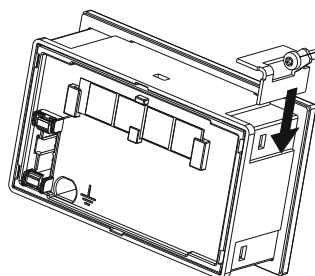
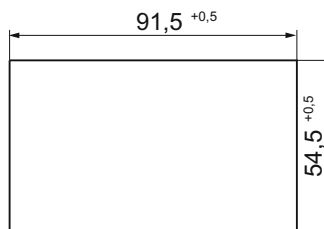

4x (0,15 + 0,05 Nm)

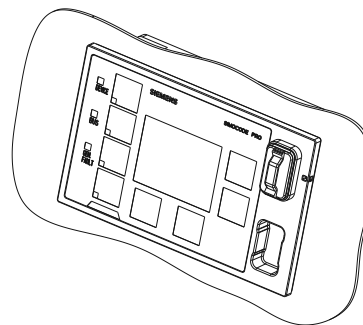

Depot für Bezeichnungstreifen
Holder for legend strips
Rangement pour bandes de repérage
Soporte para tiras de identificación
Deposito per etichette descrittive
Depósito para tiras de designação
İsimlendirme şeritleri deposu
Место для этикеток

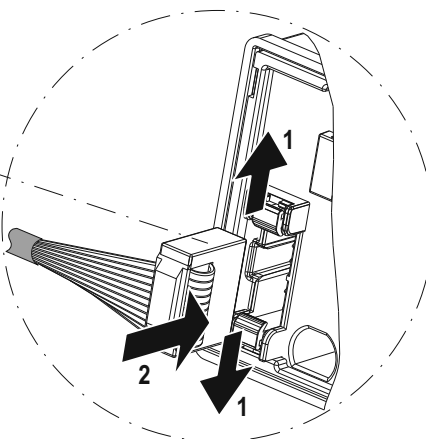
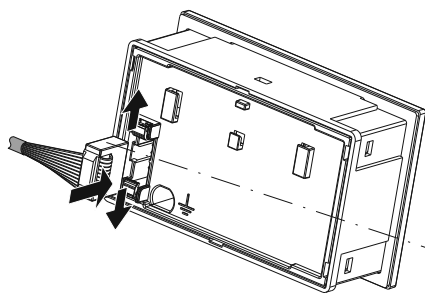
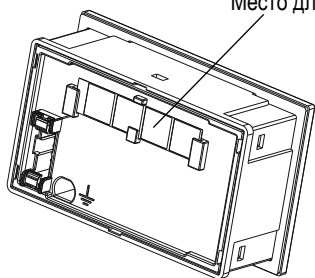
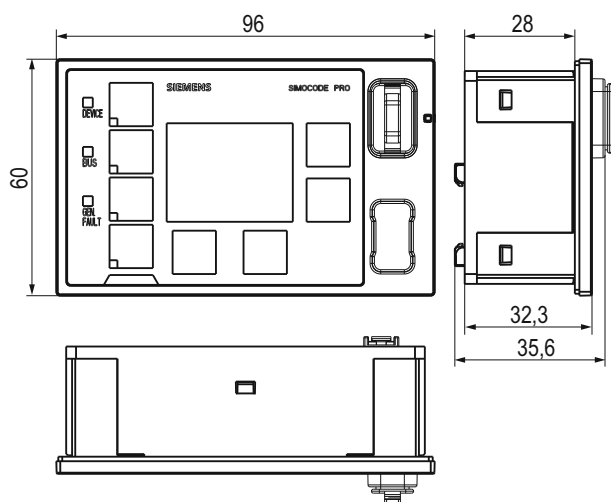

3UF793*

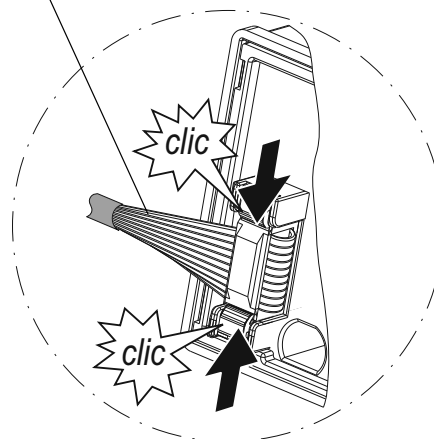

Technical Assistance: Telephone: +49 (911) 895-5900 (8°° - 17°° CET)
Fax: +49 (911) 895-5907
E-mail: technical-assistance@siemens.com
Internet: www.siemens.com/sirius/technical-assistance

SIEMENS AG
Technical Assistance
Breslauer Str. 5
D-90766 Fürth