

SIRIUS

Überwachungsrelais zur Phasenfolge- und Unterspannungsüberwachung

Monitoring relay for phase sequence and undervoltage monitoring

Relais de contrôle de l'ordre des phases et de minimum de tension

Relé de vigilancia de secuencias y relé de vigilancia de mínima tensión

Relè di controllo sequenza fasi e di sottotensione

Relé de monitoramento de sequência das fases e vigilância de subtensão



Faz sırası ve düşük gerilim kontrolü için kontrol rölesi

Реле контроля чередования фаз и понижения напряжения

用于监控相序和欠压的监控继电器

 EN/IEC 60 947

Betriebsanleitung Operating Instructions Instructions de service Instructivo Istruzioni operative
 Instruções de Serviço İşletme kılavuzu Руководство по эксплуатации 使用说明





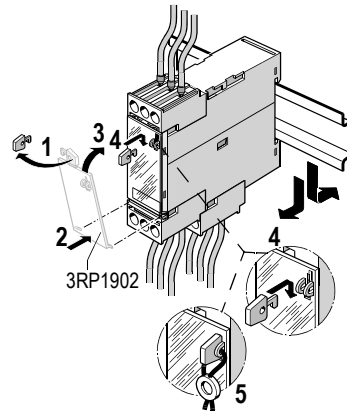
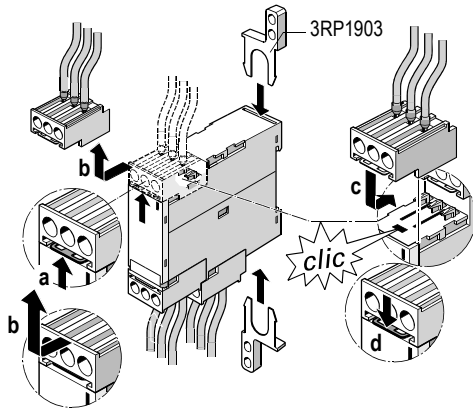

	Deutsch	English	Français
	Vor der Installation, dem Betrieb oder der Wartung des Geräts muss diese Anleitung gelesen und verstanden werden.	Read and understand these instructions before installing, operating, or maintaining the equipment.	Ne pas installer, utiliser ou intervenir sur cet équipement avant d'avoir lu et assimilé les présentes instructions et notamment les conseils de sécurité et mises en garde qui y figurent.
	⚠ GEFÄHR	⚠ DANGER	⚠ DANGER
	Gefährliche Spannung. Lebensgefahr oder schwere Verletzungsgefahr. Vor Beginn der Arbeiten Anlage und Gerät spannungsfrei schalten.	Hazardous voltage. Will cause death or serious injury. Turn off and lock out all power supplying this device before working on this device.	Tension électrique. Danger de mort ou risque de blessures graves. Mettez hors tension avant d'intervenir sur l'appareil.
	VORSICHT	CAUTION	PRUDENCE
	Eine sichere Gerätefunktion ist nur mit zertifizierten Komponenten gewährleistet.	Reliable functioning of the equipment is only ensured with certified components.	La sécurité de fonctionnement de l'appareil n'est garantie qu'avec des composants certifiés.
	Español	Italiano	Português
	Leer y comprender este instructivo antes de la instalación, operación o mantenimiento del equipo.	Leggere con attenzione queste istruzioni prima di installare, utilizzare o eseguire manutenzione su questa apparecchiatura.	Ler e compreender estas instruções antes da instalação, operação ou manutenção do equipamento.
	⚠ PELIGRO	⚠ PERICOLO	⚠ PERIGO
	Tensión peligrosa. Puede causar la muerte o lesiones graves. Desconectar la alimentación eléctrica antes de trabajar en el equipo.	Tensione pericolosa. Può provocare morte o lesioni gravi. Scollegare l'alimentazione prima di eseguire interventi sull'apparecchiatura.	Tensão perigosa. Perigo de morte ou ferimentos graves. Desligue a alimentação elétrica e proteja contra o religamento, antes de iniciar o trabalho no equipamento.
	PRECAUCIÓN	CAUTELA	CUIDADO
	El funcionamiento seguro del aparato sólo está garantizado con componentes certificados.	Il funzionamento sicuro dell'apparecchiatura è garantito soltanto con componenti certificati.	O funcionamento seguro do aparelho apenas pode ser garantido se forem utilizados os componentes certificados.
	Türkçe	Русский	中文
	Cihazın kurulumundan, çalıştırılmasından veya bakıma tabi tutulmasından önce, bu kılavuzun okunmuş ve anlaşılmış olması gerekmektedir.	Перед установкой, вводом в эксплуатацию или обслуживанием устройства необходимо прочесть и понять данное руководство.	安装、使用和维修本设备前必须先阅读并理解本说明。
	⚠ TEHLİKE	⚠ ОПАСНО	⚠ 危险
	Tehlikeli gerilim. Ölüm tehlikesi veya ağır yaralanma tehlikesi. Çalışmalara başlamadan önce, sistemin ve cihazın gerilim beslemesini kapatınız.	Опасное напряжение. Опасность для жизни или возможность тяжелых травм. Перед началом работ отключить подачу питания к установке и к устройству.	危险电压。可能导致生命危险或重伤危险。 操作设备时必须确保切断电源。
	ÖNEMLİ DİKKAT	ОСТОРОЖНО	小心
	Cihazın güvenli çalışması ancak sertifikalı bileşenler kullanılması halinde garanti edilebilir.	Безопасность работы устройства гарантируется только при использовании сертифицированных компонентов.	只有使用经过认证的部件才能保证设备的正常运转。

<p>Technical Assistance: Telephone: +49 (911) 895-5900 (8° - 17° CET) Fax: +49 (911) 895-5907 E-mail: technical-assistance@siemens.com Internet: www.siemens.com/industrial-controls/technical-assistance</p>	<p>SIEMENS AG Technical Assistance Würzburger Str. 121 D-90766 Fürth</p>
---	--

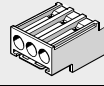
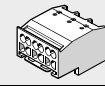
DE	Montage / Anschließen	ES	Montaje / Conexión	TR	Montaj / Bağlantı
EN	Assembly / Connect	IT	Montaggio / Collegamento	PY	Монтаж / Подключение
FR	Montage / Branchement	PT	Montagem / Conexão	中文	安装 / 连接

- 
 1. U = 0 V
 2. a, b, c, d



	3UG4513-1...	3UG4513-2...
		
	 0,8 ... 1,2 Nm (7 to 10,3 lb in) PZ2 (Ø 5 ... 6 mm)	 Ø 3,0 x 0,5 [mm]
	1 x (0,5 ... 4) mm ² 2 x (0,5 ... 2,5) mm ²	2 x (0,25 ... 1,5) mm ²
	—	2 x (0,25 ... 1,5) mm ²
	1 x (0,5 ... 2,5) mm ² 2 x (0,5 ... 1,5) mm ²	2 x (0,25 ... 1,5) mm ²
AWG	2 x (20 to 14)	2 x (24 to 16)

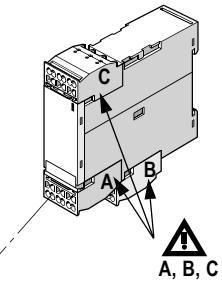
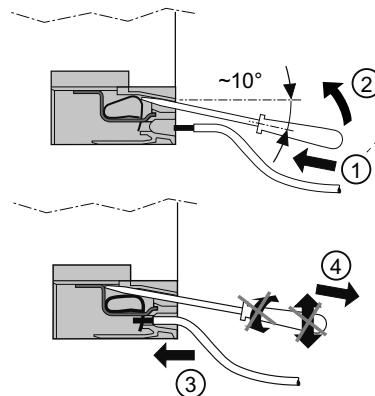
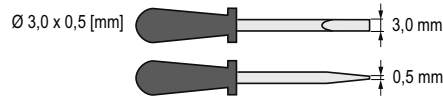

DE	Kodiert
EN	Coded
FR	Codé
ES	Cifrado
IT	Codificato
PT	Codificado
TR	Kodlanmış
PY	Кодировки
中文	带编码的

3UG4513

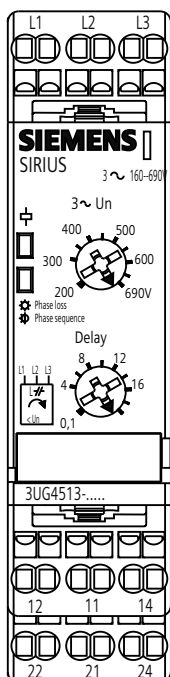

DE	Funktionsdiagramme	ES	Diagramas de funcionamiento	TR	Fonksiyon diyagramları
EN	Functional diagrams	IT	Diagrammi funzionali	PY	Функциональные диаграммы
FR	Diagrammes fonctionnels	PT	Diagramas funcionais	中文	功能图表

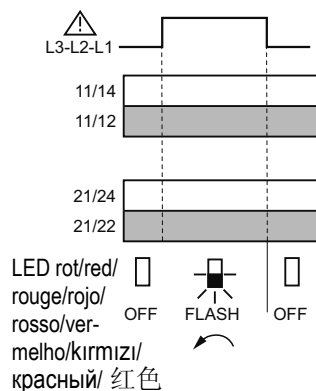
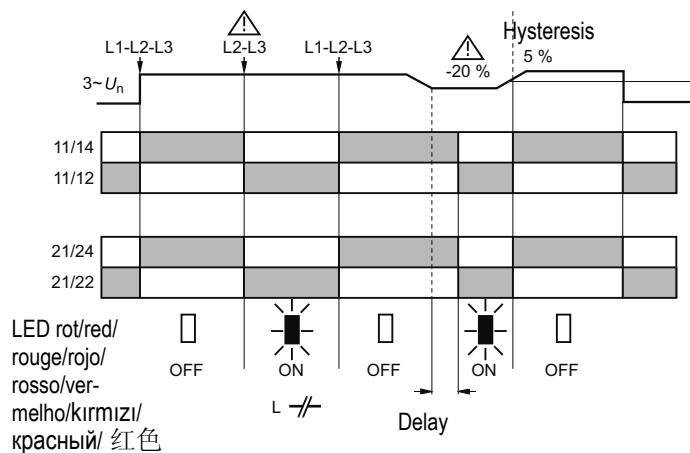

DE	Geräteschaltplan	ES	Esquema de conexiones	TR	Cihaz devre planı
EN	Device circuit diagram	IT	Schema delle connessioni	PY	Принципиальная схема
FR	Schéma des connexions	PT	Esquema elétrico do equipamento	中文	功能图表

3UG4513-.BR20

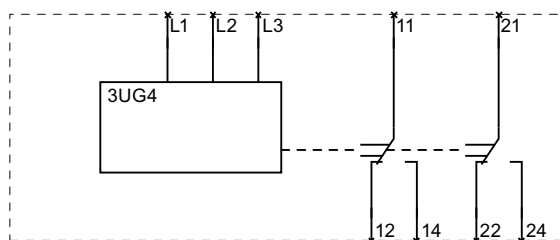

DE	Maßzeichnungen (Angaben in mm)	ES	Dibujos dimensionales (medidas en mm)	TR	Ölçü resimleri (Bilgiler mm olarak)
EN	Dimension drawings (all dimensions in mm)	IT	Disegni quotati (indicazioni in mm)	РУ	Габаритные чертежи (Все размеры в мм)
FR	Encombremments (indications en mm)	PT	Desenhos cotados (dimensões em mm)	中文	尺寸图 (单位: mm)

3UG4513-BR20

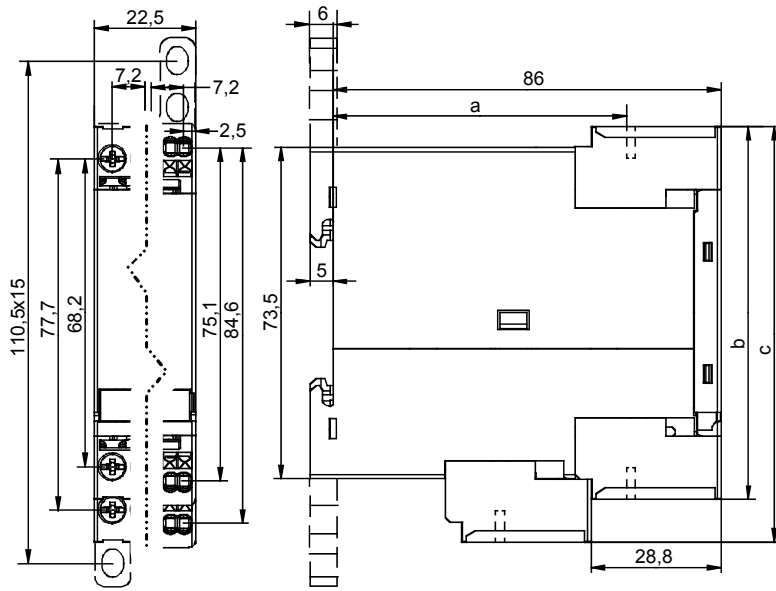

	a	b	c
3UG4513-1BR20	65	82,6	92,2
3UG4513-2BR20	—	84,4	93,9

	DE	3ZX1012-0UG40-0AB0	www.siemens.de/industrial-controls/support
	EN	3ZX1012-0UG40-0AC0	www.siemens.com/industrial-controls/support
	FR	3ZX1012-0UG40-0AD0	www.siemens.com/industrial-controls/support
	ES	3ZX1012-0UG40-0AE0	www.siemens.com/industrial-controls/support