

SIEMENS

Motorantrieb mit Federspeicher (mit mechanischem und elektrischem Abruf)
 Stored Energy Operator (with mechanical and electrical closing)
 Commande motorisée à accumulation d'énergie (avec déclencheur électrique et mécanique)
 Accionamiento motorizado con acumulador de resorte (con liberación mecánica y eléctrica)
 Comando motorizzato a molle (con richiamo meccanico ed elettrico)
 Acionamento motorizado com acumulador de molas (com disparador mecânico e elétrico)
 Yaylı akümülatörlü motor tahriği (mekanik ve elektrikli çağrı sistemli)
 Электропривод с пружинным энергоаккумулятором
 (с механическим и электрическим запросом)
 带弹力存储器的电动机机构 (带机械和电动轮询)

3VL9300-3M.00

for SENTRON
 VL160X - VL250



IEC / EN 60947

Betriebsanleitung Operating Instructions Instructions de service Instructivo Istruzioni operative
 Instruções de Serviço İşletme kılavuzu Руководство по эксплуатации 使用说明

	Deutsch	English	Français
	Vor der Installation, dem Betrieb oder der Wartung des Geräts muss diese Anleitung gelesen und verstanden werden.	Read and understand these instructions before installing, operating, or maintaining the equipment.	Ne pas installer, utiliser ou intervenir sur cet équipement avant d'avoir lu et assimilé les présentes instructions et notamment les conseils de sécurité et mises en garde qui y figurent.
	⚠ GEFÄHR	⚠ DANGER	⚠ DANGER
	Gefährliche Spannung. Lebensgefahr oder schwere Verletzungsgefahr. Vor Beginn der Arbeiten Anlage und Gerät spannungsfrei schalten.	Hazardous voltage. Will cause death or serious injury. Turn off and lock out all power supplying this device before working on this device.	Tension électrique. Danger de mort ou risque de blessures graves. Mettre hors tension avant d'intervenir sur l'appareil.
	VORSICHT	CAUTION	PRUDENCE
	Eine sichere Gerätefunktion ist nur mit zertifizierten Komponenten gewährleistet.	Reliable functioning of the equipment is only ensured with certified components.	La sécurité de fonctionnement de l'appareil n'est garantie qu'avec des composants certifiés.
	Español	Italiano	Português
	Leer y comprender este instructivo antes de la instalación, operación o mantenimiento del equipo.	Leggere con attenzione queste istruzioni prima di installare, utilizzare o eseguire manutenzione su questa apparecchiatura.	Ler e compreender estas instruções antes da instalação, operação ou manutenção do equipamento.
	⚠ PELIGRO	⚠ PERICOLO	⚠ PERIGO
	Tensión peligrosa. Puede causar la muerte o lesiones graves. Desconectar la alimentación eléctrica antes de trabajar en el equipo.	Tensione pericolosa. Può provocare morte o lesioni gravi. Scollegare l'alimentazione prima di eseguire interventi sull'apparecchiatura.	Tensão perigosa. Perigo de morte ou ferimentos graves. Desligue a alimentação elétrica e proteja contra o religamento, antes de iniciar o trabalho no equipamento.
	PRECAUCIÓN	CAUTELA	CUIDADO
	El funcionamiento seguro del aparato sólo está garantizado con componentes certificados.	Il funzionamento sicuro dell'apparecchiatura è garantito soltanto con componenti certificati.	O funcionamento seguro do aparelho apenas pode ser garantido se forem utilizados os componentes certificados.
	Türkçe	Русский	中文
	Cihazın kurulumundan, çalıştırılmasından veya bakıma tabi tutulmasından önce, bu kılavuzun okunmuş ve anlaşılması gerekmektedir.	Перед установкой, вводом в эксплуатацию или обслуживанием устройства необходимо прочесть и понять данное руководство.	安装、使用和维修本设备前必须先阅读并理解本说明。
	⚠ TEHLİKE	⚠ ОПАСНО	⚠ 危险
	Tehlikeli gerilim. Ölüm tehlikesi veya ağır yaralanma tehlikesi. Çalışmalara başlamadan önce, sistemin ve cihazın gerilim beslemesini kapatınız.	Опасное напряжение. Опасность для жизни или возможность тяжелых травм. Перед началом работ отключить подачу питания к установке и к устройству.	危险电压。可能导致生命危险或重伤危险。 操作设备时必须确保切断电源。
	ÖNEMLİ DİKKAT	ОСТОРОЖНО	小心
	Cihazın güvenli çalışması ancak sertifikalı bileşenler kullanılması halinde garanti edilebilir.	Безопасность работы устройства гарантируется только при использовании сертифицированных компонентов.	只有使用经过认证的部件才能保证设备的正常运转。

Technical Support: Internet: <http://www.siemens.com/lowvoltage/technical-support>

DE	Lieferumfang	EN	Quantity of delivery	FR	Composition de la fourniture
ES	Alcance del suministro	IT	Configurazione di fornitura	PT	Âmbito do fornecimento
TR	Teslimat hacmi	PY	Комплект поставки	中文	供货范围

3VL9300-3MJ00
 3VL9300-3ML00
 3VL9300-3MS00
 3VL9300-3MN00
 3VL9300-3MQ00

M6 x 35 mm

VL160X

VL250 / VL160

M4 x 6 mm

3VL9300-3MJ00 = 24 VDC
 3VL9300-3ML00 = 42 - 48 V AC / DC
 3VL9300-3MS00 = 60 V AC / DC
 3VL9300-3MN00 = 110 - 127 V AC / DC
 3VL9300-3MQ00 = 220 - 250 V AC / DC

DE	Notwendige Werkzeuge für Montage
EN	Necessary assembly tools
FR	Outils nécessaires pour le montage
ES	Herramientas requeridas para el montaje
IT	Utensili necessari per il montaggio
PT	Ferramentas necessárias para a montagem
TR	Montaj için gerekli aletler
PY	Инструменты, необходимые для монтажа
中文	安装所需工具

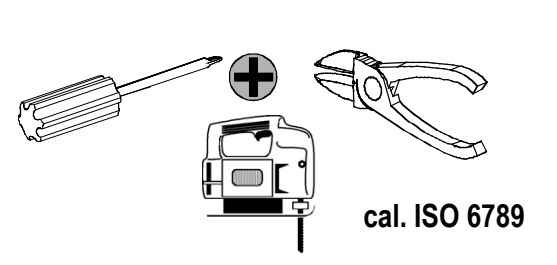

DE	Montage	EN	Assembly	FR	Montage
ES	Montaje	IT	Montaggio	PT	Montagem
TR	Montaj	PY	Монтаж	中文	安装

1

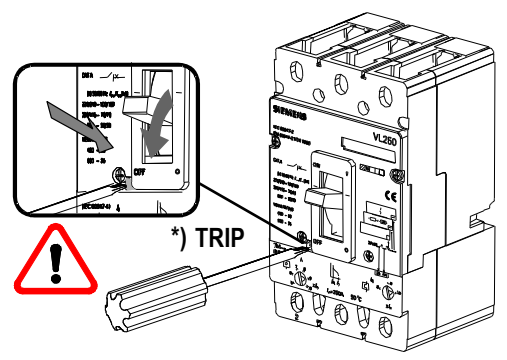

2

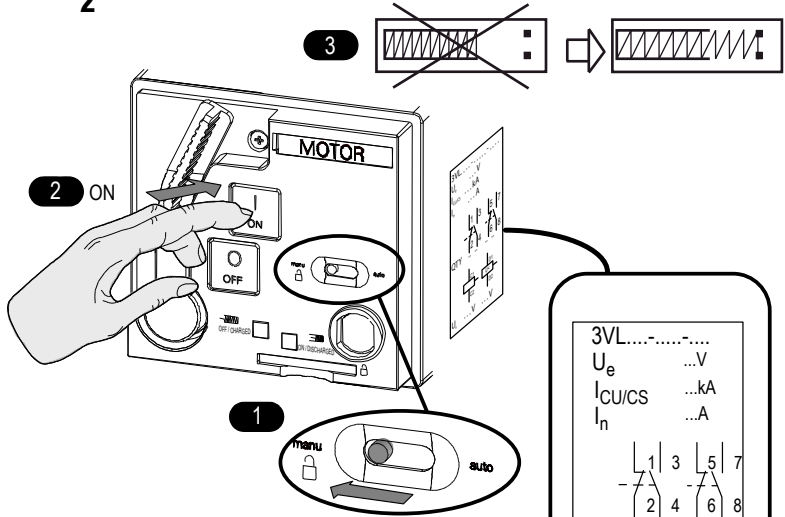

*)

DE	Auslösen
EN	Trip
FR	Déclencher
ES	Disparar
IT	Sganciare
PT	Disparar
TR	Çözme
PY	Размыкание
中文	脱扣

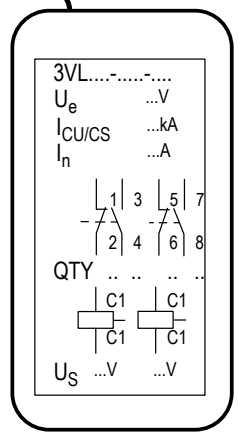

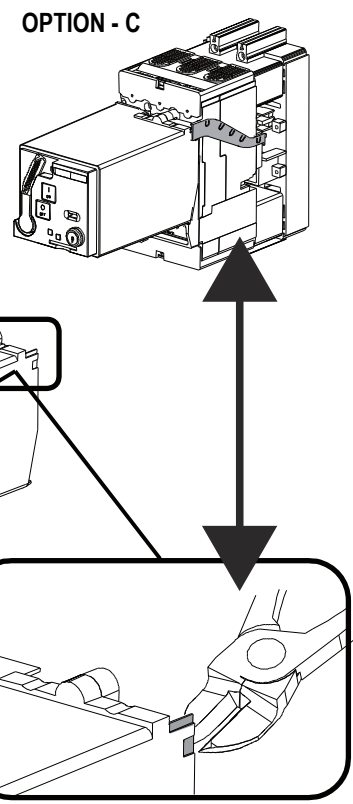
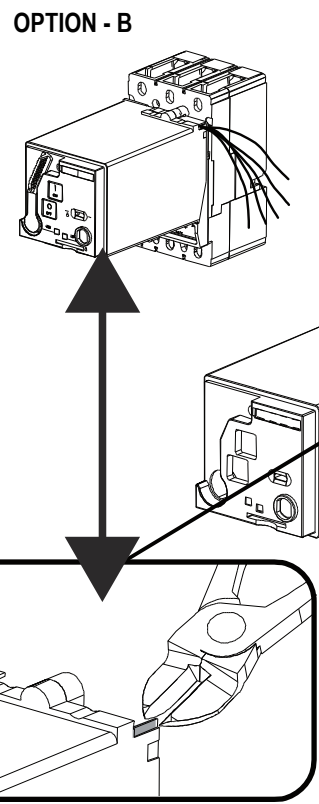
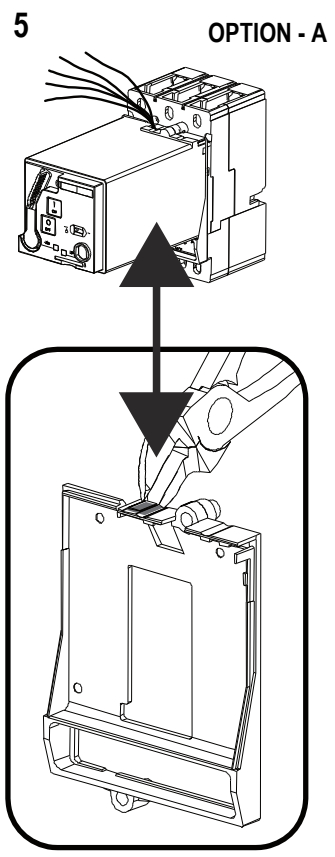
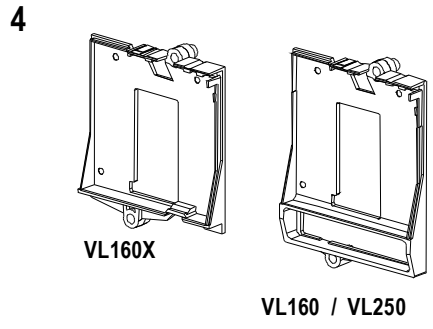
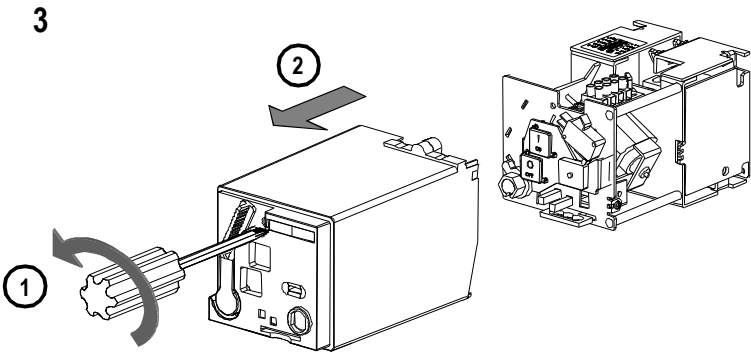

Deutsch	Option	English	Option	Français	Option
Español	Opción	Italiano	Opzione	Português	Opção
Türkçe	Opsiyon	Русский	Опция	中文	选项

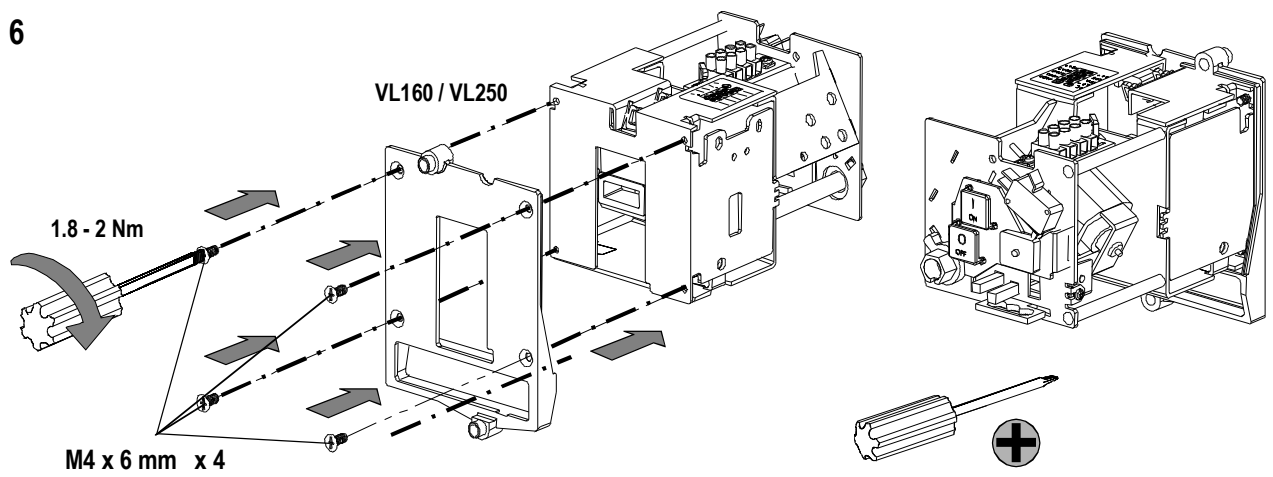

7

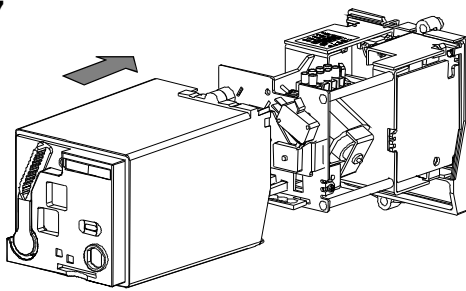

8

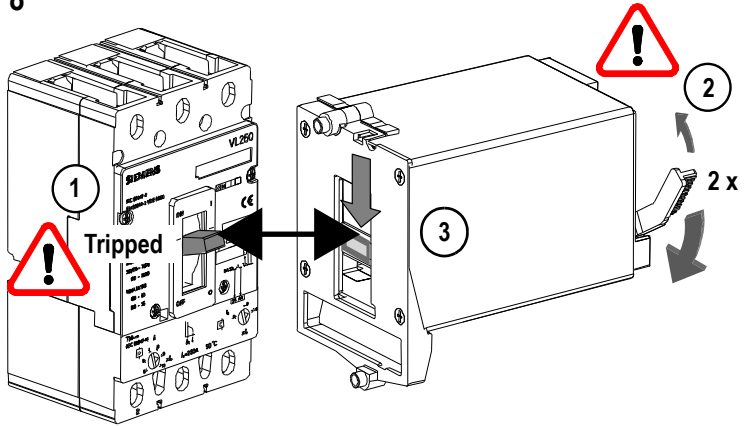

DE	EN	FR	ES	IT	PT	TR	PY	中文
Ausgelöst	Tripped	Déclenché	Disparado	Sganciato	Disparado	Çözülmüş durum	Разомкнuto	断开

9

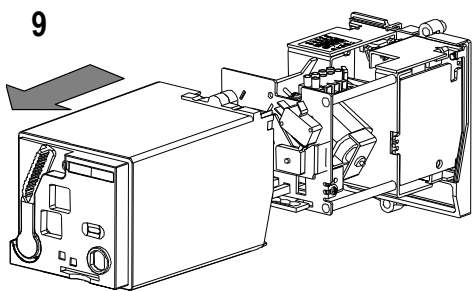

10

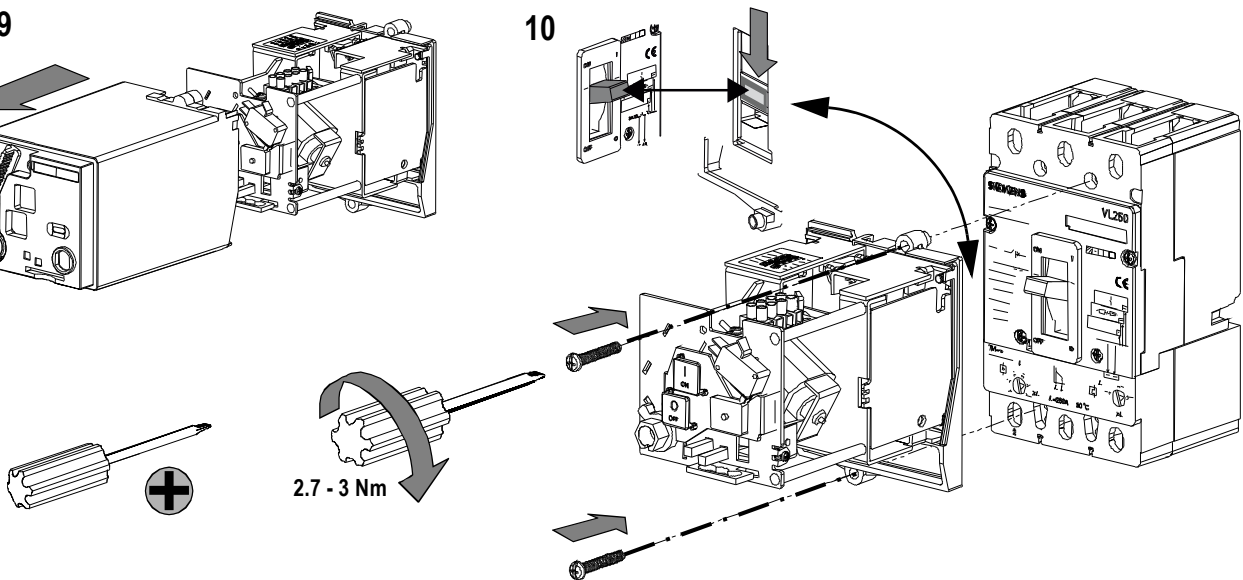

11

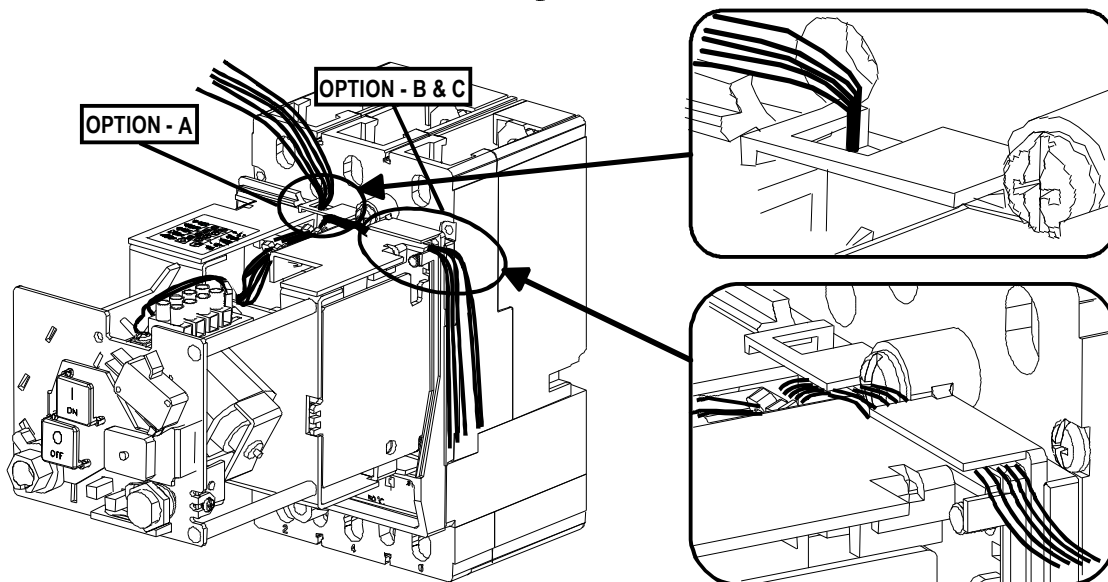

Deutsch	Option	English	Option	Français	Option
Español	Opción	Italiano	Opzione	Português	Opção
Türkçe	Opsiyon	Русский	Опция	中文	选项

Deutsch	English	Français	Español	Italiano	Português	Türkçe	Русский	中文
Motorantrieb mit Speicher	Stored energy operator	Commande motorisée à accumulation	Accionamiento motorizado con acumulador	Azionamento motore con memoria	Acionamento do motor com acumulador	Akümülatörlü motor tahriği	Электропривод с аккумулятором энергии	带存储器的电机驱动
Hebel spannen	Charge manual handle	Armer levier	Cargar con palanca	Caricare la leva	Tensionar alavanca	Manivelayı çekerek sabitleme	Потянуть рычаг	操纵杆拉紧
Sperre	Lock out	Verrou	Bloqueo	Blocco	Bloqueio	Kilit	Стопор	锁定
LS offen	CB open	DJ ouvert	Interr. abierto	IA aperto	LS (disjuntor) aberto	LS açık	Фотодатчик откр	断路器断开的
LS geschlossen	CB closed	DJ fermé	Interr. cerrado	IA chiuso	LS (disjuntor) fechado	LS kapalı	Фотодатчик закрыт	断路器接通的
Alarmschalter	Alarm switch	Contact d'alarme	Bloque de alarma	Interruttore di allarme	Chave do alarme	Alarm şalteri	Выключатель аварийного сигнала	报警开关
AUS	OFF	OFF	DES	OFF	DESLIGAR	KAPALI	ВыКЛ	关断
EIN	ON	ON	CON	ON	LIGAR	AÇIK	ВКЛ	接通

12a

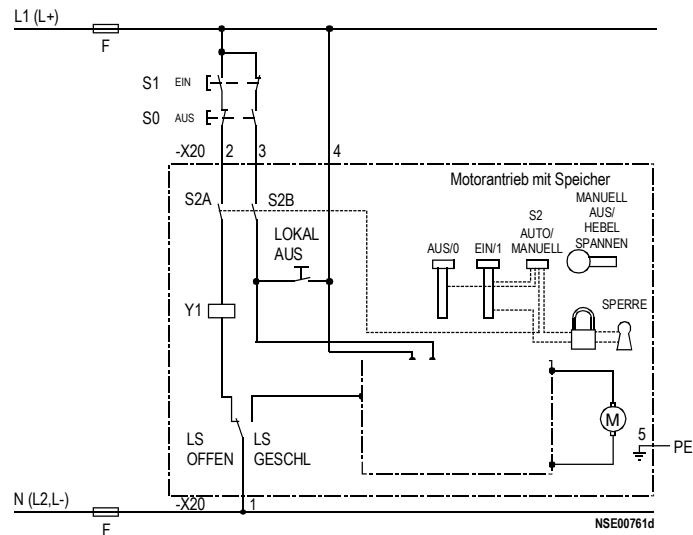

12b

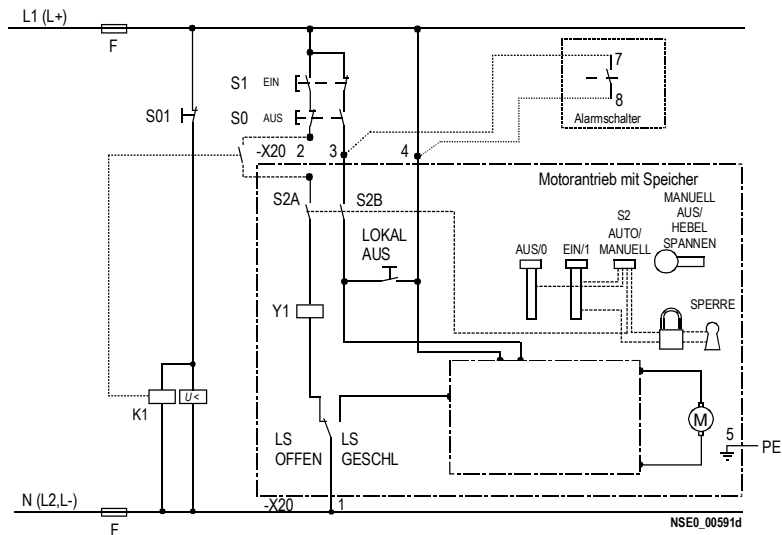

	Deutsch	English	Français	Español	Italiano	Português	Türkçe	Русский	中文
S0	AUS (kunden-seitig vorzusehen)	OFF (to be provided by customer)	ARRET (à prévoir par le client)	DES (por cuenta del cliente)	OFF (da parte del cliente)	DESLIGAR (por parte do cliente)	KAPALI (müşteri tarafından belirlenir)	ВыКП (должно предусмотрено пользователем)	关断 (客户规定)
S1	EIN (kunden-seitig vorzusehen)	ON (to be provided by customer)	MARCHE (à prévoir par le client)	CON (por cuenta del cliente)	ON (da parte del cliente)	LIGAR (por parte do cliente)	AÇIK (müşteri tarafından belirlenir)	ВКП (должно предусмотрено пользователем)	接通 (客户规定)
S2	Wahlschalter AUTO/manuell	Selector switch AUTO/manual	Interrupteur de sélection AUTO/manuel	Seleccionador AUTO/manual	Selettore AUTO/manuale	Int. de seleção AUTO/manual	Seçim şalteri OTOMATİK/manüel	Переключатель АВТО/ручной	选择开关 自动 / 手动
Y1	Einschaltmagnet	Closing solenoid	Aimant de commutation	Electroimán de conexión	Magnete di accensione	Ímã de ligação	Açma mıknatısı	Включающий магнит	合闸电磁铁
F1	Sicherung im Steuerstromkreis	Control circuit fuse	Fusible dans le circuit de commande	Fusible circuito de mando	Fusibile nel circuito di comando	Fusível no circuito de comando	Kumanda akım devresinde sigorta	Предохранитель в контуре управляющего тока	在控制电路中的熔断器
F2	Option	Option	Option	Opción	Opzione	Opção	Opsiyon	Опция	选择项
S01	Fernkommando (kundenseitig vorzusehen)	Remote command (to be provided by customer)	Télécommande (à prévoir par le client)	Mando remoto (por cuenta del cliente)	Comando a distanza (da parte del cliente)	Controle remoto (por parte do cliente)	Uzaktan kumanda (müşteri tarafından belirlenir)	Дистанционная команда (должно предусмотрено пользователем)	远程指令 (客户规定)
K1	Hilfsschutz (kundenseitig vorzusehen)	Aux. contactor (to be provided by customer)	Contacteur aux. (à prévoir par le client)	Contacteur auxiliar (por cuenta del cliente)	Contactore ausiliario (da parte del cliente)	Contactor auxiliar (por parte do cliente)	Yardımcı elektro manyetik şalter (müşteri tarafından belirlenir)	Вспомогательное реле (должно предусмотрено пользователем)	辅助接触器 (客户规定)

Typ / type / tipo / Tip / Тип		VL160X / VL160 / VL250						
Sicherungen / fuses / fusibles / fusibile / fusível / Sigortalar / Предохранители								
Bemessungssteuerspeisespannung U_S / Rated control supply voltage U_S / Tension assignée d'alimentation de commande U_S / Tensión asignada de alimentación de mando U_S / Tensione nominale di alimentazione del comando U_S / Tensão de alimentação medida U_S / Ölçüm kumanda besleme gerilimi U_S / Номинальное управляющее напряжение U_S / 額定控制馈电电压 U_S		50 - 60 Hz AC	V		48	60	110/127	230/250
		DC	V	24	48	60	110/127	230/250
Sicherung (träge) / Fuse (time-lag) / Fusible (retardé) / Fusible (lento) / Fusibile (ritardato) / Fusível (de ação lenta) / Sigorta (yavaş) / Предохранитель (инерционный) / 熔断器 (延时的)								
Leitungsschutzschalter, C-Charakteristik / Miniature circuit-breaker (C characteristic) / Disjoncteur (caractéristique C) / Automático magnetotérmico (característica C) / Interruttore automatico (caratteristica C) / Interruptor automático (caraterística C) / Hat koruma şalteri, C- Karakteristik / Линейный защитный автомат с C-характеристикой 线路保护开关, C 特性			A		10			2

13

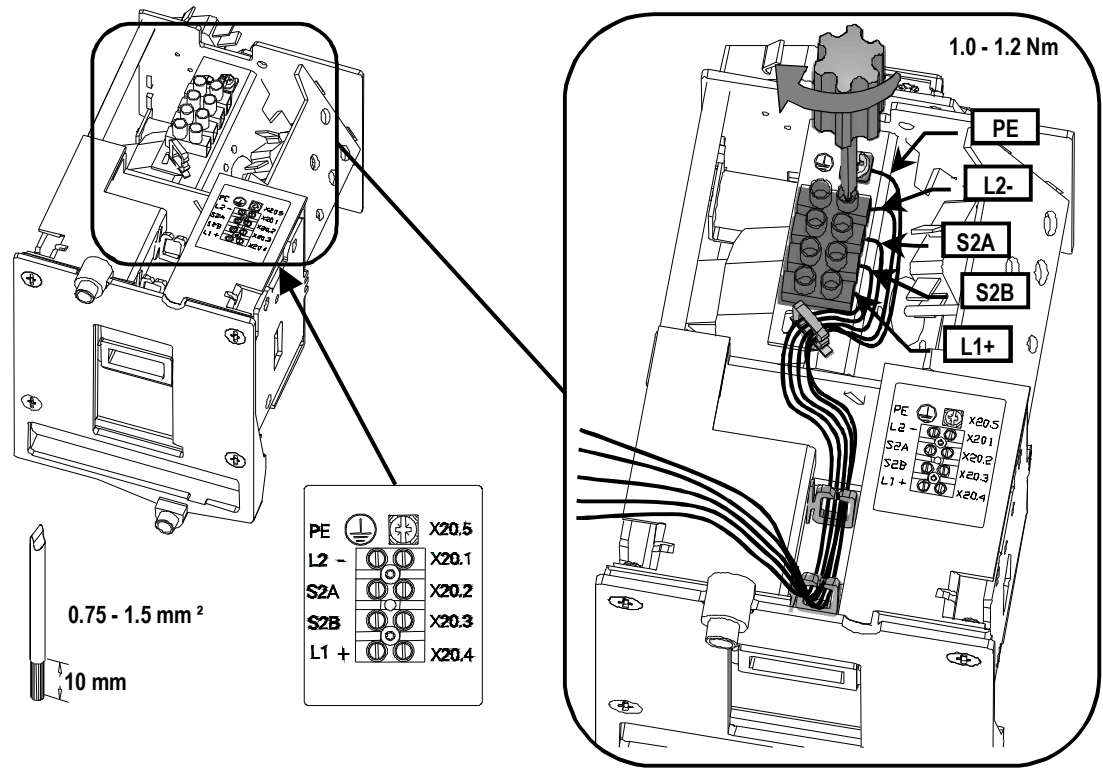

14

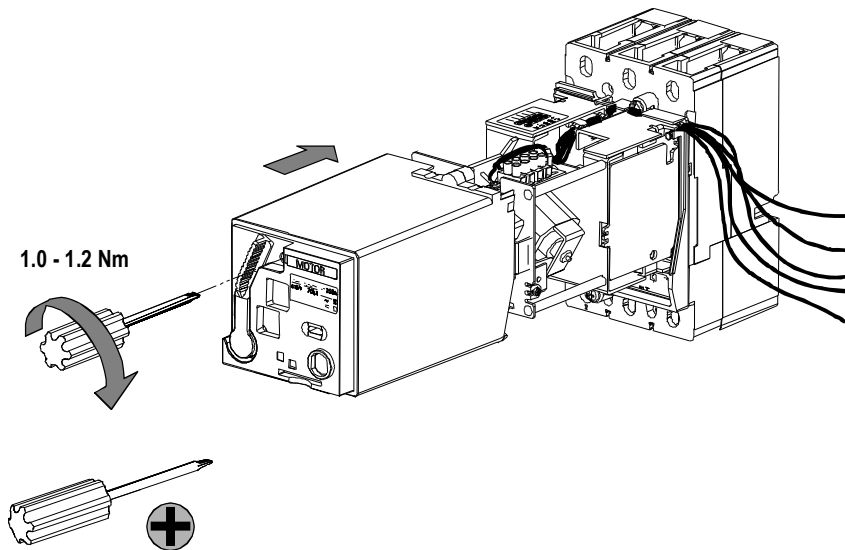

15

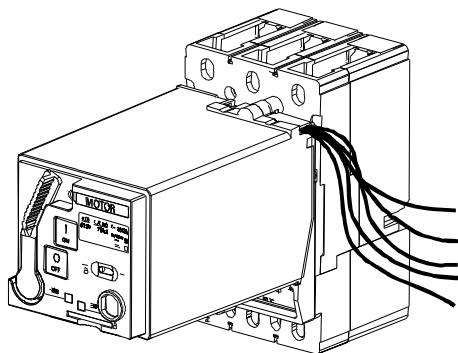

16

Plug-in-OPTION C

OPTION - C

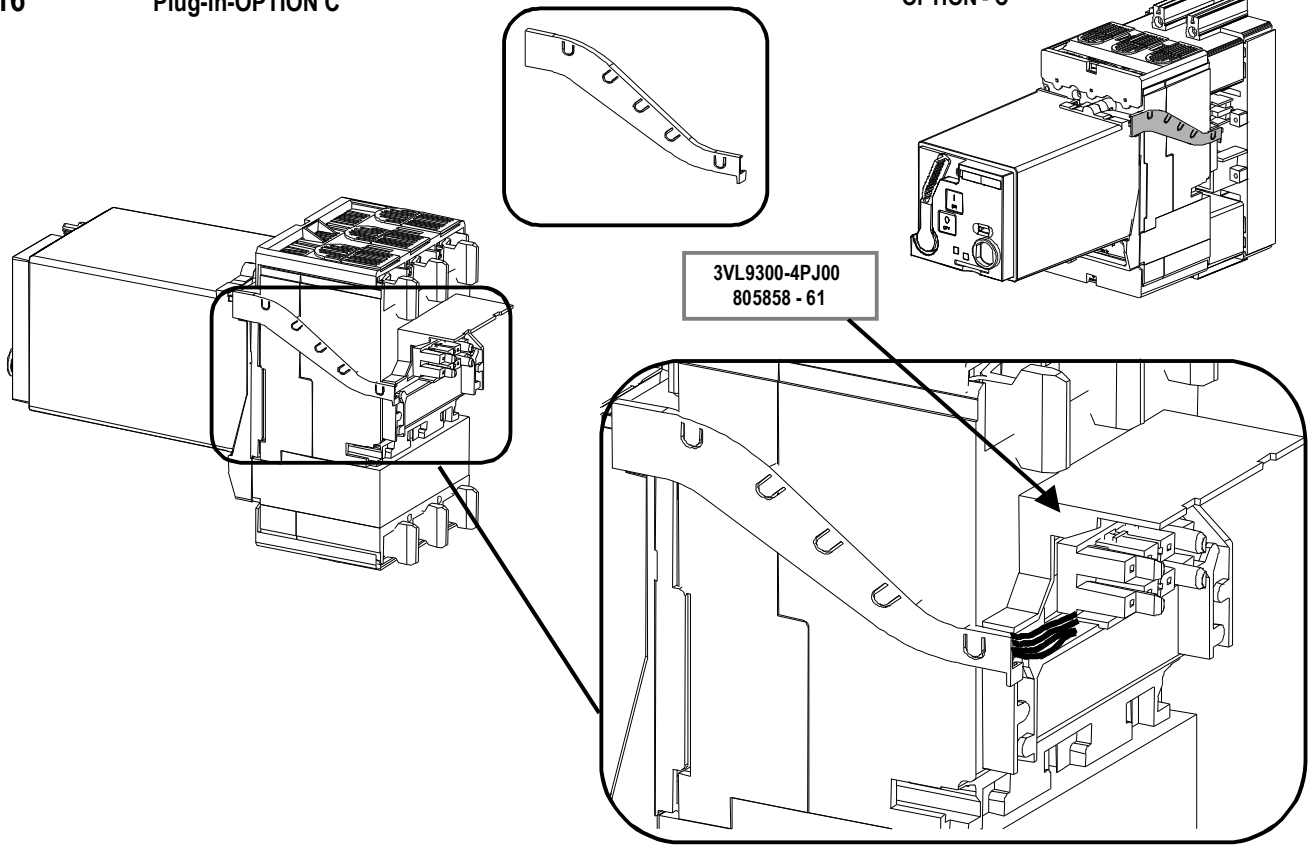

Deutsch	Option	English	Option	Français	Option
Español	Opción	Italiano	Opzione	Português	Opção
Türkçe	Opsiyon	Русский	Опция	中文	选项

17

Plug-in-OPTION C

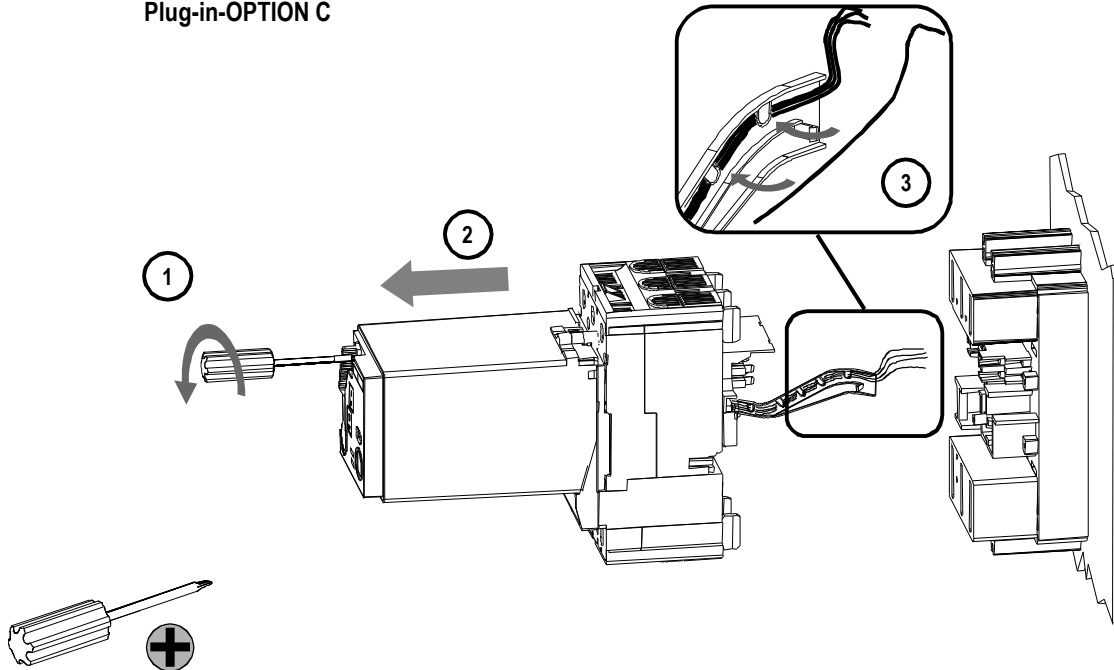

18

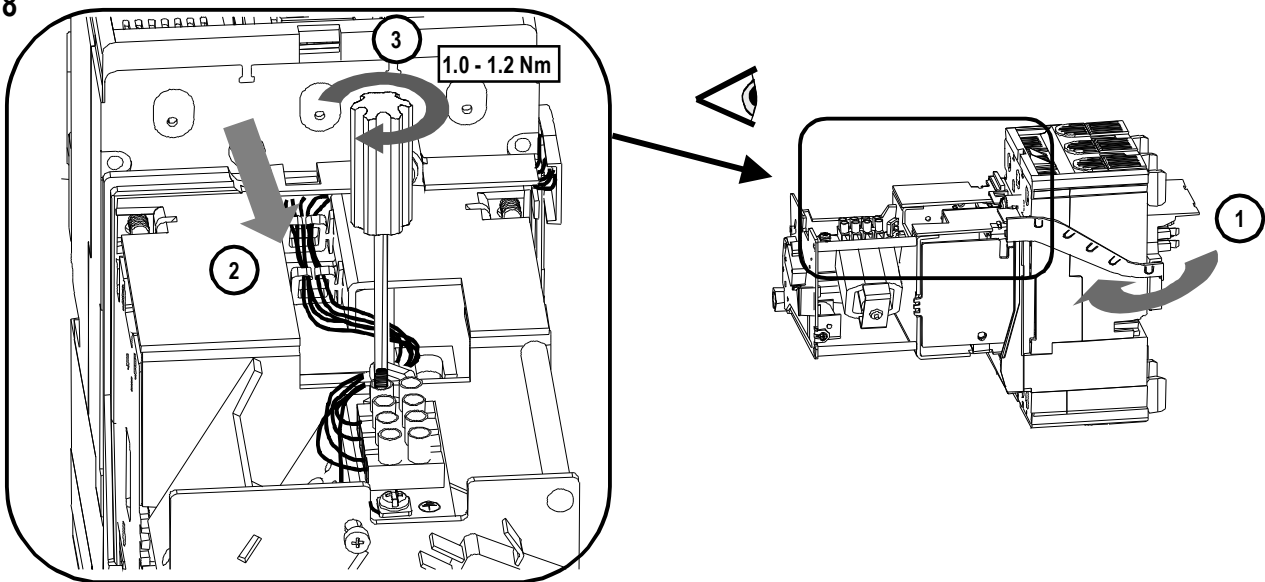

19

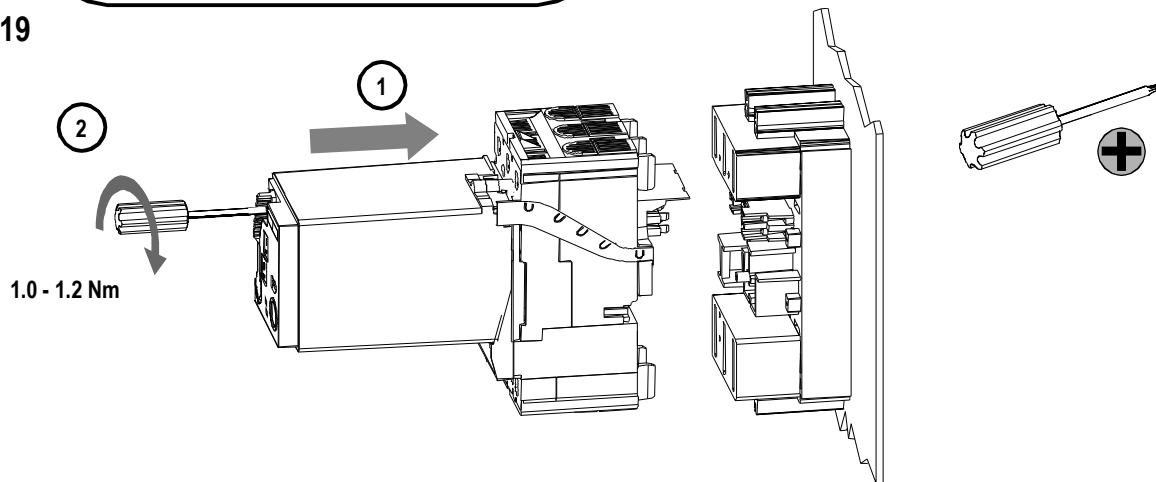

20

TEST
Manual / Emergency OFF*)

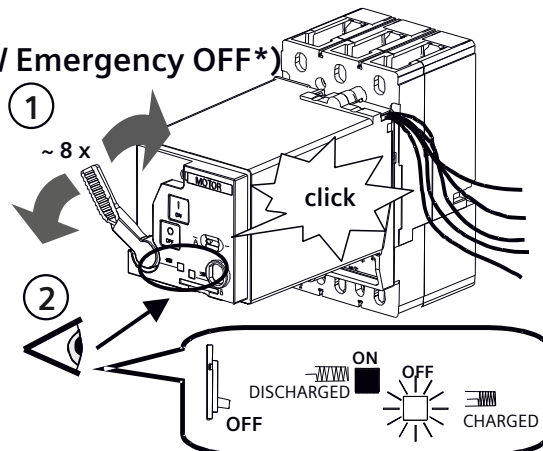

21

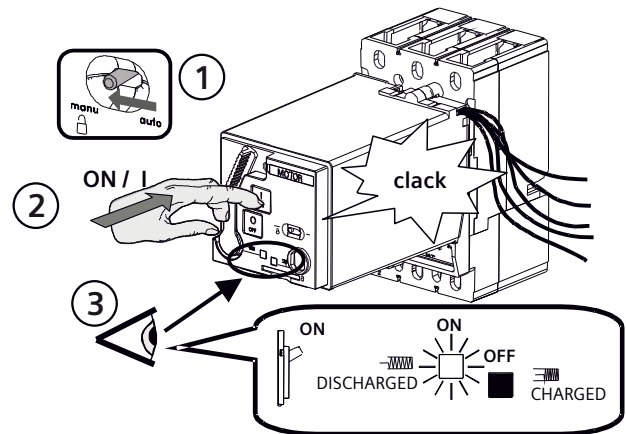

DE	NOT-AUS	EN	EMERGENCY OFF	FR	Arrêt d'urgence
ES	Parada de emergencia	IT	Emergenza	PT	Desativação de emergência
TR	ACIL STOP	РУ	Аварийное выключение	中文	紧急停车

22a

TEST

AUTO

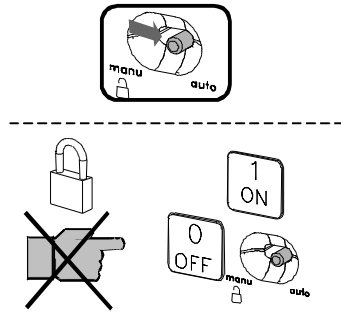

22b

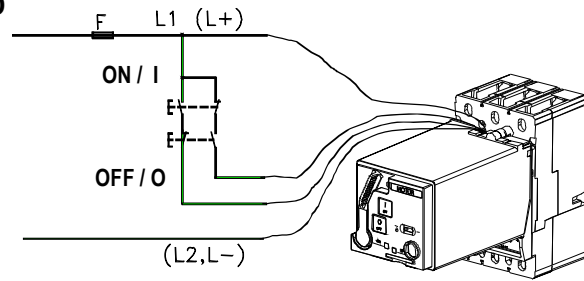

22c

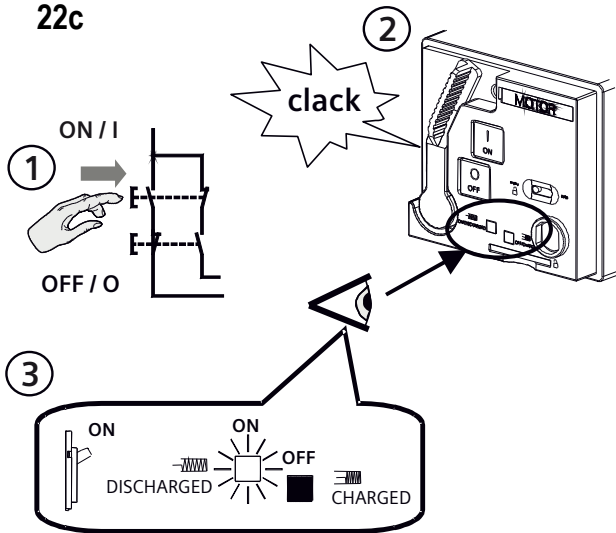

22d

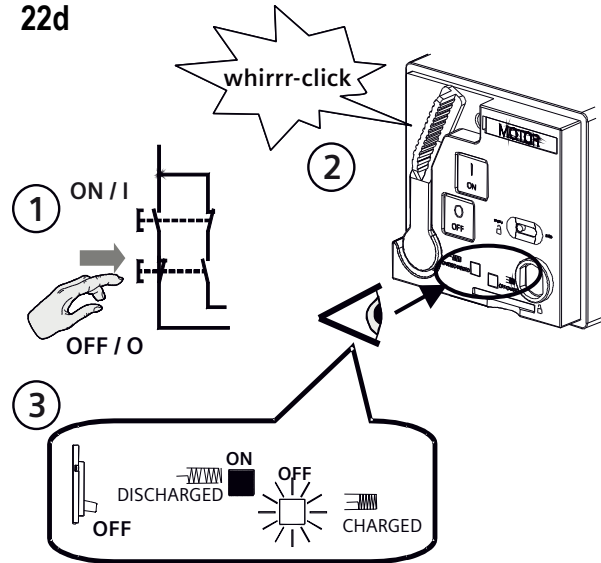

23a

OPTION*):

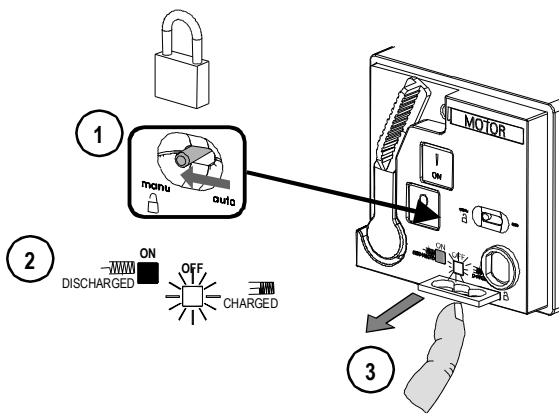

23b

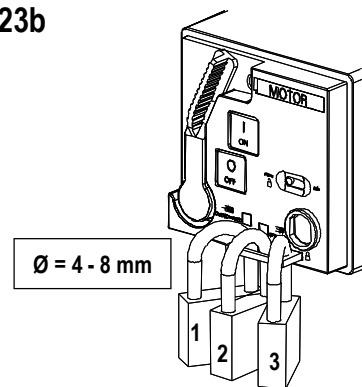

Deutsch	Option	English	Option	Français	Option
Español	Opción	Italiano	Opzione	Português	Opção
Türkçe	Opsiyon	Русский	Опция	中文	选项

24

Manual TRIP - OPTION *)

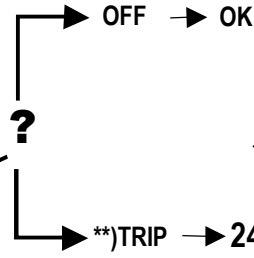
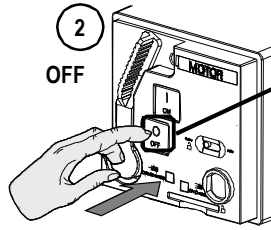
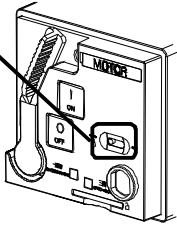
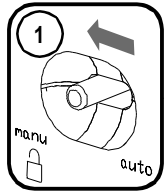

24.1

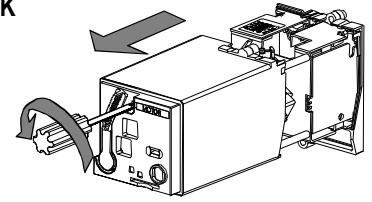

24.2

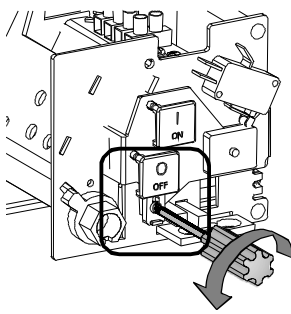

24.3

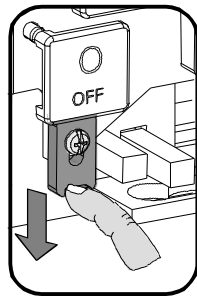

24.4

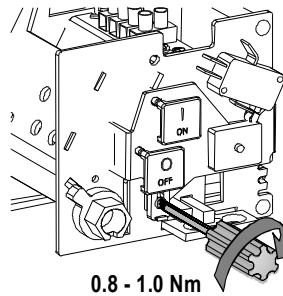

0.8 - 1.0 Nm

24.5

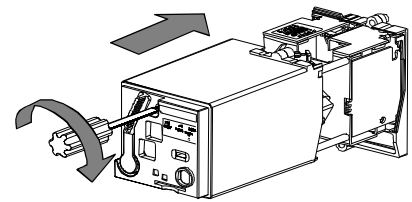

1.0 - 1.2 Nm

Deutsch	English	Français	Español	Italiano	Português	Türkçe	Русский	中文
*) Option	Option	Option	Opción	Opzione	Opção	Opsiyon	Опция	选项
**) Auslösen	Trip	Déclencher	Disparar	Sganciare	Disparar	Çözme	Размыкание	脱扣

25

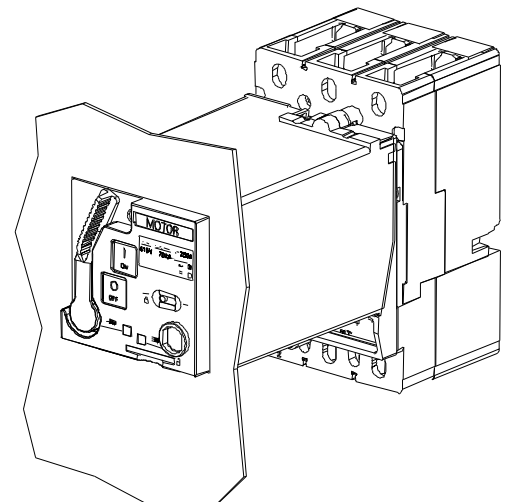
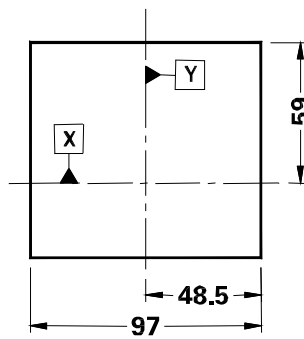
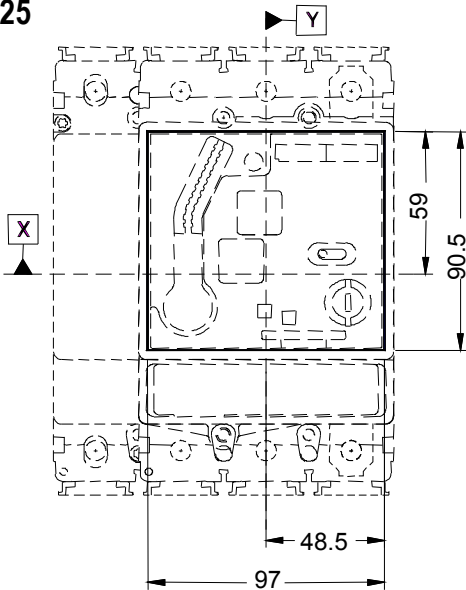

DE	Weitere Informationen finden Sie im 3VL-Handbuch im Internet unter: www.siemens.com/lowvoltage/manuals (nur in Deutsch und Englisch)
EN	Further information can be found in the 3VL manual on the internet at www.siemens.com/lowvoltage/manuals (only in German and English)
FR	Vous trouverez des informations supplémentaires dans le manuel 3VL sur le site Internet www.siemens.com/lowvoltage/manuals (seulement en allemand et en anglais)
ES	Para más información, consulte el manual 3VL que está disponible en nuestra página web www.siemens.com/lowvoltage/manuals (sólo en alemán e inglés)
IT	Ulteriori informazioni sono disponibili in Internet nel manuale 3VL su www.siemens.com/lowvoltage/manuals (solo in tedesco e in inglese)
PT	Mais informações encontram-se no manual 3VL na Internet, sob www.siemens.com/lowvoltage/manuals (somente em alemão e em inglês)
TR	Ayrıntılı bilgiyi aşağıdaki internet adresindeki 3VL kullanma kılavuzundan edinebilirsiniz: www.siemens.com/lowvoltage/manuals (sadece Almanca ve İngilizce olarak)
py	Дальнейшую информацию Вы сможете найти в инструкции по эксплуатации 3VL в интернете по адресу: www.siemens.com/lowvoltage/manuals (только на немецком и английском языке)
中文	其他相关信息参见 3VL 使用手册，请登陆互联网： www.siemens.com/lowvoltage/manuals （德、英文）