

SIEMENS

Motorantrieb mit Federspeicher (mit Hilfsschalter)

Stored Energy Operator (with auxiliary switch)

Commande motorisée à accumulation d'énergie (avec bloc contacts auxil.)

Accionamiento motorizado con acumulador (con interruptor auxiliar)

Azionamento motore con freno a molla (con interruttore ausiliario)

Acionamento motorizado com acumulador de molas (com chave auxiliar)

Yaylı akümülatörlü motor tahriği (yardımcı şalter ile)

Электропривод с пружинным энергоаккумулятором (со вспомогательным контактом)



带有弹簧储能器的电机传动装置 (具有辅助开关)

3VL9400-3M.00

3VL9600-3M.00

for Sentron
VL400 - VL800

SENTRON® VL CE

Betriebsanleitung Instruções de Serviço	Operating Instructions İşletme kılavuzu	Instructions de service Инструкция по эксплуатации	Instructivo 使用说明	Istruzioni operative
Deutsch		English		Français
Vor der Installation, dem Betrieb oder der Wartung des Geräts muss diese Anleitung gelesen und verstanden werden.		Read and understand these instructions before installing, operating, or maintaining the equipment.		Ne pas installer, utiliser ou intervenir sur cet équipement avant d'avoir lu et assimilé les présentes instructions et notamment les conseils de sécurité et mises en garde qui y figurent.
⚠ GEFÄHR		⚠ DANGER		⚠ DANGER
 Gefährliche Spannung. Lebensgefahr oder schwere Verletzungsgefahr. Vor Beginn der Arbeiten Anlage und Gerät spannungsfrei schalten.		Hazardous voltage. Will cause death or serious injury. Turn off and lock out all power supplying this device before working on this device.		Tension électrique Danger de mort ou risque de blessures graves. Mettre hors tension avant d'intervenir sur l'appareil.
VORSICHT		CAUTION		PRUDENCE
Eine sichere Gerätefunktion ist nur mit zertifizierten Komponenten gewährleistet!		Reliable functioning of the equipment is only ensured with certified components.		La sécurité de fonctionnement de l'appareil n'est garantie qu'avec des composants certifiés.
Español		Italiano		Português
Leer y comprender este instructivo antes de la instalación, operación o mantenimiento del equipo.		Leggere con attenzione queste istruzioni prima di installare, utilizzare o eseguire manutenzione su questa apparecchiatura.		Ler e compreender estas instruções antes da instalação, operação ou manutenção do equipamento.
⚠ PELIGRO		⚠ PERICOLO		⚠ PERIGO
 Tensión peligrosa. Puede causar la muerte o lesiones graves. Desconectar la alimentación eléctrica antes de trabajar en el equipo.		Tensione pericolosa. Può provocare morte o lesioni gravi. Scollegare l'alimentazione prima di eseguire interventi sull'apparechiatura.		Tensão perigosa. Perigo de morte ou ferimentos graves. Desligue a corrente antes de trabalhar no equipamento.
PRECAUCIÓN		CAUTELA		CUIDADO
El funcionamiento seguro del aparato sólo está garantizado con componentes certificados.		Il funzionamento sicuro dell'apparechiatura è garantito soltanto con componenti certificati.		O funcionamento seguro do aparelho apenas pode ser garantido se forem utilizados os componentes certificados.
Türkçe		Русский		中文
Cihazın kurulumundan, çalıştırılmasından veya bakıma tabi tutulmasından önce, bu kılavuz okunmuş ve anlaşılmış olmalıdır.		Перед установкой, вводом в эксплуатацию или обслуживанием устройства необходимо прочесть и понять данное руководство.		安装、使用和维修本设备前必须先阅读并理解本说明。
⚠ TEHLİKE		⚠ ОПАСНО		⚠ 危险
 Tehlikeli gerilim. Ölüm tehlikesi veya ağır yaralanma tehlikesi mevcuttur. Çalışmalara başlamadan önce, sistemin ve cihazın enerjisini kesiniz.		Опасное напряжение. Опасность для жизни или возможность тяжелых травм. Перед началом работ отключить подачу питания к установке и к устройству.		危险电压。可能导致生命危险或重伤危险。 操作设备时必须确保切断电源。
ÖNEMLİ DİKKAT		ОСТОРОЖНО		警告
Cihazın güvenli çalışması ancak sertifikalı bileşenler kullanılması halinde garanti edilebilir.		Безопасность работы устройства гарантировано только при использовании сертифицированных компонентов.		只有使用经过认证的部件才能保证设备的正常运转!
Technical Assistance:	Telephone: +49 (0) 911-895-5900 (8° - 17° CET) E-mail: technical-assistance@siemens.com Internet: www.siemens.de/lowvoltage/technical-assistance	Fax: +49 (0) 911-895-5907		
Technical Support:	Telephone: +49 (0) 180 50 50 222			

DE	Lieferumfang
EN	Quantity of delivery
FR	Composition de la fourniture
ES	Alcance del suministro
IT	Configurazione di fornitura
PT	Âmbito do fornecimento
TR	Teslimat hacmi
PY	Комплект поставки
中文	供货范围

DE	Notwendige Werkzeuge für Montage
EN	Necessary assembly tools
FR	Outils nécessaires pour le montage
ES	Herramientas requeridas para el montaje
IT	Utensili necessari per il montaggio
PT	Ferramentas necessárias para a montagem
TR	Montaj için gerekli aletler
PY	Инструменты, необходимые для монтажа
中文	安装所需工具

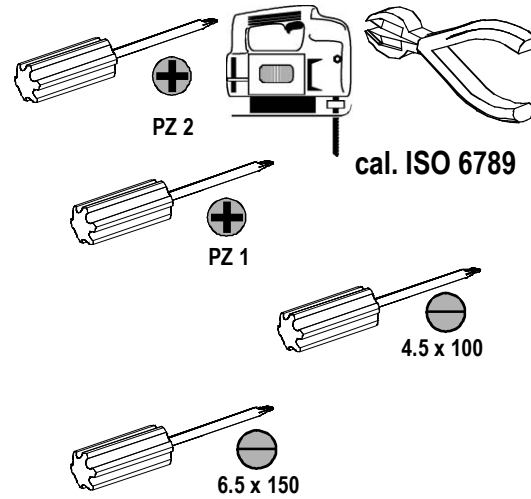
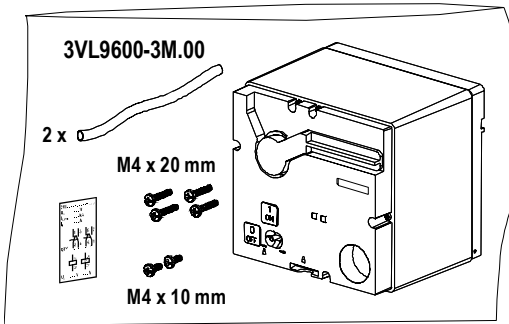
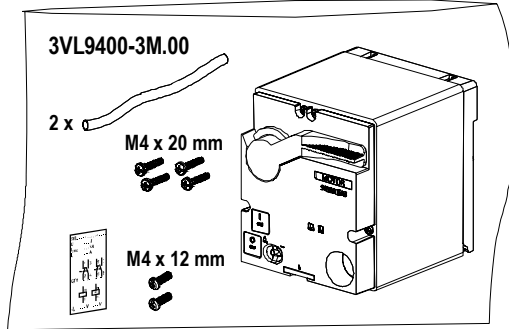

3VL94..-3MF00 = 24 V DC	3VL96..-3MF00 = 24 V DC
3VL94..-3MG00 = 42 - 48 V AC/DC	3VL96..-3MG00 = 42 - 48 V AC/DC
3VL94..-3MH00 = 60 V AC/DC	3VL96..-3MH00 = 60 V AC/DC
3VL94..-3MK00 = 110 - 127 V AC/DC	3VL96..-3MK00 = 110 - 127 V AC/DC
3VL94..-3MM00 = 220 - 250 V AC/DC	3VL96..-3MM00 = 220 - 250 V AC/DC

DE	Montage	EN	Assembly	FR	Montage
ES	Montaje	IT	Montaggio	PT	Montagem
TR	Montaj	PY	Монтаж	中文	安装

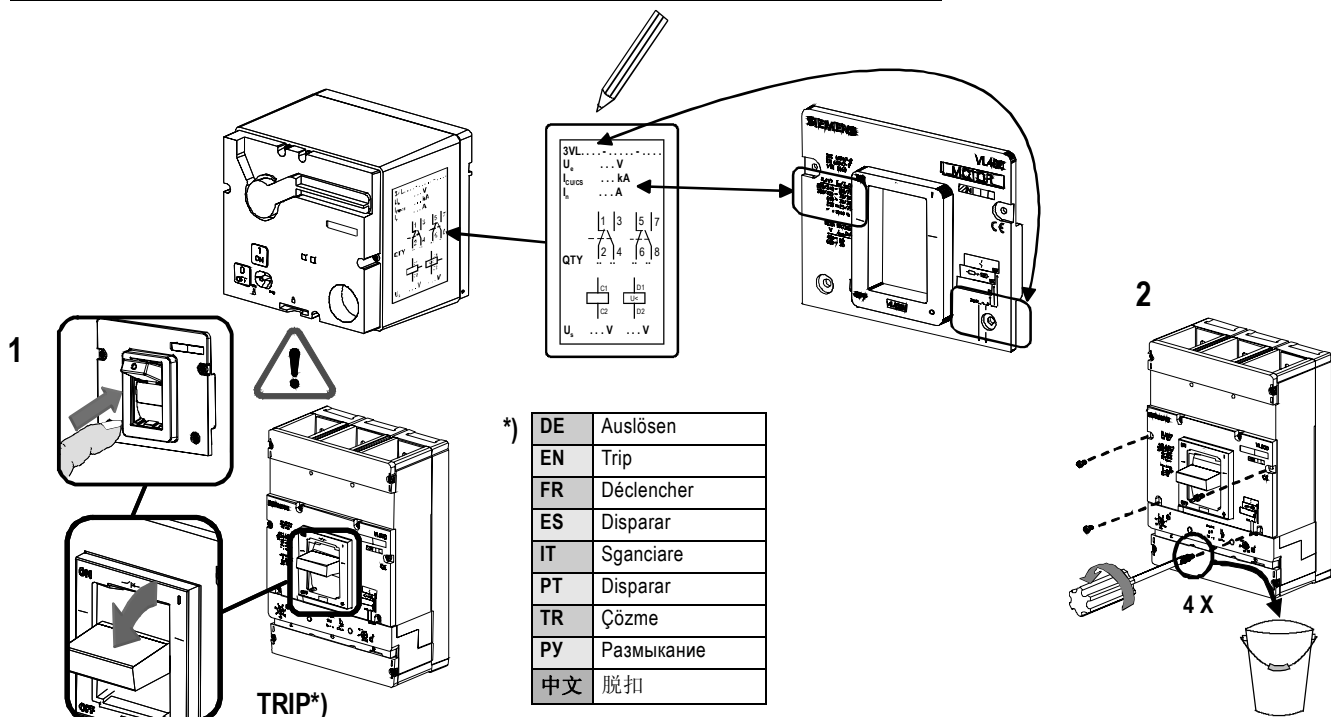

*) DE	Auslösen
EN	Trip
FR	Déclencher
ES	Disparar
IT	Sganciare
PT	Disparar
TR	Çözme
PY	Размыкание
中文	脱扣

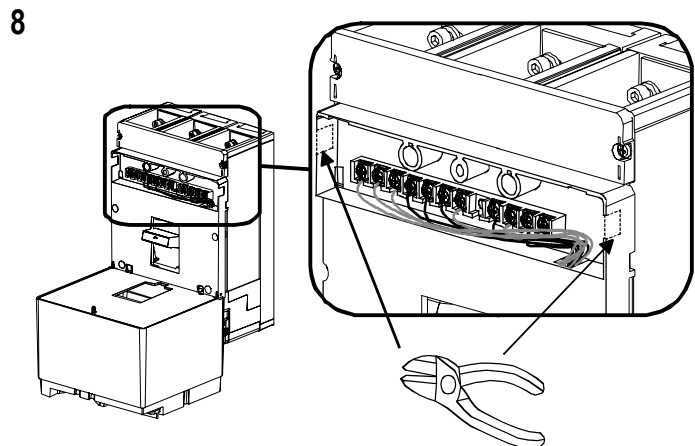
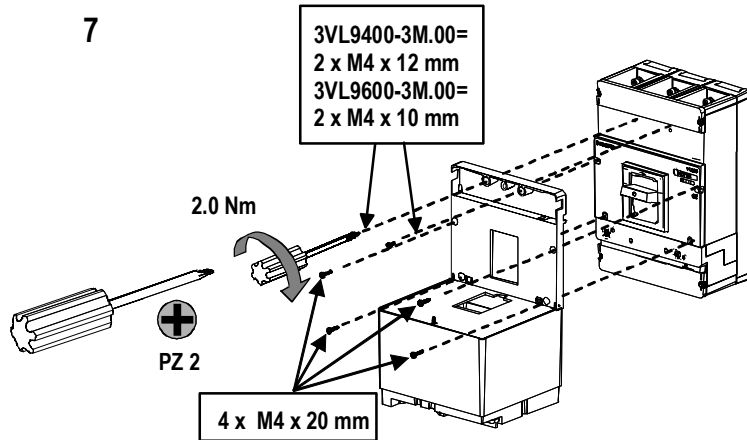
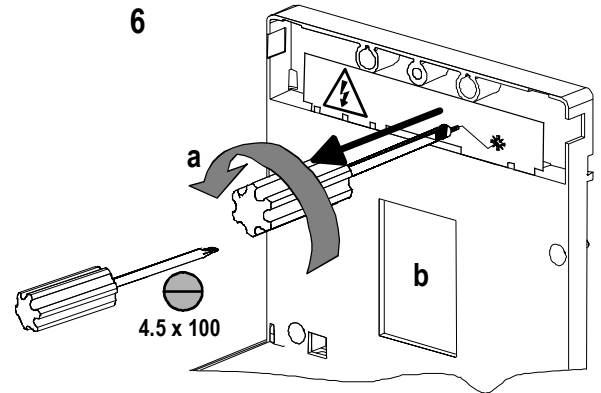
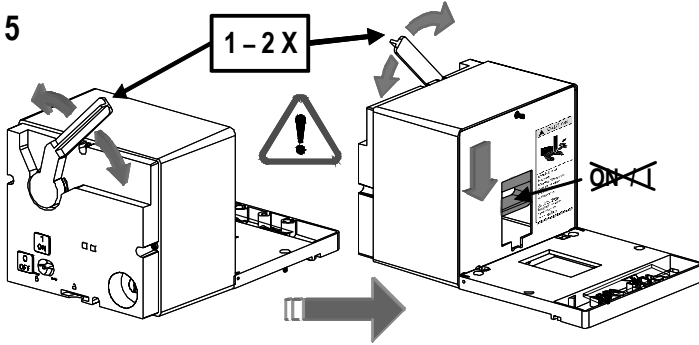
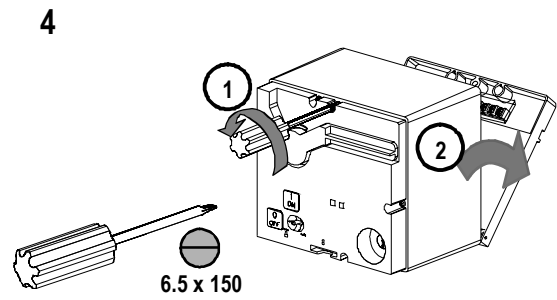
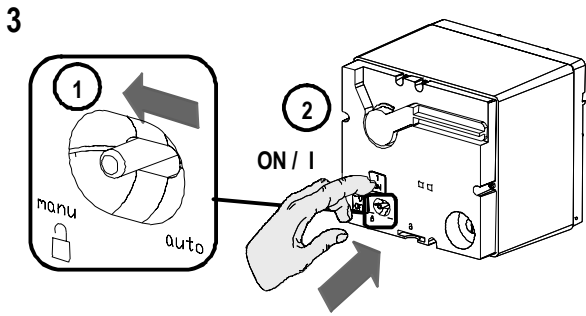

9

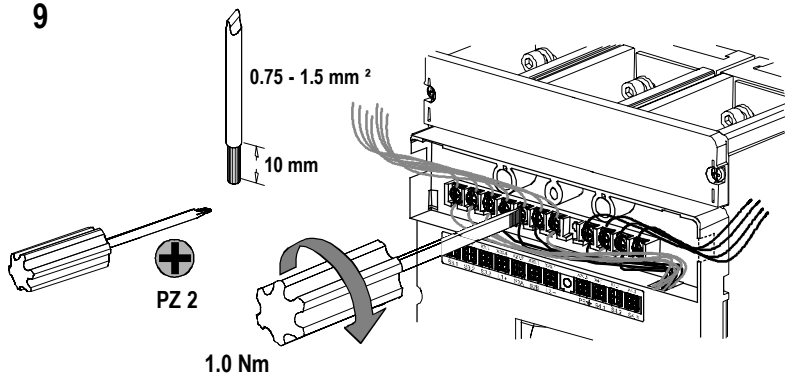

DE	Anschluss links und rechts
EN	Connection left and right
FR	Raccordement à gauche et à droite
ES	Conexión a la izquierda y a la derecha
IT	Attacco a sinistra e destra
PT	Conexão à esquerda e direita
TR	Sol ve sağ bağlantı
PY	Подключение слева и справа
	连接接口在左边和在右边

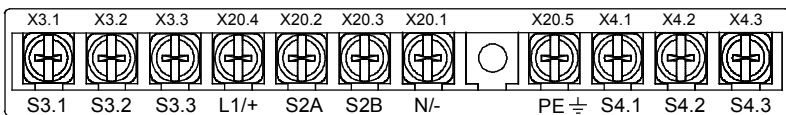

10

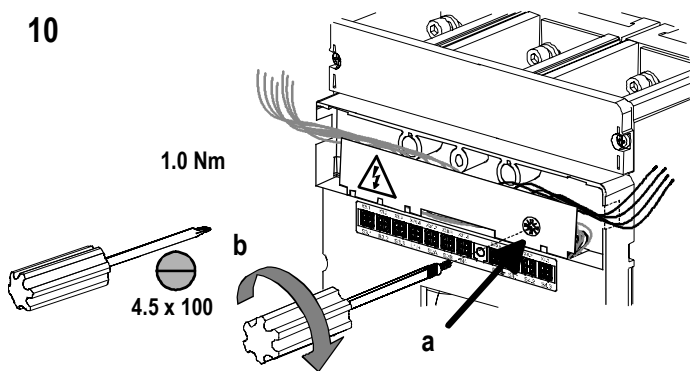

11

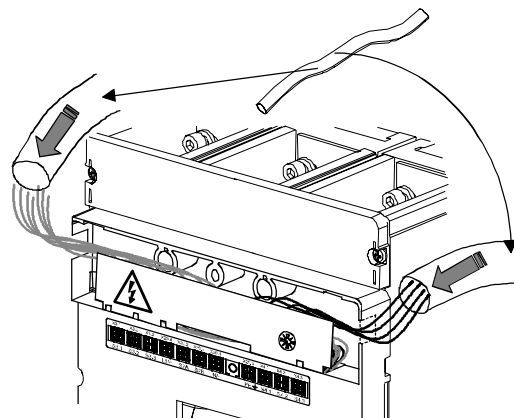

12

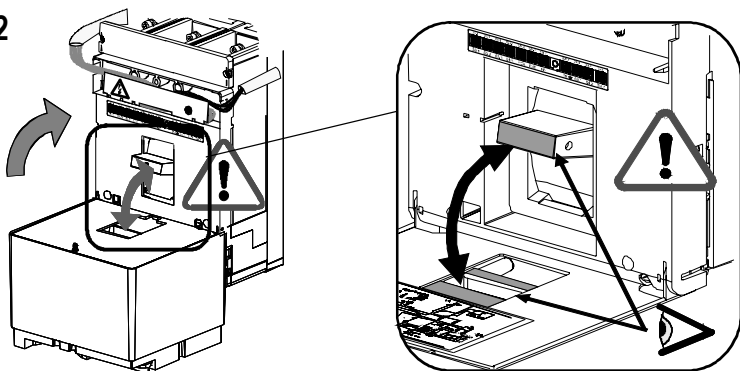

13

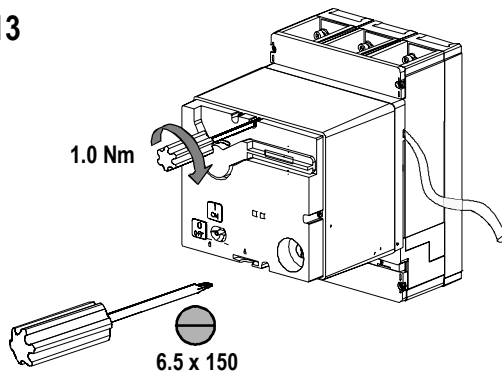

VL400

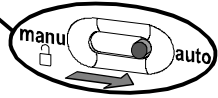
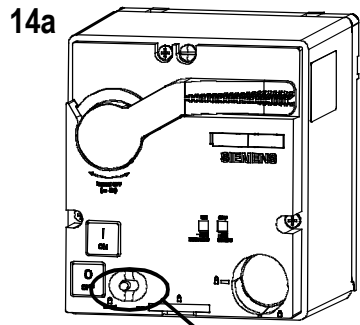

S 3.1 — S 3.2
S 3.3

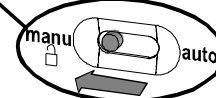
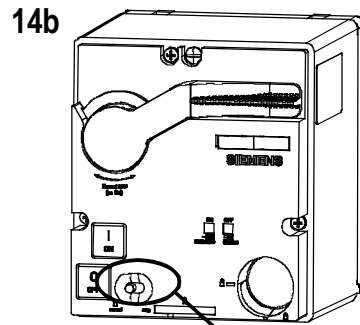

S 3.1 — S 3.2
S 3.3

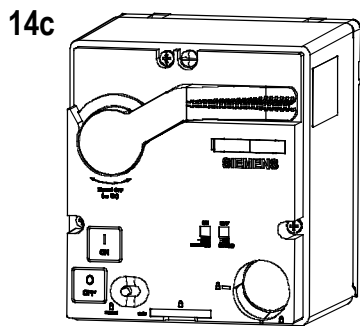

S 4.1 — S 4.2
S 4.3

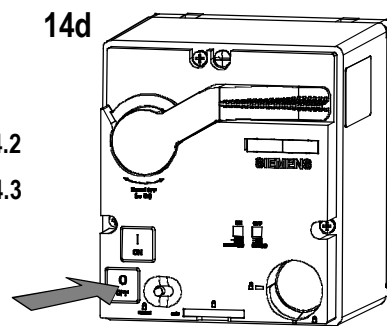

S 4.1 — S 4.2
S 4.3

VL630

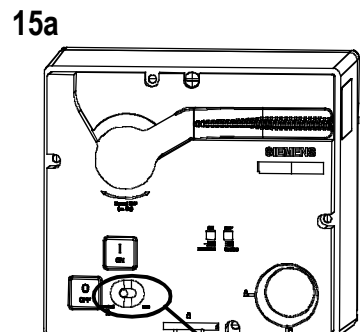

S 3.1 — S 3.2
S 3.3

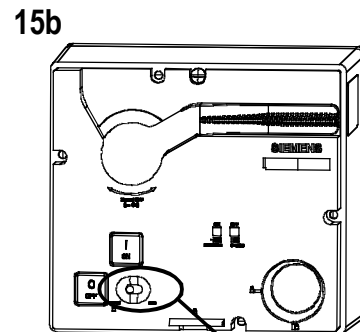

S 3.1 — S 3.2
S 3.3

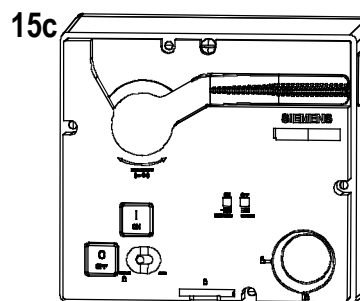

S 4.1 — S 4.2
S 4.3

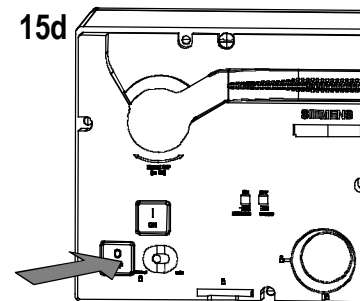

S 4.1 — S 4.2
S 4.3

Deutsch	English	Français	Español	Italiano	Português	Türkçe	Русский	中文
Stecksocket / Einschub mit Zusatzsteck- kontakt	Plug-in socket / Withdrawable unit with additional plug-in contact	Socle d'enfichage / Module débrouvable avec contact à fiche supplémentaire	Zócalo enchufable / Módulo enchufable con contacto de enchufe auxiliar	Connettore base/ Innesto con contatto a spina supplementare	Suporte de encaixe /Inserção com contato de encaixe adicional	Geçme soket / İlave geçme bağlantılı modül	Втычной цоколь / Выдвижной блок с дополнительным втычным контактом	插座 / 带额外插入接 触的插塞

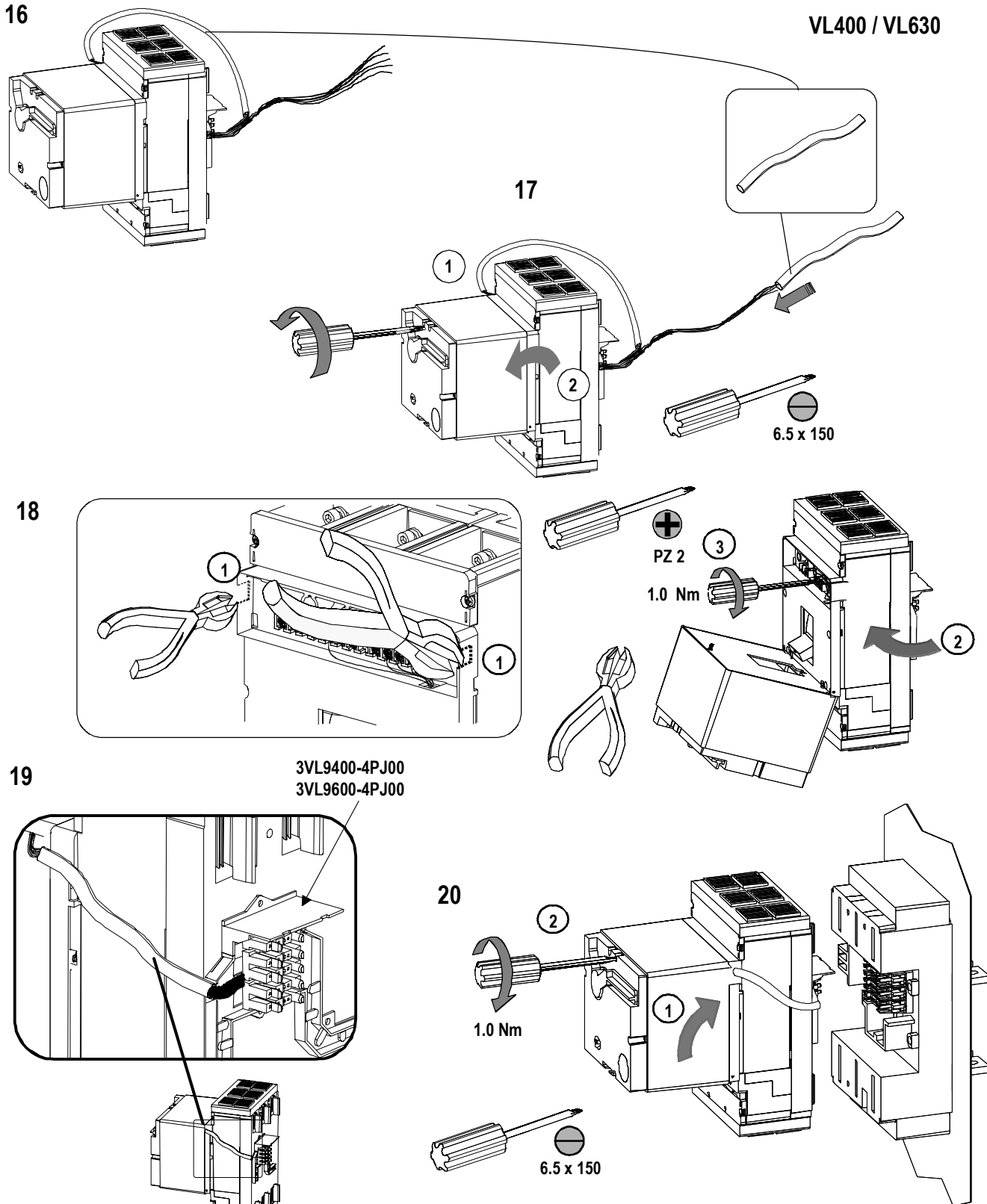

Deutsch	English	Français	Español	Italiano	Português	Türkçe	Русский	中文
Einschub mit Zusatzsteckkontakt	Withdrawable unit with additional plug-in contact	Module débrochable avec contact à fiche supplémentaire	Módulo enchufable con contacto de enchufe auxiliar	Innesto con contatto a spina supplementare	Inserção com contato de encaixe adicional	İlave geçme bağlantılı modül	Выдвижной блок с дополнительным втычным контактом	带额外插入接触的插塞

21

VL800

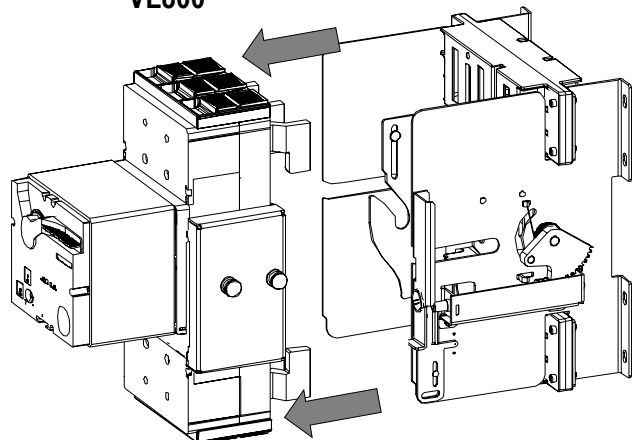

22

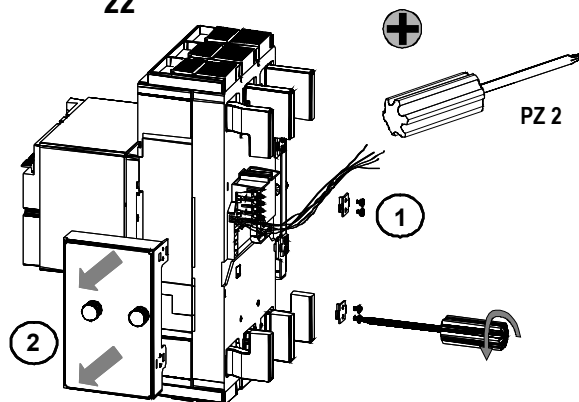

23

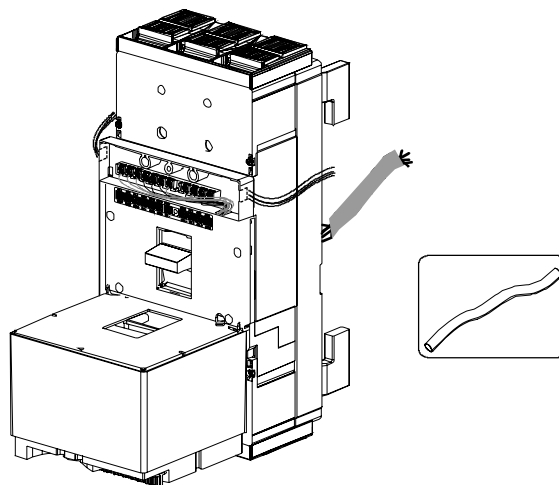
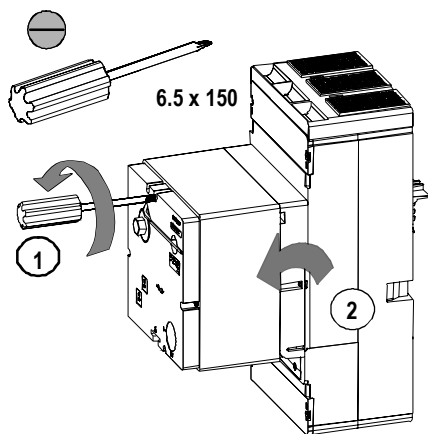

24

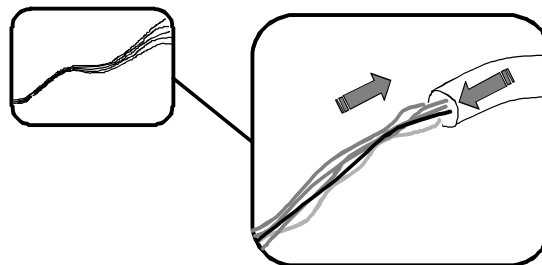

25

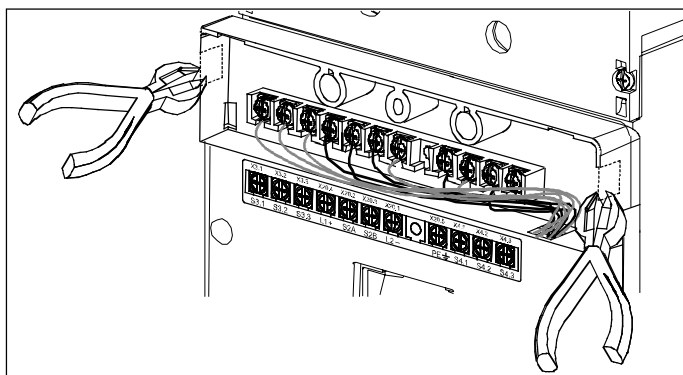

26

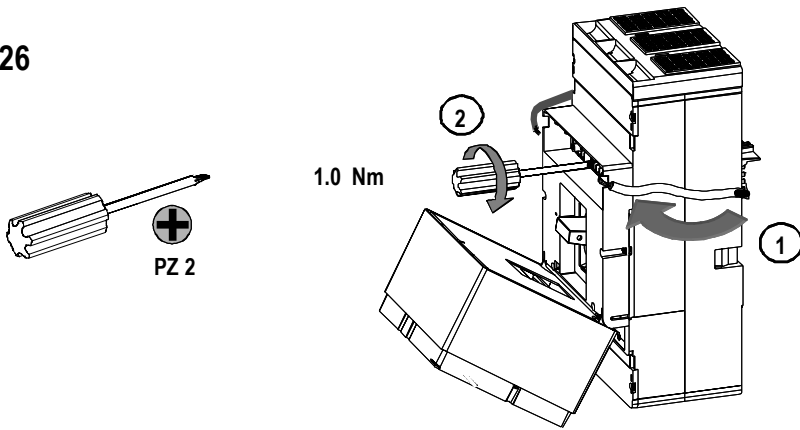

27

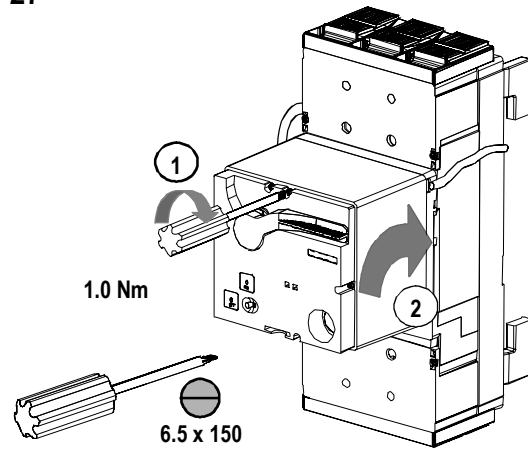

28

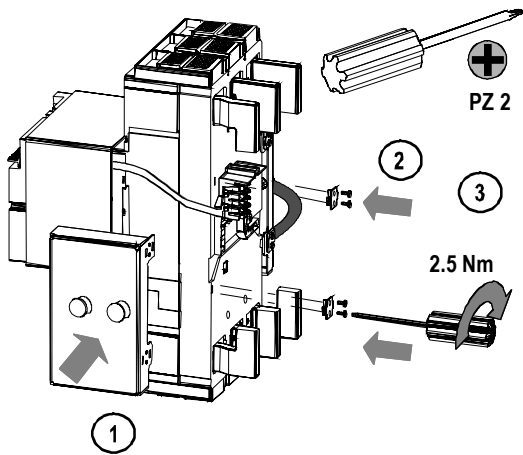

29

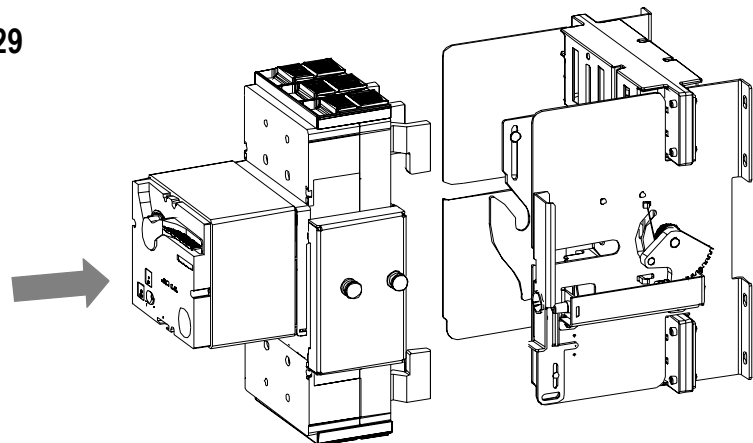

30 TEST- Manual :

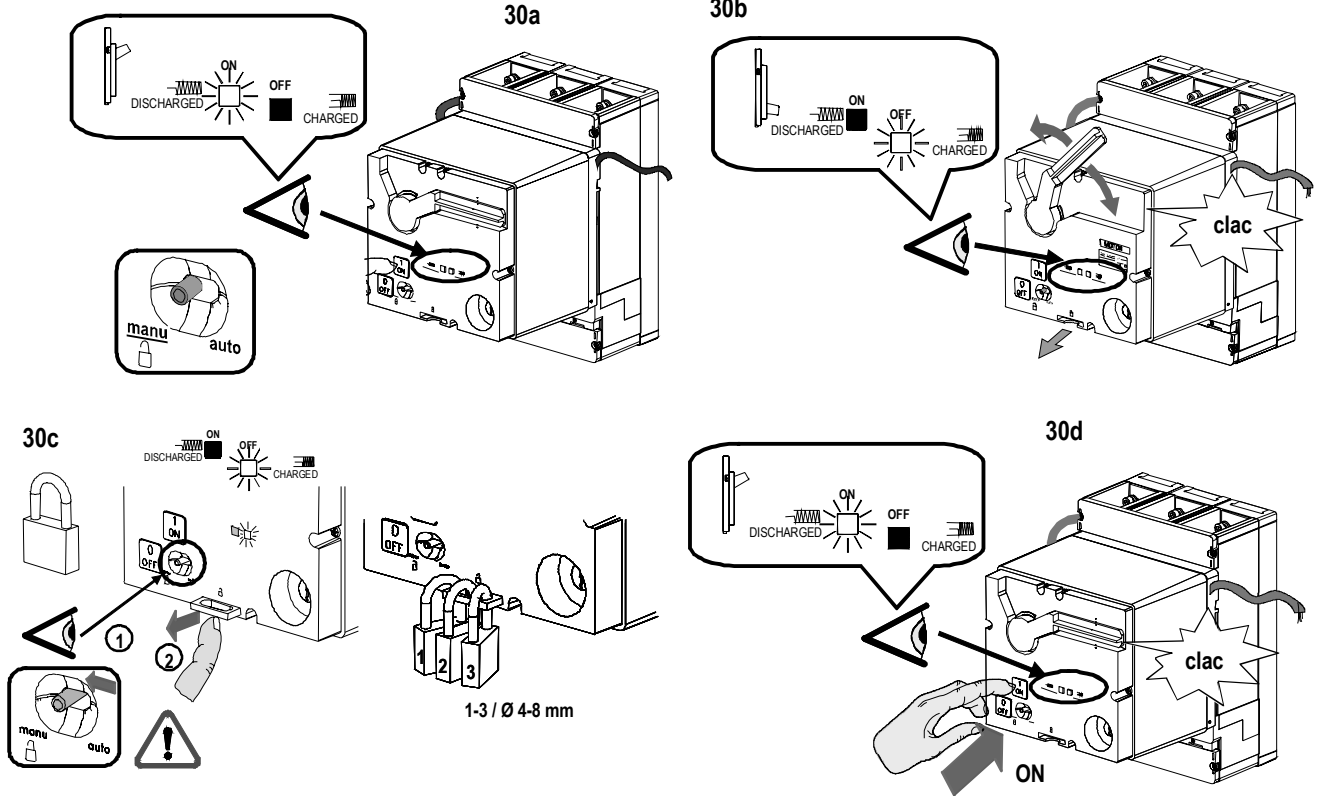

31 TEST - AUTO:

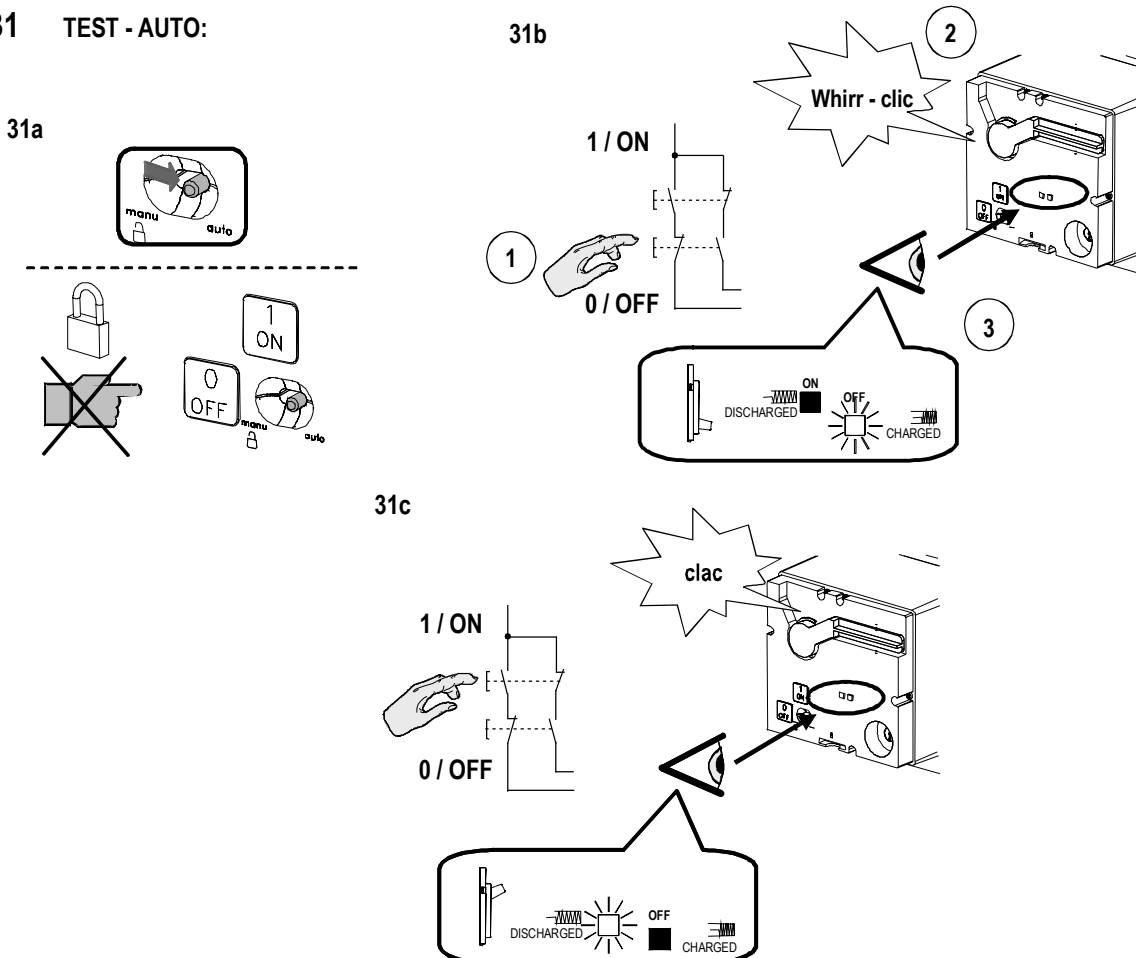

32 Manual TRIP**) - Option*)

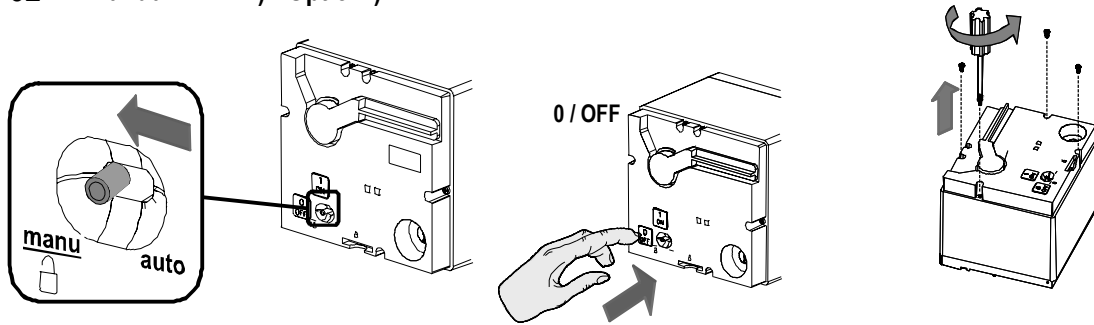

	DE	EN	FR	ES	IT	PT	TR	PY	中文
*)	Option	Option	Option	Opción	Opzione	Opção	Opsiyon	Опция	选项
**)	Auslösen	Trip	Déclencher	Disparar	Sganciare	Disparar	Çözme	Размыкание	脱扣

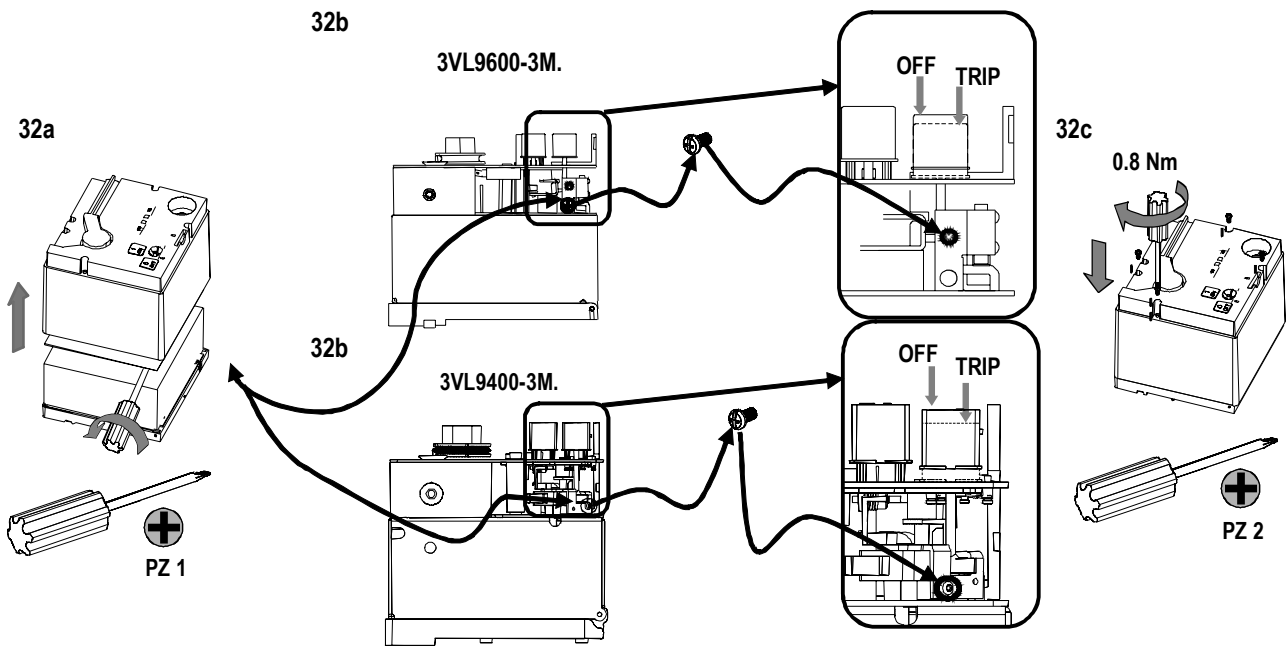

33

3VL9600-3M.00

VL630
VL800

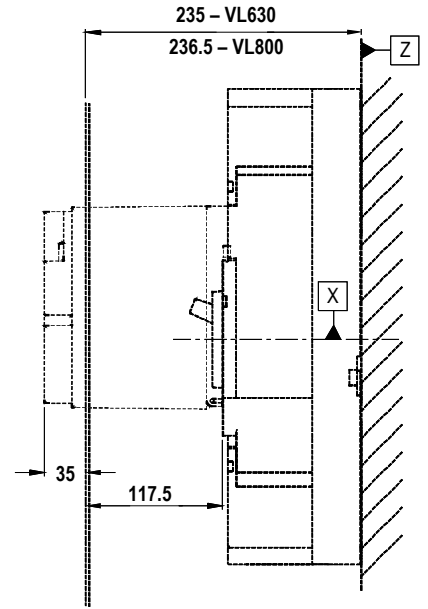
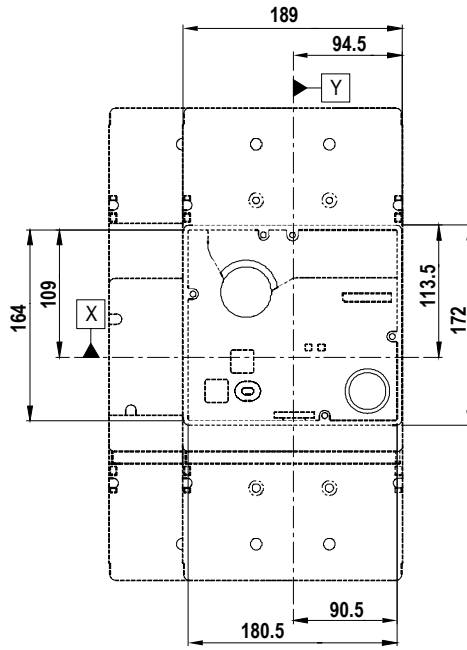
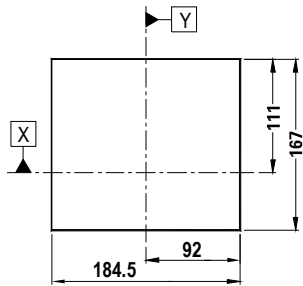

34

3VL9400-3M.00

VL400

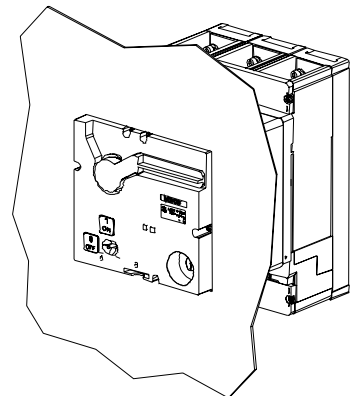
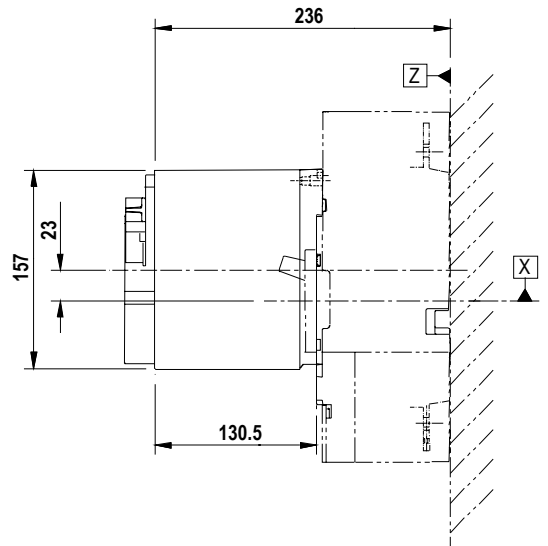
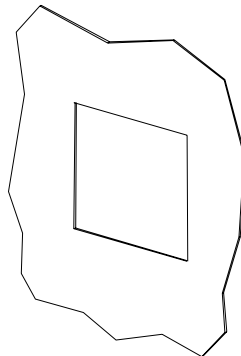
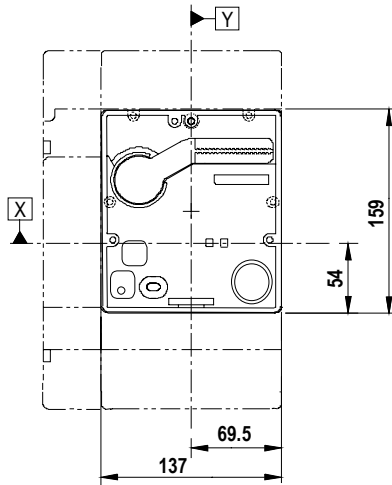
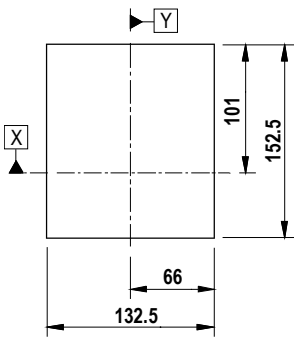

DE	Weitere Informationen finden Sie im 3VL-Handbuch im Internet unter: www.siemens.com/lowvoltage/manuals/3VL (nur in Deutsch und Englisch)
EN	Further information can be found in the 3VL manual on the Internet under www.siemens.com/lowvoltage/manuals/3VL (only in German and English)
FR	Vous trouverez des informations supplémentaires dans le manuel 3VL dans Internet sous www.siemens.com/lowvoltage/manuals/3VL (seulement en allemand et en anglais)
ES	Para más información, consulte el manual 3VL que está disponible en nuestra página web www.siemens.com/lowvoltage/manuals/3VL (solo en alemán y inglés)
IT	Ulteriori informazioni sono disponibili in Internet nel manuale 3VL su www.siemens.com/lowvoltage/manuals/3VL (solo in tedesco e in inglese)
PT	Mais informações encontram-se no manual 3VL na Internet, sob www.siemens.com/lowvoltage/manuals/3VL (somente em alemão e em inglês)
TR	Diğer bilgiler internetde 3VL-el kitabında bulabilirsiniz: www.siemens.com/lowvoltage/manuals/3VL (yanliz almanca ve ingilizce)
РУ	Дальнейшую информацию Вы можете найти в инструкции по использованию 3VL в интернете по адресу: www.siemens.com/lowvoltage/manuals/3VL (только по-немецки или по-английски)
中文	其他相关信息参见 3VL-使用手册, 请登陆互联网: www.siemens.com/lowvoltage/manuals/3VL (英、德文)