

SIEMENS

SENTRON

Motorantrieb

Motorized operating mechanism

Commande motorisée

Mecanismo de accionamiento por motor

Comando a motore

Accionamento do motor

Motor tahriği

Привод двигателя

电动操作机构

3VL9100-3M.10

3VL9300-3M.10

3VL9400-3M.10

3VL9600-3M.10

3VL9800-3M.10

SENTRON® VL



Betriebsanleitung	Operating Instructions	Instructions de service	Instructivo	Istruzioni operative
Instruções de Serviço	İşletme kılavuzu	Руководство по эксплуатации	使用说明	

	Deutsch	English	Français
	Vor der Installation, dem Betrieb oder der Wartung des Geräts muss diese Anleitung gelesen und verstanden werden.	Read and understand these instructions before installing, operating, or maintaining the equipment.	Ne pas installer, utiliser ou intervenir sur cet équipement avant d'avoir lu et assimilé les présentes instructions et notamment les conseils de sécurité et mises en garde qui y figurent.
	⚠ GEFÄHR	⚠ DANGER	⚠ DANGER
	Gefährliche Spannung. Lebensgefahr oder schwere Verletzungsgefahr. Vor Beginn der Arbeiten Anlage und Gerät spannungsfrei schalten.	Hazardous voltage. Will cause death or serious injury. Turn off and lock out all power supplying this device before working on this device.	Tension électrique. Danger de mort ou risque de blessures graves. Mettre hors tension avant d'intervenir sur l'appareil.
	VORSICHT	CAUTION	PRUDENCE
	Eine sichere Gerätefunktion ist nur mit zertifizierten Komponenten gewährleistet.	Reliable functioning of the equipment is only ensured with certified components.	La sécurité de fonctionnement de l'appareil n'est garantie qu'avec des composants certifiés.
	Español	Italiano	Português
	Leer y comprender este instructivo antes de la instalación, operación o mantenimiento del equipo.	Leggere con attenzione queste istruzioni prima di installare, utilizzare o eseguire manutenzione su questa apparecchiatura.	Ler e compreender estas instruções antes da instalação, operação ou manutenção do equipamento.
	⚠ PELIGRO	⚠ PERICOLO	⚠ PERIGO
	Tensión peligrosa. Puede causar la muerte o lesiones graves. Desconectar la alimentación eléctrica antes de trabajar en el equipo.	Tensione pericolosa. Può provocare morte o lesioni gravi. Scollegare l'alimentazione prima di eseguire interventi sull'apparecchiatura.	Tensão perigosa. Perigo de morte ou ferimentos graves. Desligue a alimentação elétrica e proteja contra o religamento, antes de iniciar o trabalho no equipamento.
	PRECAUCIÓN	CAUTELA	CUIDADO
	El funcionamiento seguro del aparato sólo está garantizado con componentes certificados.	Il funzionamento sicuro dell'apparecchiatura è garantito soltanto con componenti certificati.	O funcionamento seguro do aparelho apenas pode ser garantido se forem utilizados os componentes certificados.
	Türkçe	Русский	中文
	Cihazın kurulumundan, çalıştırılmasından veya bakıma tabi tutulmasından önce, bu kılavuzun okunmuş ve anlaşılmiş olması gerekmektedir.	Перед установкой, вводом в эксплуатацию или обслуживанием устройства необходимо прочесть и понять данное руководство.	安装、使用和维修本设备前必须先阅读并理解本说明。
	⚠ TEHLİKE	⚠ ОПАСНО	⚠ 危险
	Tehlikeli gerilim. Ölüm tehlikesi veya ağır yaralanma tehlikesi. Çalışmalara başlamadan önce, sistemin ve cihazın gerilim beslemesini kapatınız.	Опасное напряжение. Опасность для жизни или возможность тяжелых травм. Перед началом работ отключить подачу питания к установке и к устройству.	危险电压。可能导致生命危险或重伤危险。 操作设备时必须确保切断电源。
	ÖNEMLİ DİKKAT	ОСТОРОЖНО	小心
	Cihazın güvenli çalışması ancak sertifikalı bileşenler kullanılması halinde garanti edilebilir.	Безопасность работы устройства гарантируется только при использовании сертифицированных компонентов.	只有使用经过认证的部件才能保证设备的正常运转。

Technical Support:	Internet: http://www.siemens.com/lowvoltage/technical-support
--------------------	---

Einsatzhinweis	Operating note	Remarque d'utilisation	Advertencia sobre el uso	Avvertenza d'uso
Instrução de uso	İlave açıklama	Указание по применению	应用说明	

DE	Achtung	Die Motorantriebe für die Leistungsschalter VL400 (3VL4) bis VL1600 (3VL8) dürfen nur mit den in der nachstehenden Tabelle angegebenen Erzeugnisständen bei den elektronischen Auslöseeinheiten (ETU) und der Kompaktleistungsschalter (MCCB) in Betrieb genommen werden.
EN	Attention	The motorized operating mechanisms for circuit breakers VL400 (3VL4) to VL1600 (3VL8) may only be operated with electronic trip units (ETU) and compact circuit breakers (MCCB) with the product statuses listed in the table below.
FR	Attention	Les commandes motorisées des disjoncteurs VL400 (3VL4) à VL1600 (3VL8) ne peuvent être mises en service qu'avec les versions d'unités de contrôle électronique (ETU) et de disjoncteurs boîtiers moulés (MCCB) indiquées au tableau ci-dessous.
ES	Atención	Los mecanismos de accionamiento por motor para interruptores VL400 (3VL4) a VL1600 (3VL8) solo deben ponerse en marcha con unidades electrónicas de disparo (ETU) e interruptores en caja moldeada (CB) cuyas versiones sean las indicadas en la tabla siguiente.
IT	Attenzione	I comandi a motore per gli interruttori automatici VL400 (3VL4) ... VL1600 (3VL8) possono essere messi in servizio solo con le versioni di prodotto indicate nella tabella sottostante per le unità di sgancio elettroniche (ETU) e gli interruttori automatici scatolati (MCCB).
PT	Atenção	Os acionamentos motorizados dos disjuntores VL400 (3VL4) a VL1600 (3VL8) apenas devem ser colocados em funcionamento com as versões das unidades de ativação (ETU) e disjuntores compactos (MCCB) indicadas na tabela seguinte.
TR	Dikkat	VL400 (3VL4) - VL1600 (3VL8) serisi devre kesicileri için olan motor tahrikleri, sadece aşağıdaki tabloda belirtilen versiyonlara sahip elektronik akım açtırma üniteleri (ETU) ve kompakt devre kesicilerle (MCCB) birlikte işletilebilir.
РУ	Внимание	Приводы двигателей для силовых выключателей от VL400 (3VL4) до VL1600 (3VL8) разрешается вводить в эксплуатацию только с указанными в приведенной ниже таблице версиями электронных расцепителей максимальных токов (ETU) и компактных автоматических выключателей (MCCB).
中文	注意	对于电子脱扣装置 (ETU) 和紧凑型断路器 (MCCB), 只允许通过下列表格中给出的产品状态运行断路器 VL400 (3VL4) 至 VL1600 (3VL8) 的电动操作机构。

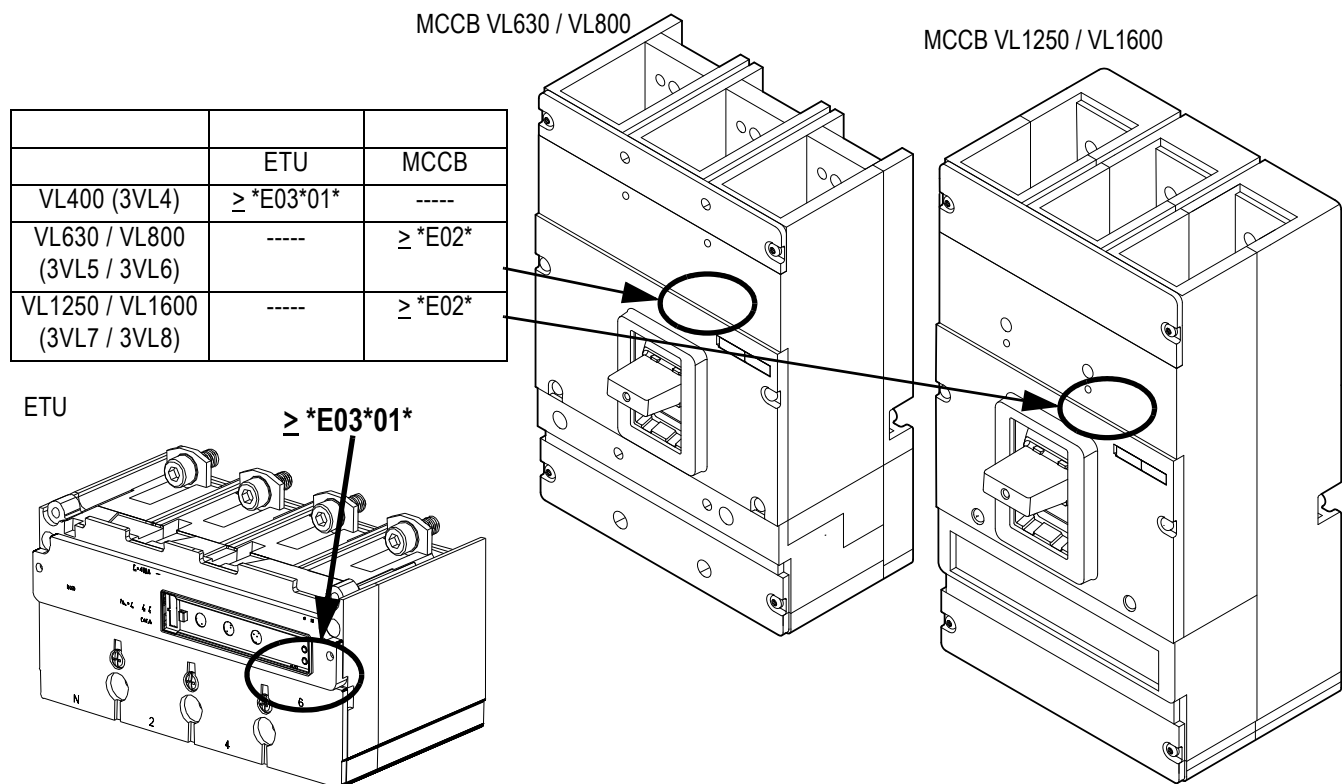

DE	Notwendige Werkzeuge für Montage
EN	Necessary assembly tools
FR	Outils nécessaires pour le montage
ES	Herramientas requeridas para el montaje
IT	Utensili necessari per il montaggio
PT	Ferramentas necessárias para a montagem
TR	Montaj için gerekli aletler
PY	Инструменты, необходимые для монтажа
中文	安装所需工具

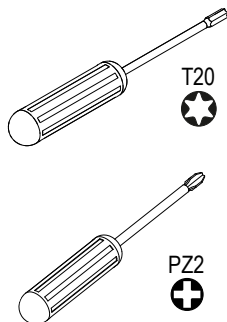

cal. ISO 6789

DE	Optional
EN	Optional
FR	En option
ES	Opcional
IT	Optional
PT	Opcional
TR	Opsiyonal
PY	По выбору
中文	可选择

3VL9000-3MY00

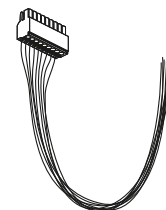

DE	Lieferumfang	EN	Quantity of delivery	FR	Composition de la fourniture
ES	Alcance del suministro	IT	Configurazione di fornitura	PT	Escopo de fornecimento
TR	Teslimat hacmi	PY	Комплект поставки	中文	供货范围

VL160X

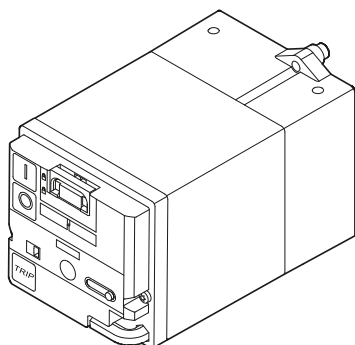

3VL9100-3MA10
3VL9100-3MC10
3VL9100-3MD10
3VL9100-3ME10

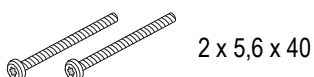

2 x 5,6 x 40

3VL9_00-3MA10	24 VDC
3VL9_00-3MC10	42...60 V AC / DC
3VL9_00-3MD10	110...127 V AC / DC
3VL9_00-3ME10	220...250 V AC / DC

VL160-250

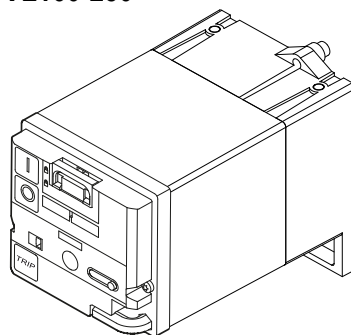

3VL9300-3MA10
3VL9300-3MC10
3VL9300-3MD10
3VL9300-3ME10

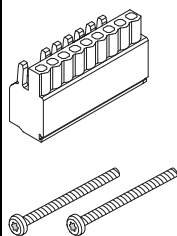

2 x 5,6 x 40

VL400

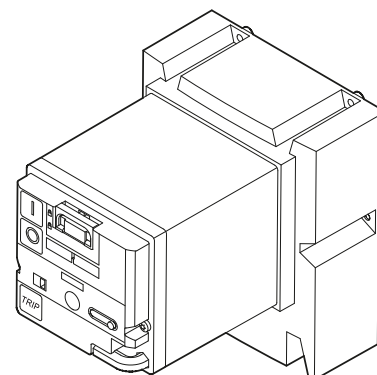

3VL9400-3MA10
3VL9400-3MC10
3VL9400-3MD10
3VL9400-3ME10

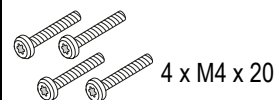
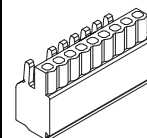

4 x M4 x 20

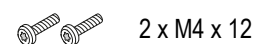

2 x M4 x 12

VL630-800

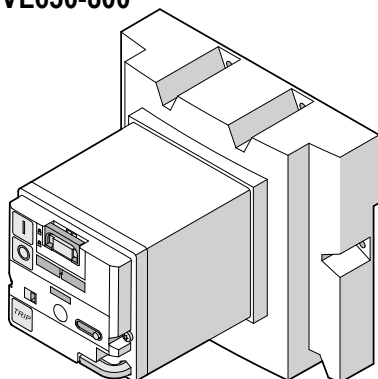

3VL9600-3MA10
3VL9600-3MC10
3VL9600-3MD10
3VL9600-3ME10



2 x M4 x 12

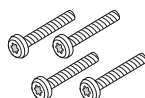
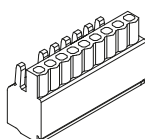

4 x M4 x 20

VL1250-1600

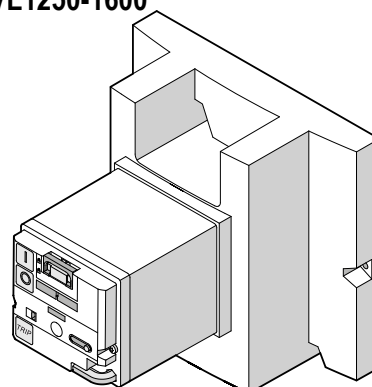

3VL9800-3MA10
3VL9800-3MC10
3VL9800-3MD10
3VL9800-3ME10

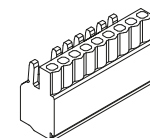

2 x M4 x 12

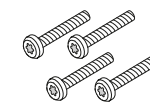

4 x M4 x 20

DE	Montage	EN	Assembly	FR	Montage
ES	Montaje	IT	Montaggio	PT	Montagem
TR	Montaj	PY	Монтаж	中文	安装

1:



Tripped *)

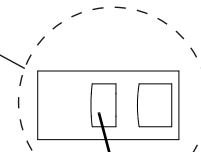
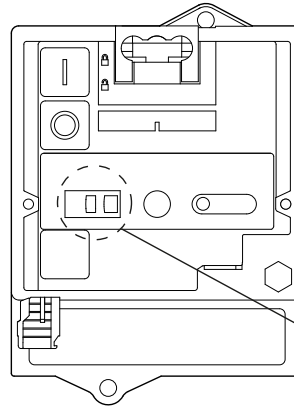
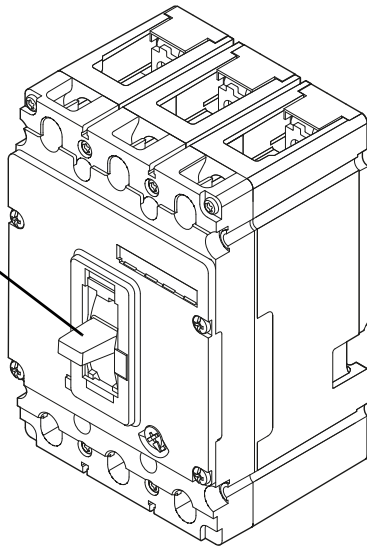

DE	Gelb
EN	Yellow
FR	Jaune
ES	Amarillo
IT	Giallo
PT	Amarelo
TR	Sarı
PY	Желтый
中文	黄色



*)	DE	Ausgelöst
	EN	Tripped
	FR	Déclenché
	ES	Disparado
	IT	Sganciato
	PT	Disparado
	TR	Çözülmüş durum
	PY	Разомкнuto
	中文	断开

VL160X
2.1:

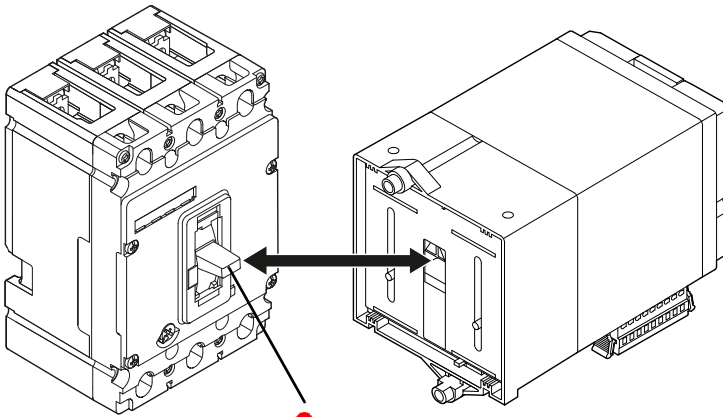

Tripped *)

2.2:

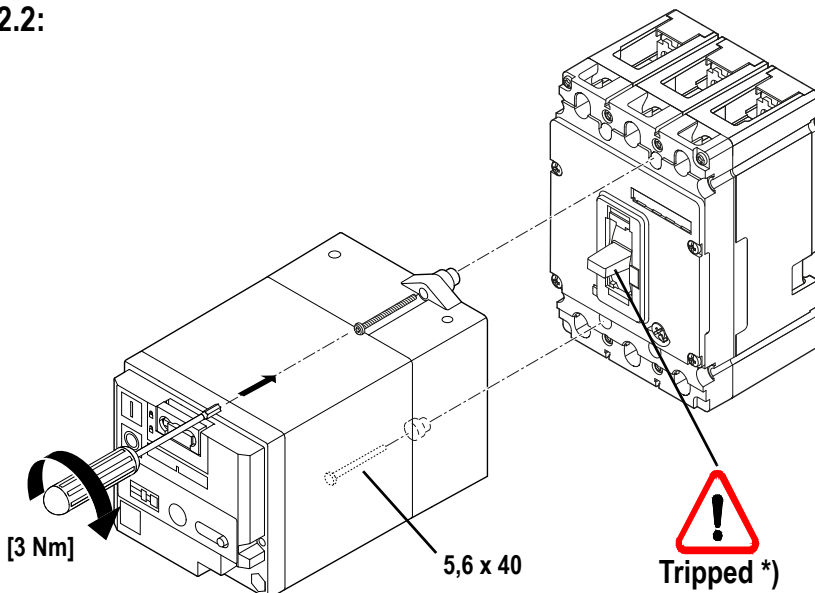

Tripped *)

VL160 - VL250

3.1:

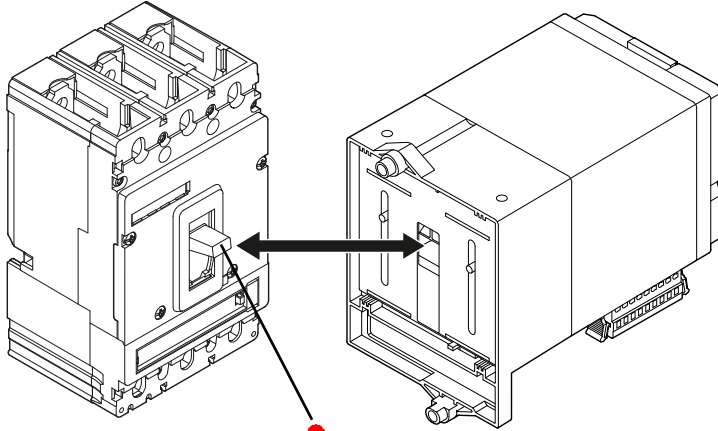

!
 Tripped *)

*)

DE	Ausgelöst
EN	Tripped
FR	Déclenché
ES	Disparado
IT	Sganciato
PT	Disparado
TR	Çözülmüş durum
PY	Разомкнуто
中文	断开

3.2:

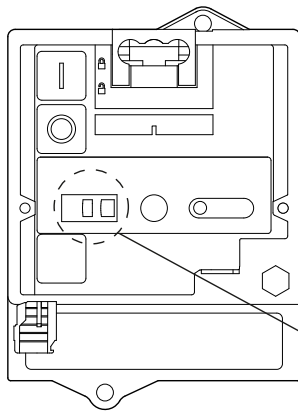

DE	Gelb
EN	Yellow
FR	Jaune
ES	Amarillo
IT	Giallo
PT	Amarelo
TR	Sarı
PY	Желтый
中文	黄色

3.3:

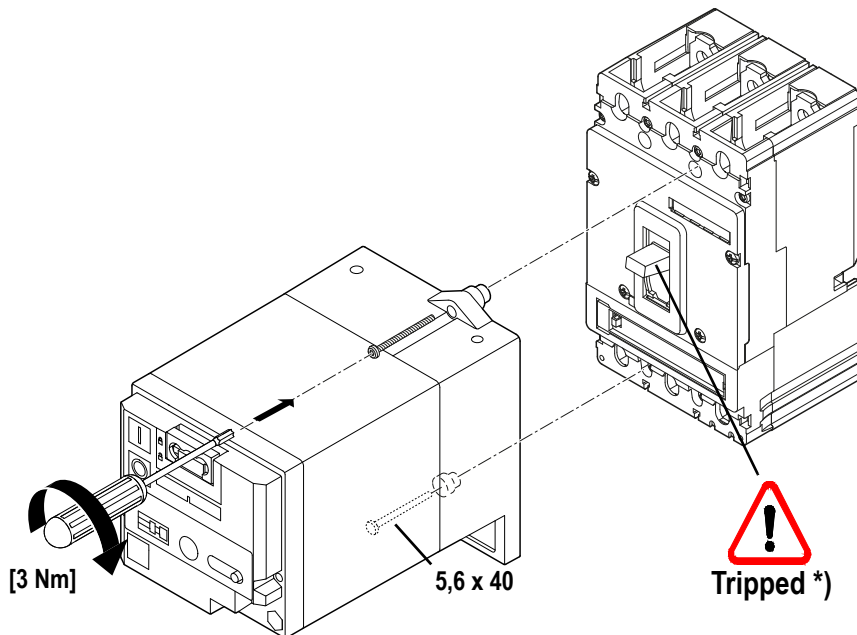

!
 Tripped *)

VL400
4.1:

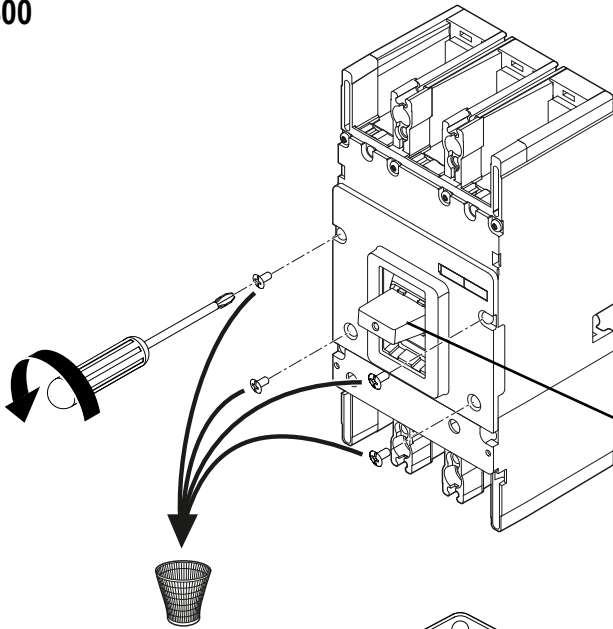

*)

DE	Ausgelöst
EN	Tripped
FR	Déclenché
ES	Disparado
IT	Sganciato
PT	Disparado
TR	Çözülmüş durum
PY	Разомкнуто
中文	断开

4.2:

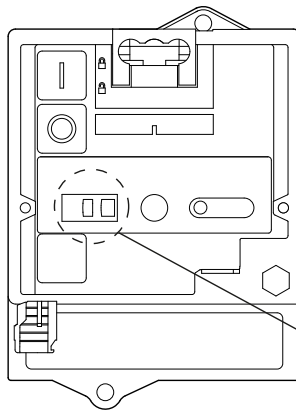

Tripped *)



DE	Gelb
EN	Yellow
FR	Jaune
ES	Amarillo
IT	Giallo
PT	Amarelo
TR	Sarı
PY	Желтый
中文	黄色

4.3:

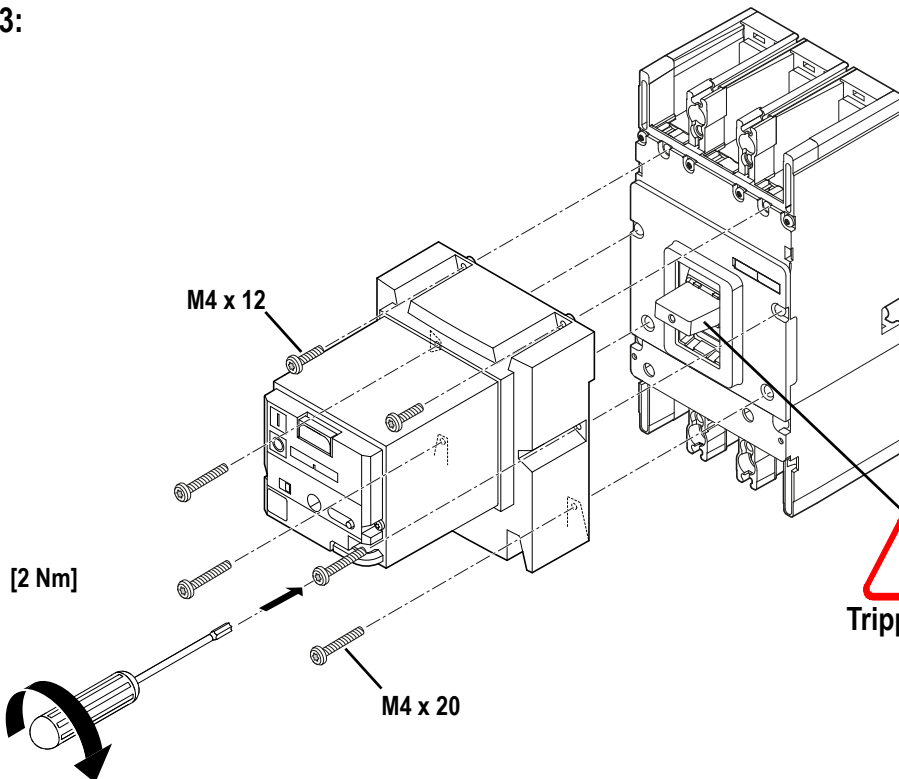

Tripped *)

VL630 / VL800

5.1:

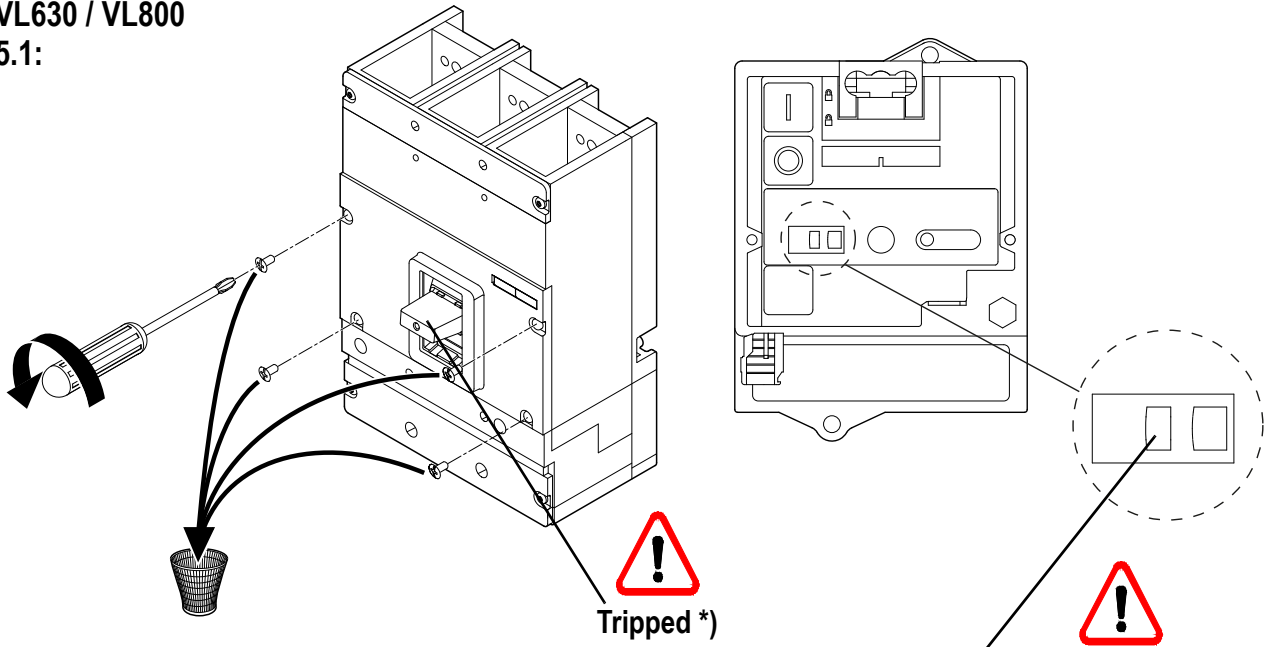

*)

DE	Ausgelöst
EN	Tripped
FR	Déclenché
ES	Disparado
IT	Sganciato
PT	Disparado
TR	Çözülmüş durum
PY	Разомкнуто
中文	断开



DE	Gelb
EN	Yellow
FR	Jaune
ES	Amarillo
IT	Giallo
PT	Amarelo
TR	Sarı
PY	Желтый
中文	黄色

5.2:

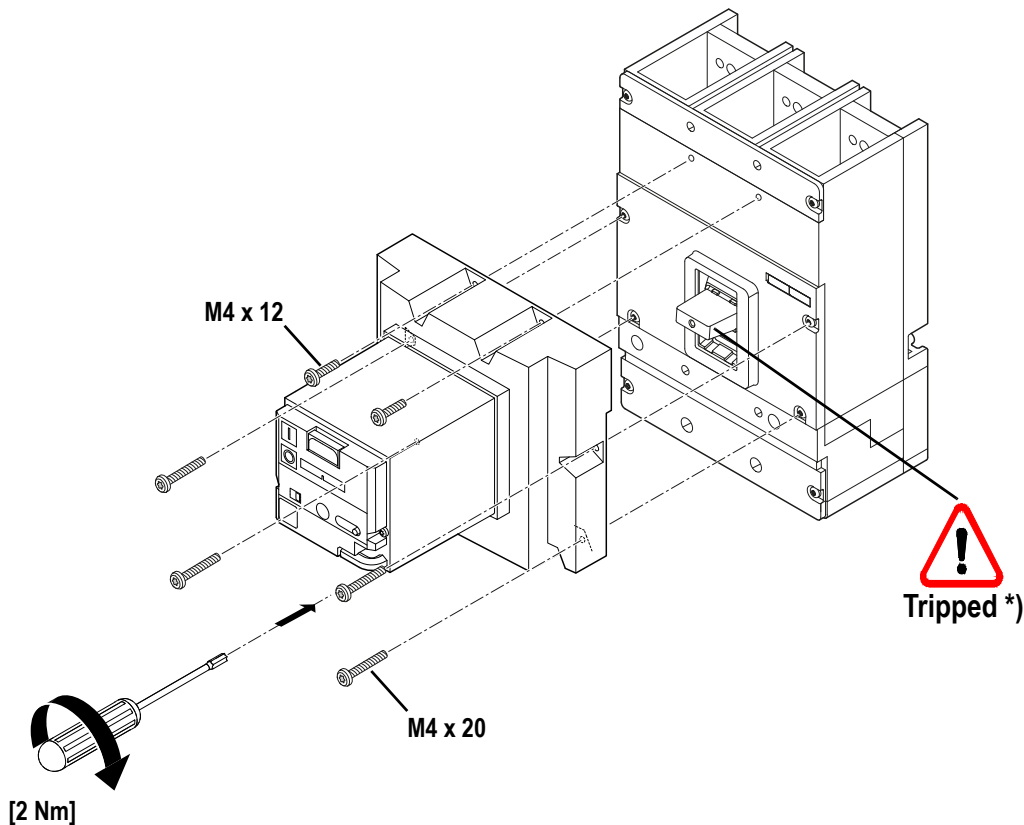

VL1250 / VL1600

6.1:

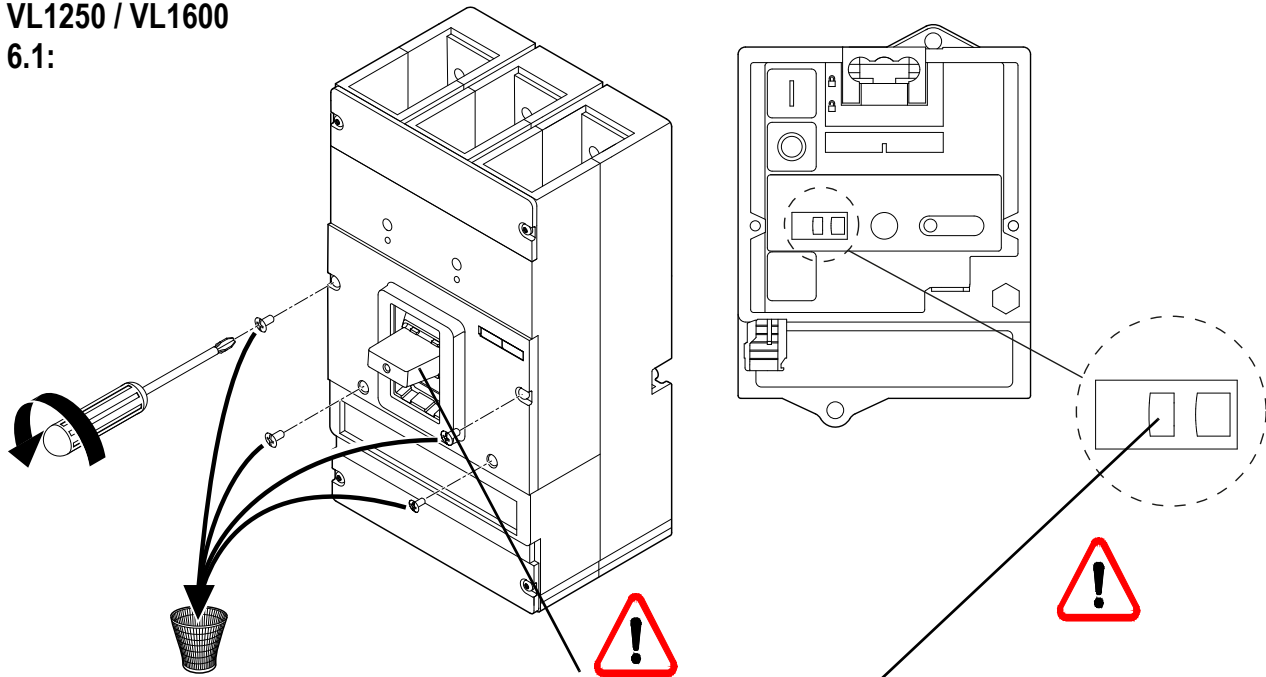

*)

DE	Ausgelöst
EN	Tripped
FR	Déclenché
ES	Disparado
IT	Sganciato
PT	Disparado
TR	Çözülmüş durum
PY	Разомкнуто
中文	断开

Tripped *)



DE	Gelb
EN	Yellow
FR	Jaune
ES	Amarillo
IT	Giallo
PT	Amarelo
TR	Sarı
PY	Желтый
中文	黄色

6.2:

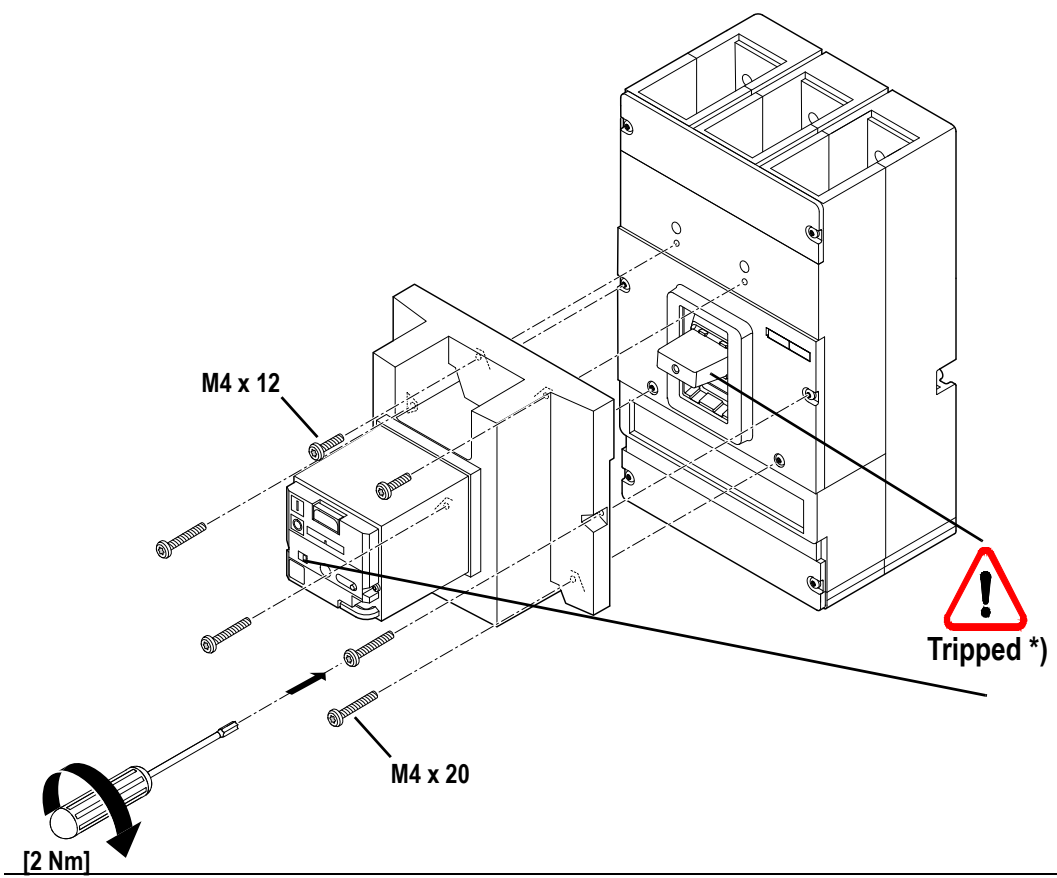

Tripped *)

9	X10.9	PE	16 A / 250 V AC; 0,4 A / 125 V DC; 0,2 A / 250 V DC
8	X10.8	S3	
7	X10.7	S3	
6	X10.6	S3	
5	X10.5	S2A "OFF"	24 V DC / 42...60 V AC / DC / 110...127 V AC / DC / 220...250 V AC / DC
4	X10.4	S2B "ON"	
3	X10.3	L1 (L+) [X10.1]	
2	X10.2	N (L-)	
1	X10.1	L1 (L+)	

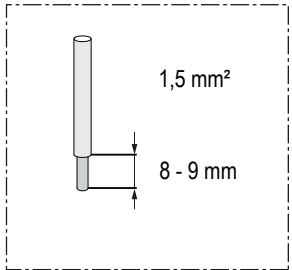

VL160X - VL250

7a

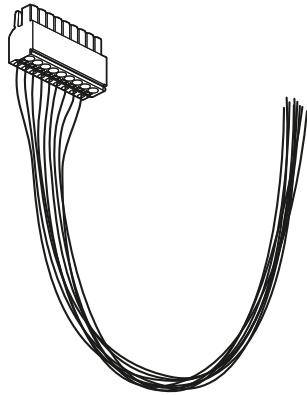

7b

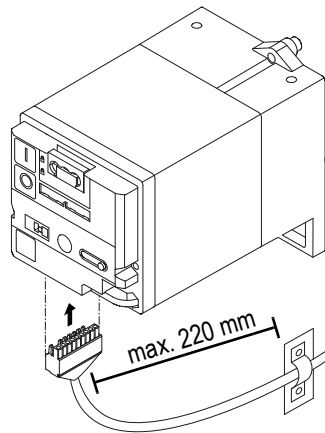

VL400 - VL800

8a

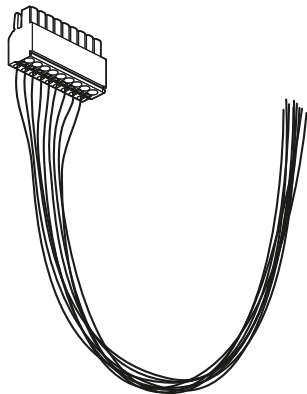

8b

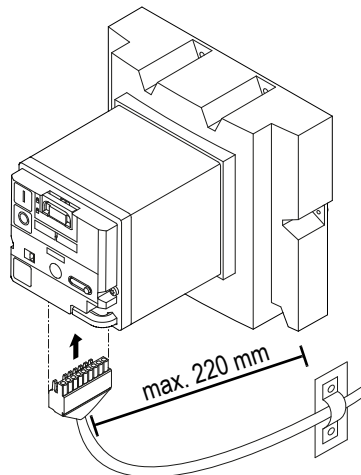

VL1250 - VL1600

9a

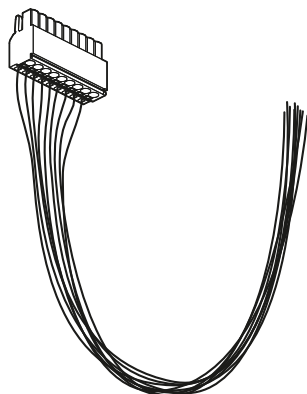

9b

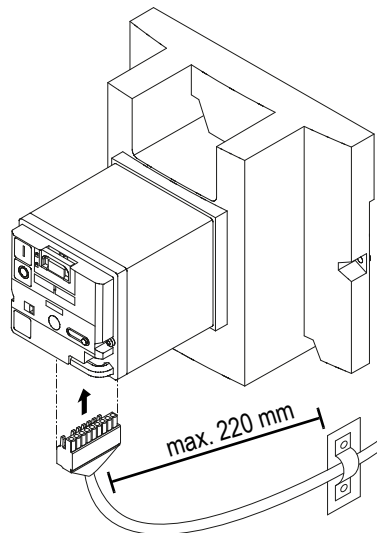

DE	Test Manuell	EN	Test Manual	FR	Test manuel
ES	Test manual	IT	Test manuale	PT	Teste manual
TR	Test Manüel	PY	Проверка вручную	中文	测试手动

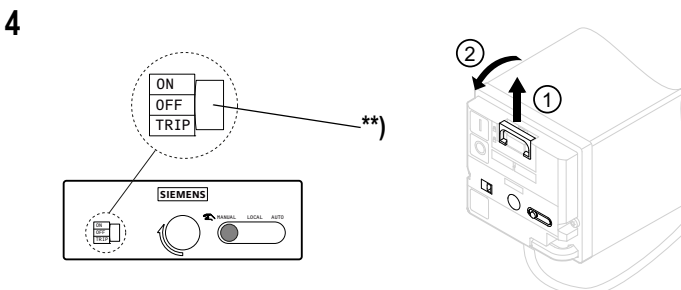
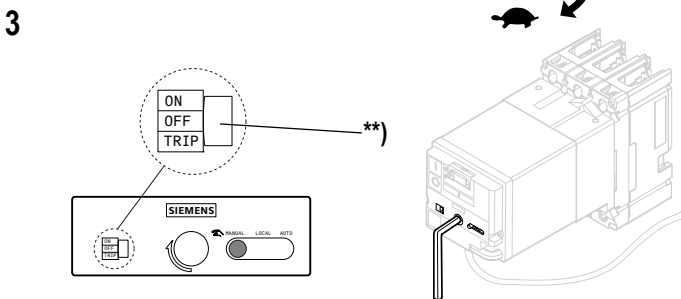
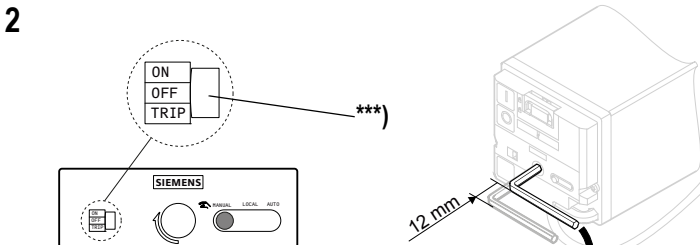
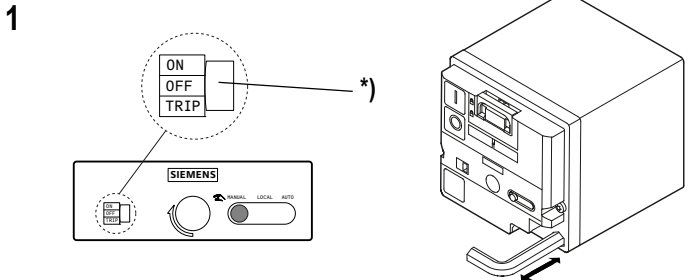
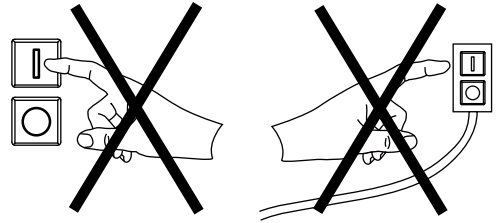
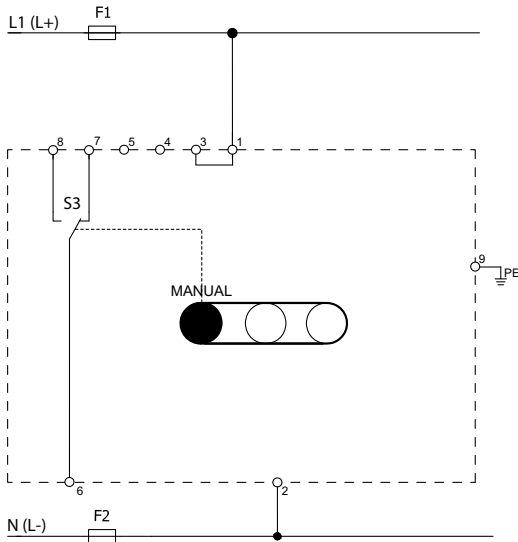

	*)	**)	***)
DE	Grün= An	Rot= Aus	Gelb= Trip
EN	Green= On	Red= Off	Yellow= Trip
FR	Vert= Marche	Rouge= Arrêt	Jaune= Déclenchement
ES	Verde= Con	Rojo= Des	Amarillo= Disp.
IT	Verde= On	Rosso= Off	Giallo= Scatto
PT	Verde= Ligado	Vermelho= Desligado	Amarelo= Disparo
TR	Yeşil= Açık	Kırmızı= Kapalı	Sarı= Trip
PY	Зеленый= Вкл.	Красный= Выкл.	Желтый= Авар.откл.
中文	绿色 = 接通	红色 = 断路	黄色 = 脱扣

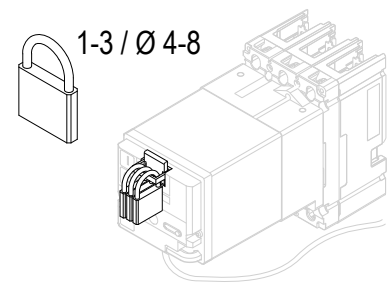
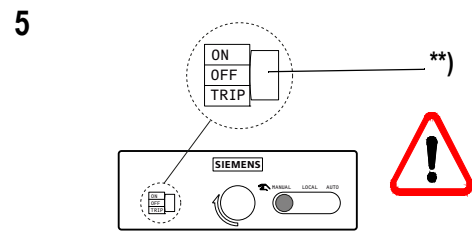

DE	Test Local	EN	Test Local	FR	Test local
ES	Test local	IT	Test locale	PT	Teste local
TR	Test Lokal	PY	Локальная проверка	中文	局部测试

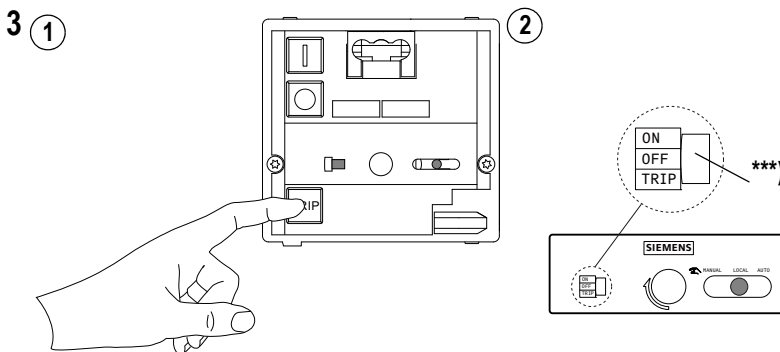
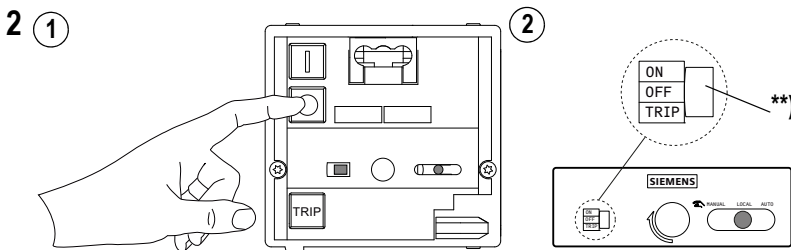
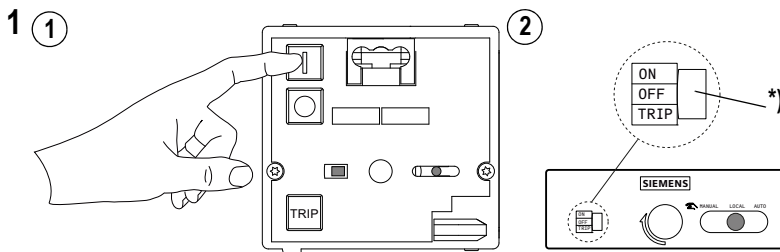
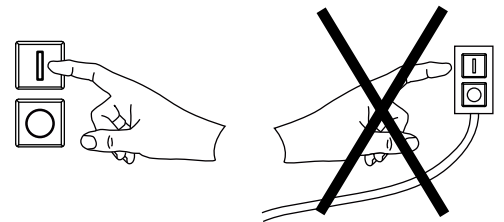
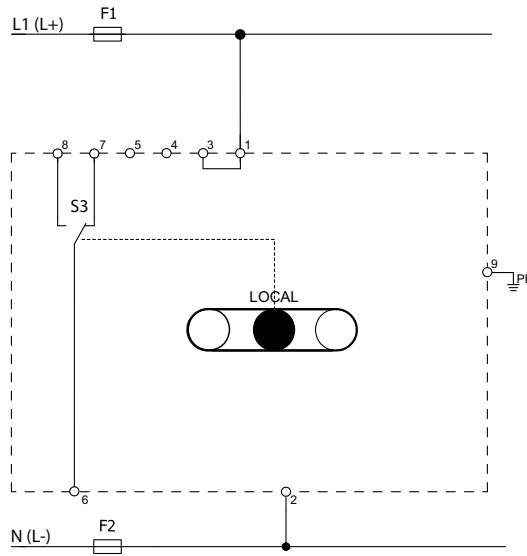

	*)	**)	***)
DE	Grün= An	Rot= Aus	Gelb= Trip
EN	Green= On	Red= Off	Yellow= Trip
FR	Vert= Marche	Rouge= Arrêt	Jaune= Déclenchement
ES	Verde= Con	Rojo= Des	Amarillo= Disp.
IT	Verde= On	Rosso= Off	Giallo= Scatto
PT	Verde= Ligado	Vermelho= Desligado	Amarelo= Disparo
TR	Yeşil= Açık	Kırmızı= Kapalı	Sarı= Trip
PY	Зеленый= Вкл.	Красный= Выкл.	Желтый= Авар.откл.
中文	绿色 = 接通	红色 = 断路	黄色 = 脱扣

DE	Test Auto	EN	Test Auto	FR	Test automatique
ES	Test automático	IT	Test autom.	PT	Teste automático
TR	Test Otomatik	PY	Атомат. проверка	中文	自动测试

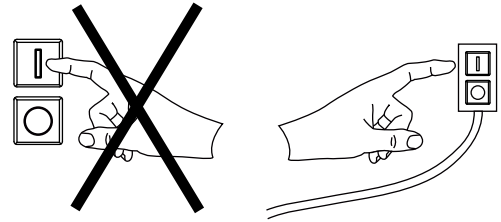
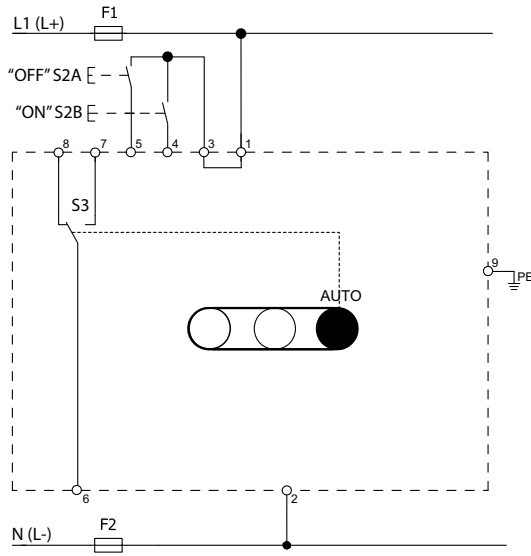

1 ①

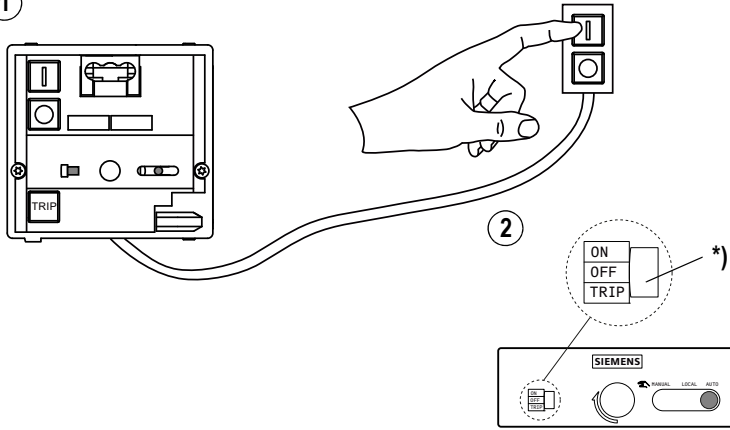

	*)	**)	***)
DE	Grün= An	Rot= Aus	Gelb= Trip
EN	Green= On	Red= Off	Yellow= Trip
FR	Vert= Marche	Rouge= Arrêt	Jaune= Déclenchement
ES	Verde= Con	Rojo= Des	Amarillo= Disp.
IT	Verde= On	Rosso= Off	Giallo= Scatto
PT	Verde= Ligado	Vermelho= Desligado	Amarelo= Disparo
TR	Yeşil= Açık	Kırmızı= Kapalı	Sarı= Trip
PY	Зеленый= Вкл.	Красный= Выкл.	Желтый= Авар.откл.
中文	绿色 = 接通	红色 = 断路	黄色 = 脱扣

2 ①

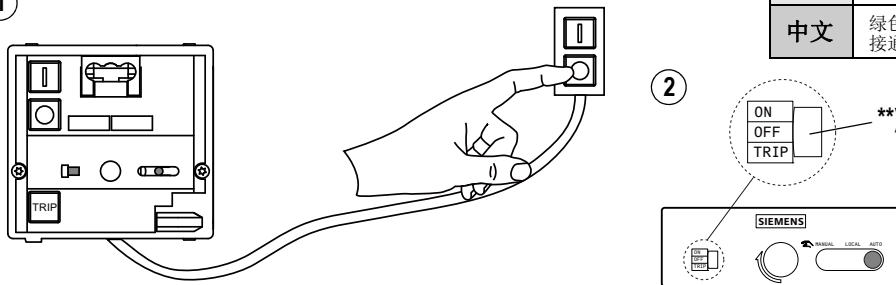

3 ①

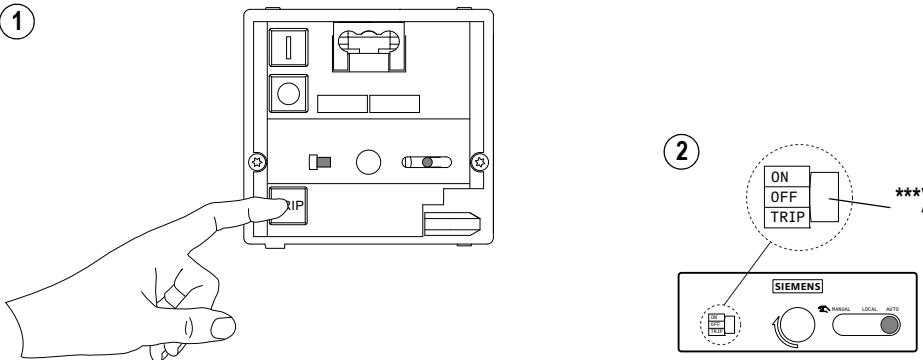

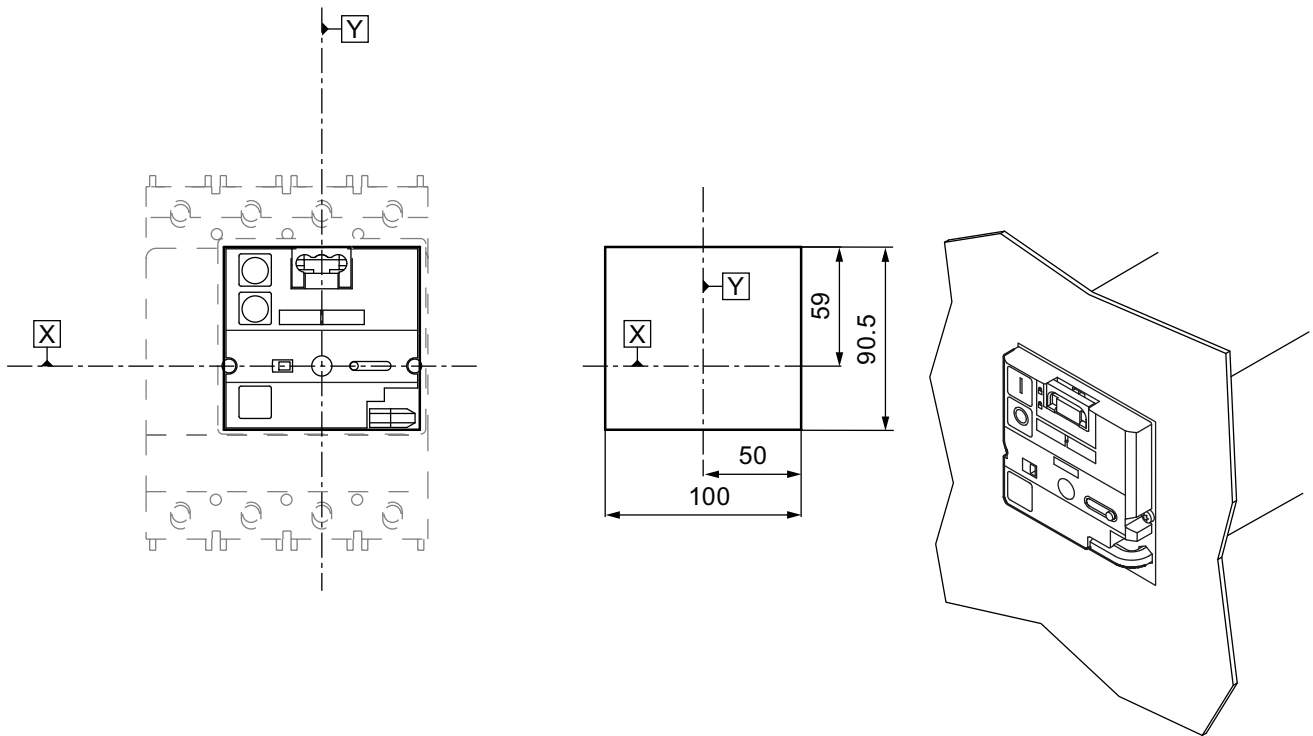

DE	Weitere Informationen finden Sie im 3VL-Handbuch im Internet unter: www.siemens.com/lowvoltage/manuals (nur in Deutsch und Englisch)
EN	Further information can be found in the 3VL manual on the Internet under www.siemens.com/lowvoltage/manuals (only in German and English)
FR	Vous trouverez des informations supplémentaires dans le manuel 3VL dans Internet sous www.siemens.com/lowvoltage/manuals (seulement en allemand et en anglais)
ES	Para más información, consulte el manual 3VL que está disponible en nuestra página web www.siemens.com/lowvoltage/manuals (solo en alemán y inglés)
IT	Ulteriori informazioni sono disponibili in Internet nel manuale 3VL su www.siemens.com/lowvoltage/manuals (solo in tedesco e in inglese)
PT	Mais informações encontram-se no manual 3VL na Internet, sob www.siemens.com/lowvoltage/manuals (somente em alemão e em inglês)
TR	Diğer bilgileri internetde 3VL-el kitabında bulabilirsiniz: www.siemens.com/lowvoltage/manuals (yanlız almanca ve ingilizce)
PY	Дальнейшую информацию Вы можете найти в инструкции по использованию 3VL в интернете по адресу: www.siemens.com/lowvoltage/manuals (только по-немецки или по-английски)
中文	其他相关信息参见 3VL- 使用手册, 请登陆互联网: www.siemens.com/lowvoltage/manuals (英、德文)