

Circuit Breaker,

Frame JG, LG

Interruptor, Caja Base JG, LG

Disjoncteur,

de Base JG, LG

For use with Frame JG, LG

Para usar con caja Base JG, LG

U.S. Cat. No.

.J.2B...
.J.3B...
.J.3R...
.J.3W...
.J.3T...
.J.3V...
.J.3A...
.J.3K...
.J.3G...
.JS.S400

.L.2B...
.L.3B...
.L.3R...
.L.3W...
.L.3T...
.L.3V...
.L.3A...
.L.3K...
.L.3G...
.LR.S600

Order No.

3VL41...-KN30-...
3VL41...-PB30-...
3VL41...-PD30-...
3VL41...-PE30-...
3VL41...-PH30-...
3VL41...-VH30-...
3VL41...-VJ30-...
3VL41...-VM30-...
3VL4140-KE-...-...

3VL48...-KN30-...
3VL48...-PB30-...
3VL48...-PD30-...
3VL48...-PE30-...
3VL48...-PH30-...
3VL48...-VH30-...
3VL48...-VJ30-...
3VL48...-VM30-...
3VL43...-KN30-...
3VL4860-KE-...-...

Betriebsanleitung

Instruções de Serviço

Operating Instructions

İşletme kılavuzu



Instructions de service

Инструкция по эксплуатации

Instructivo

使用说明

Istruzioni operative

	Deutsch	English	Français
	Vor der Installation, dem Betrieb oder der Wartung des Geräts muss diese Anleitung gelesen und verstanden werden.	Read and understand these instructions before installing, operating, or maintaining the equipment.	Ne pas installer, utiliser ou intervenir sur cet équipement avant d'avoir lu et assimilé les présentes instructions et notamment les conseils de sécurité et mises en garde qui y figurent.
	⚠ GEFAHR	⚠ DANGER	⚠ DANGER
	Gefährliche Spannung. Lebensgefahr oder schwere Verletzungsgefahr. Vor Beginn der Arbeiten Anlage und Gerät spannungsfrei schalten.	Hazardous voltage. Will cause death or serious injury. Turn off and lock out all power supplying this device before working on this device.	Tension électrique. Danger de mort ou risque de blessures graves. Mettre hors tension avant d'intervenir sur l'appareil.
	VORSICHT	CAUTION	PRUDENCE
	Eine sichere Gerätefunktion ist nur mit zertifizierten Komponenten gewährleistet.	Reliable functioning of the equipment is only ensured with certified components.	La sécurité de fonctionnement de l'appareil n'est garantie qu'avec des composants certifiés.
	Español	Italiano	Português
	Leer y comprender este instructivo antes de la instalación, operación o mantenimiento del equipo.	Leggere con attenzione queste istruzioni prima di installare, utilizzare o eseguire manutenzione su questa apparecchiatura.	Ler e compreender estas instruções antes da instalação, operação ou manutenção do equipamento.
	⚠ PELIGRO	⚠ PERICOLO	⚠ PERIGO
	Tensión peligrosa. Puede causar la muerte o lesiones graves. Desconectar la alimentación eléctrica antes de trabajar en el equipo.	Tensione pericolosa. Può provocare morte o lesioni gravi. Scollegare l'alimentazione prima di eseguire interventi sull'apparecchiatura.	Tensão perigosa. Perigo de morte ou ferimentos graves. Desligue a alimentação elétrica e proteja contra o religamento, antes de iniciar o trabalho no equipamento.
	PRECAUCIÓN	CAUTELA	CUIDADO
	El funcionamiento seguro del aparato sólo está garantizado con componentes certificados.	Il funzionamento sicuro dell'apparecchiatura è garantito soltanto con componenti certificati.	O funcionamento seguro do aparelho apenas pode ser garantido se forem utilizados os componentes certificados.
	Türkçe	Русский	中文
	Cihazın kurulumundan, çalıştırılmasından veya bakıma tabi tutulmasından önce, bu kılavuzun okunmuş ve anlaşılmış olması gerekmektedir.	Перед установкой, вводом в эксплуатацию или обслуживанием устройства необходимо прочесть и понять данное руководство.	安装、使用和维修本设备前必须先阅读并理解本说明。
	⚠ TEHLİKE	⚠ ОПАСНО	⚠ 危险
	Tehlikeli gerilim. Ölüm tehlikesi veya ağır yaralanma tehlikesi. Çalışmalara başlamadan önce, sistemin ve cihazın gerilim beslemesini kapatınız.	Опасное напряжение. Опасность для жизни или возможность тяжелых травм. Перед началом работ отключить подачу питания к установке и к устройству.	危险电压。可能导致生命危险或重伤危险。 操作设备时必须确保切断电源。
	ÖNEMLİ DİKKAT	ОСТОРОЖНО	小心
	Cihazın güvenli çalışması ancak sertifikalı bileşenler kullanılması halinde garanti edilebilir.	Безопасность работы устройства гарантируется только при использовании сертифицированных компонентов.	只有使用经过认证的部件才能保证设备的正常运转。

Technical Support:

Internet: <http://www.siemens.com/lowvoltage/technical-support>

NOTE

These instructions do not purport to cover all details or variations in equipment, or to provide for every possible contingency to be met in connection with installation, operation or maintenance. Should further information be desired or should particular problems arise, which are not covered sufficiently for the purchaser's purposes, the matter should be referred to the local Siemens sales office. The contents of this Instruction manual shall not become part of or modify any prior or existing agreement, commitment or relationship. The sales contract contains the entire obligation of Siemens. The warranty contained in the contract between the parties is the sole warranty of Siemens. Any statements contained herein do not create new warranties or modify the existing warranty.

Trademarks - Unless otherwise noted, all names identified by ® are registered trademarks of Siemens AG or Siemens Industry, Inc. The remaining trademarks in this publication may be trademarks whose use by third parties for their own purposes could violate the rights of the owner.



Use only with Siemens certified Components.

Utilizar únicamente con componentes certificados de Siemens.

A utiliser uniquement avec les composants certifiés Siemens.

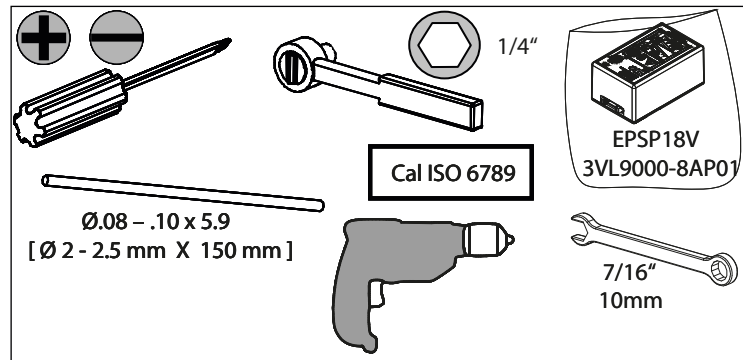
DE	Notwendige Werkzeuge für Montage
EN	Necessary assembly tools
FR	Outils nécessaires pour le montage
ES	Herramientas requeridas para el montaje
IT	Utensili necessari per il montaggio
PT	Ferramentas necessárias para a montagem
TR	Montaj için gerekli aletler
PY	Инструменты, необходимые для монтажа
中文	安装所需工具



⚠ DANGER	⚠ PELIGRO	⚠ DANGER
 Hazardous voltage. Will cause death or serious injury.	Tensión peligrosa. Puede causar la muerte o lesiones graves.	Tension électrique. Danger de mort ou risque de blessures graves.
 Turn off and lock out all power supplying this device before working on this device.	Desconectar la alimentación eléctrica antes de trabajar en el equipo.	Mettre hors tension avant d'intervenir sur l'appareil.

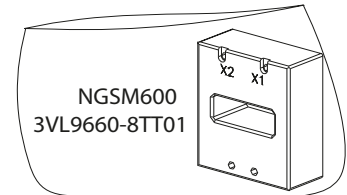
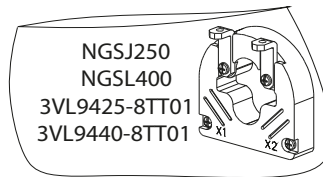

DE	Weiteres Zubehör
EN	Additional accessories
FR	Accessoires supplémentaires
ES	Otros accesorios
IT	Ulteriori accessori
PT	Acessório adicional
TR	Başka parçala
PY	Дополнительные приборы
中文	其他配件

Accessory
[Accesorio]

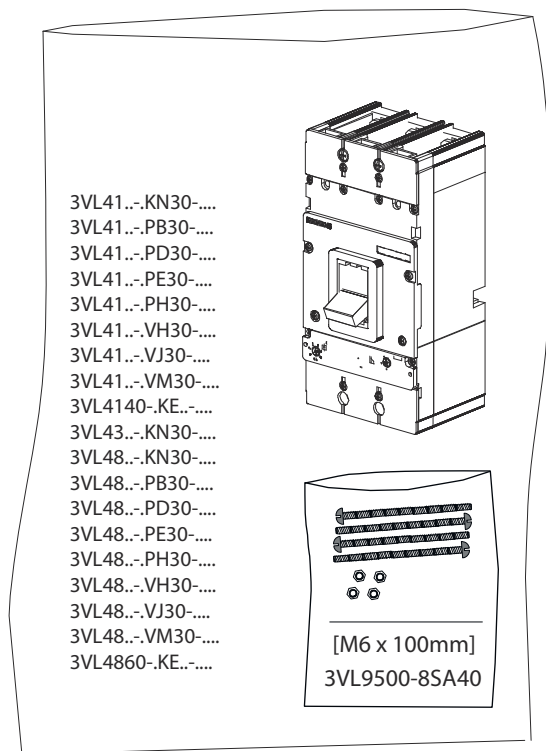
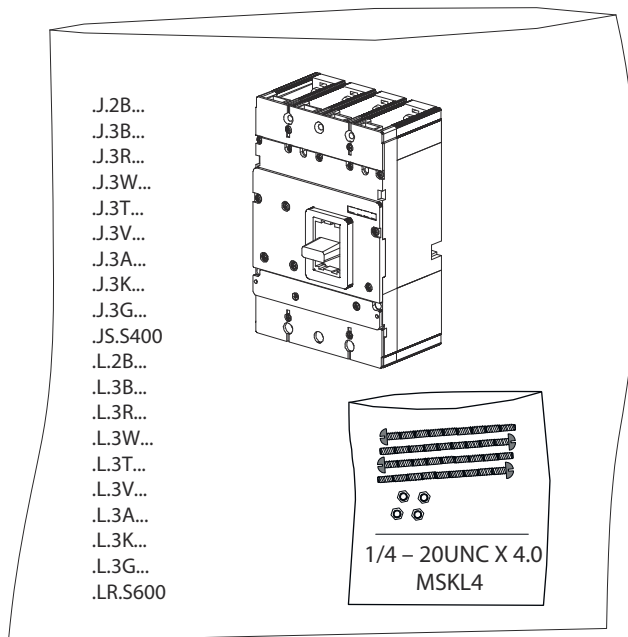

DE	Lieferumfang
EN	Quantity of delivery
FR	Composition de la fourniture
ES	Alcance del suministro
IT	Configurazione di forniture
PT	Escopo de fornecimento
TR	Teslimat hacmi
PY	Комплект поставки
中文	供货范围



⚠ DANGER	⚠ PELIGRO	⚠ DANGER
 Hazardous voltage. Will cause death or serious injury.	Tensión peligrosa. Puede causar la muerte o lesiones graves.	Tension électrique. Danger de mort ou risque de blessures graves.
 Turn off and lock out all power supplying this device before working on this device.	Desconectar la alimentación eléctrica antes de trabajar en el equipo.	Mettre hors tension avant d'intervenir sur l'appareil.

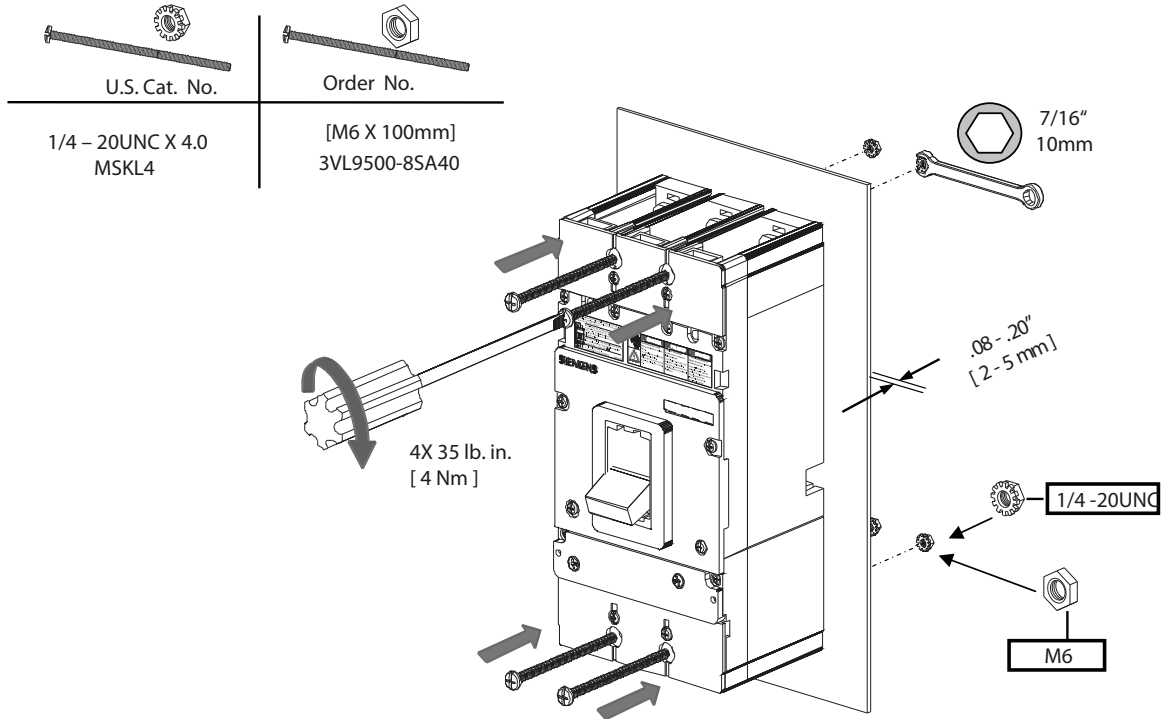

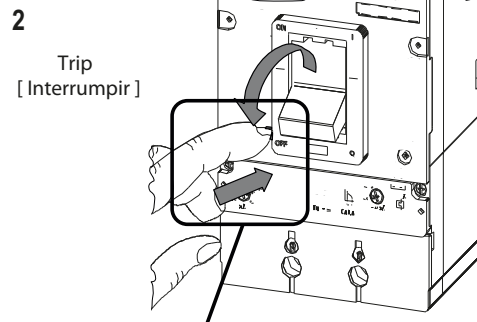
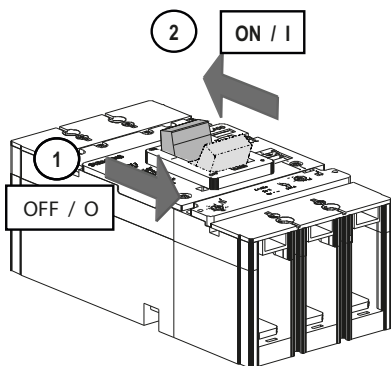

1 Test:
[Prueba:]

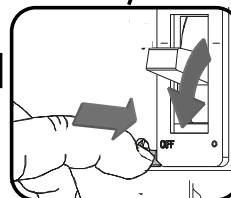

TRIPPED  → see Trip Unit 525, 555 and 586

TRIPPED  → <http://www.siemens.com/lowvoltage/technical-support>



⚠ DANGER	⚠ PELIGRO	⚠ DANGER
 Hazardous voltage. Will cause death or serious injury.	Tensión peligrosa. Puede causar la muerte o lesiones graves.	Tension électrique. Danger de mort ou risque de blessures graves.
 Turn off and lock out all power supplying this device before working on this device.	Desconectar la alimentación eléctrica antes de trabajar en el equipo.	Mettre hors tension avant d'intervenir sur l'appareil.

1 Test:
[Prueba:]

Trip Unit – 525- Test
[Disparador - 525 - Prueba]
.J..B...,
.L..B...,
3VL4...-K.30-....

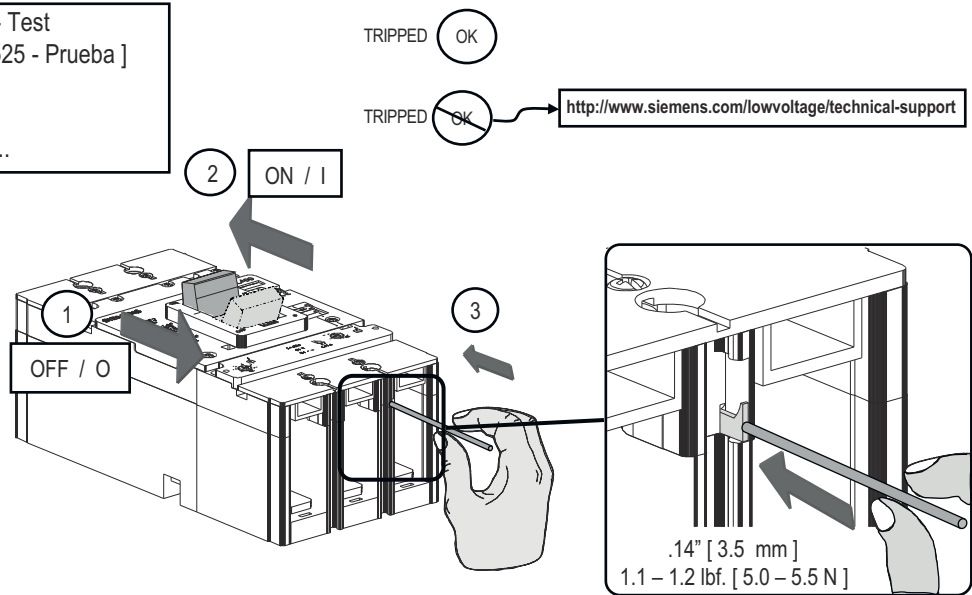

<http://www.siemens.com/lowvoltage/technical-support>

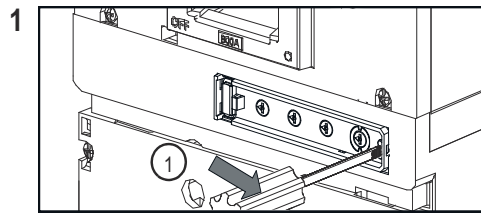

Trip Unit – 555- Test
[Disparador - 555 - Prueba]
.J.3R..., .J.3T...,
.J.3V..., .J.3W...,
.L.3R..., .L.3T...,
.L.3V..., .L.3W...,
3VL4...-P.30-....

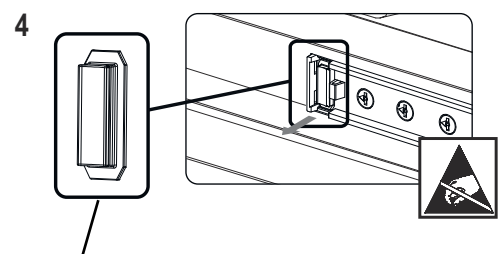
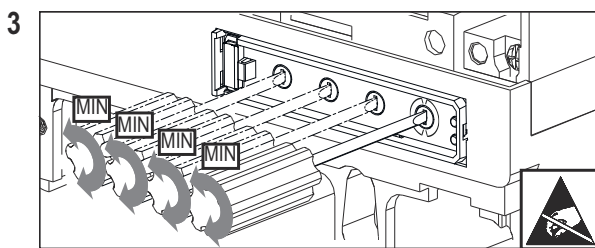
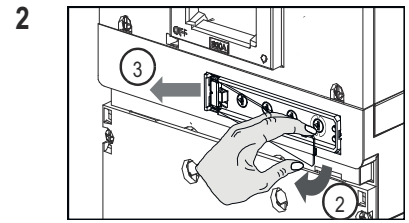

DE	Achtung	Vor Abnahme der Steckerabdeckung Leistungsschalter auf "OFF" schalten
EN	Caution	Place circuit breaker in "OFF" position before removing the plug cover
FR	Attention	Avant de retirer le cache du connecteur, positionner le disjoncteur sur "OFF"
ES	Atención	Ponga el interruptor automático en posición "OFF" antes de retirar la tapa del conector hembra
IT	Attenzione	Prima di rimuovere la copertura del connettore, portare l'interruttore automatico su "OFF"
PT	Atenção	Antes de retirar a cobertura do conector, mudar o disjuntor para "OFF".
TR	Dikkat	Fiş kapağını çıkarmadan önce güçşalterini "KAPALI" pozisyonuna getiriniz.
PY	Внимание	Перед снятием штекерной крышки установить силовой выключатель в положение "OFF" (ВЫКЛ)
中文	注意	在取下插头罩盖之前先要把断路器调到 "OFF" 位置

⚠ DANGER	⚠ PELIGRO	⚠ DANGER
 Hazardous voltage. Will cause death or serious injury. Turn off and lock out all power supplying this device before working on this device.	Tensión peligrosa. Puede causar la muerte o lesiones graves. Desconectar la alimentación eléctrica antes de trabajar en el equipo.	Tension électrique. Danger de mort ou risque de blessures graves. Mettre hors tension avant d'intervenir sur l'appareil.

5

Test:
[Prueba:]

*)

DE	Ausgelöst
EN	Tripped
FR	Déclenché
ES	Disparado
IT	Sganciato
PT	Disparado
TR	Çözülmüş durum
PY	Разомкнуто
中文	断开

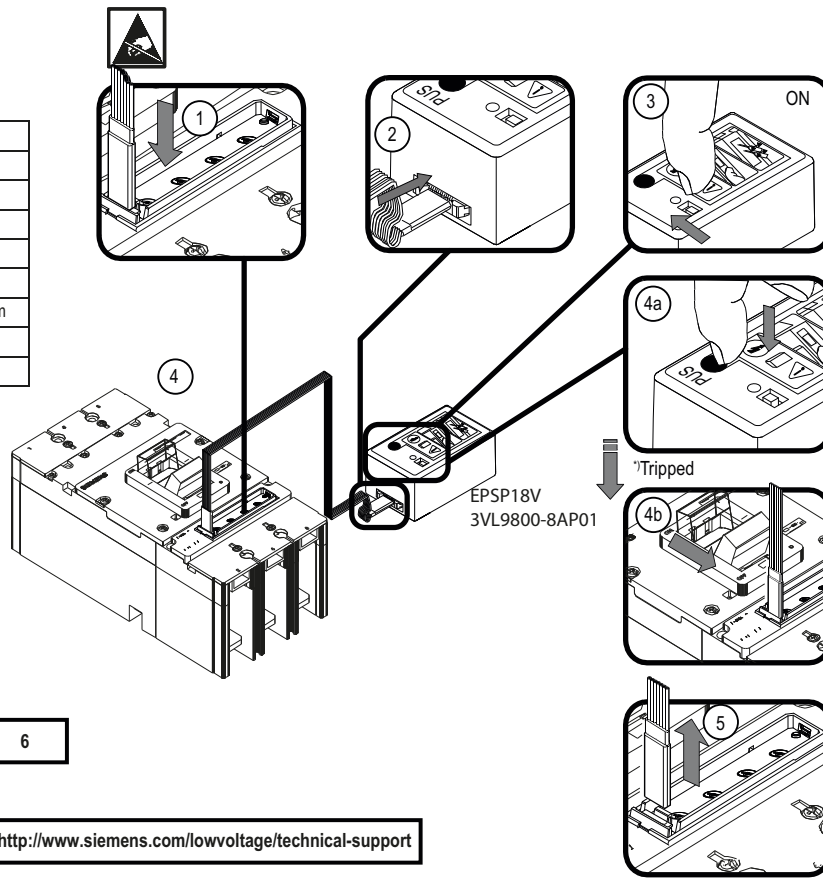

6

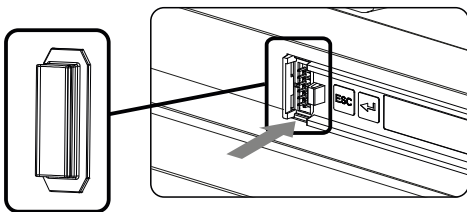

DE	Achtung	Vor dem Wiedereinschalten die Steckerabdeckung montieren
EN	Caution	Replace the plug cover before switching back on
FR	Attention	Avant de remettre sous tension, monter l'obturateur du connecteur
ES	Atención	Colocar la tapa del conector hembra antes de poner el interruptor en posición "ON"
IT	Attenzione	Prima della riattivazione montare la copertura del connettore
PT	Atenção	Antes de ligar novamente, montar a cobertura de conectores.
TR	Dikkat	Tekrar çalıştırmadan önce fiş kapağını monte ediniz.
PY	Внимание	Перед повторным включением установить штекерную крышку.
中文	注意	在重新接通电源前，要先安装插头罩盖。

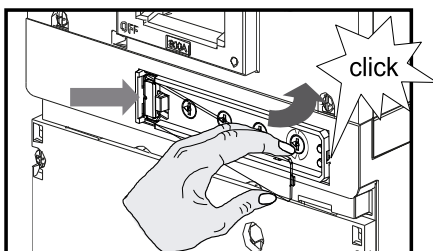

7

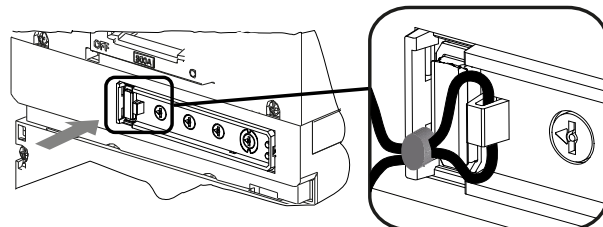

8





Option:
[Opción:]



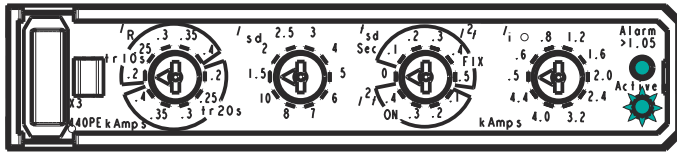





⚠ DANGER	⚠ PELIGRO	⚠ DANGER
 Hazardous voltage. Will cause death or serious injury.  Turn off and lock out all power supplying this device before working on this device.	Tensión peligrosa. Puede causar la muerte o lesiones graves. Desconectar la alimentación eléctrica antes de trabajar en el equipo.	Tension électrique. Danger de mort ou risque de blessures graves. Mettre hors tension avant d'intervenir sur l'appareil.

LED Operation States [LED Estado operación]



-  OFF / O
-  ON / I
-  ON / I -----
(Flashing)
[Intermitente]

Definitions / Definiciones	
In	Rated Current / Intensidad asignada
Ir	Continuous Amps / Amperios continuo
tr	Long Time Delay / Retardo largo
Isd	Short Time Pickup / Tiempo corto inicio
tsd	Short Time Delay / Retardo corto
li	Instantaneous Pickup / Instantánea inicio
Ig	Ground Fault Pickup / Inicio de falla a tierra
tg	Ground Fault Delay / Retardo de falla a tierra

Alarm LED [LED de Alarma]	Active LED [LED Activo]	System Status [Estado de sistema]	Device Status [Estado del dispositivo]
		$< 25\% \times I_n$	OK
		$> 25\% \times I_n$	Not OK Contact Technical Support [Lamar a Soporte Técnico] http://www.siemens.com/lowvoltage/technical-support
		$< 105\% \times I_r$	OK
		$> 105\% \times I_r$	OK
 Alternating [Alternando]		$> 25\% \times I_n$	*Minimum Setting [* Ajuste de Minimo] Contact Technical Support [Lamar a Soporte Técnico] http://www.siemens.com/lowvoltage/technical-support

* In event of damage to the device, Electronic Trip Units are equipped with a Minimum Setting feature. All settings override to the lowest possible value and the device must be replaced.

[* En caso de daño al aparato, la unidad de disparo esta equipada con una característica Ajuste de Minimo. Todos los ajuste se convierte al valor mas bajo posible y la unidad debe ser remplazada]

⚠ DANGER	⚠ PELIGRO	⚠ DANGER
Hazardous voltage. Will cause death or serious injury.  Turn off and lock out all power supplying this device before working on this device.	Tensión peligrosa. Puede causar la muerte o lesiones graves. Desconectar la alimentación eléctrica antes de trabajar en el equipo.	Tension électrique. Danger de mort ou risque de blessures graves. Mettre hors tension avant d'intervenir sur l'appareil.

1 Trip Unit – 586- Test
[Disparador - 586 - Prueba]
J.3A...,
J.3K...,
J.3G...,
.L.3A...,
.L.3K...,
.L.3G...,
3VL4...-V.30-....

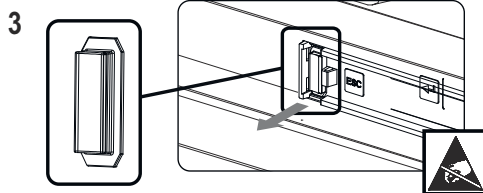
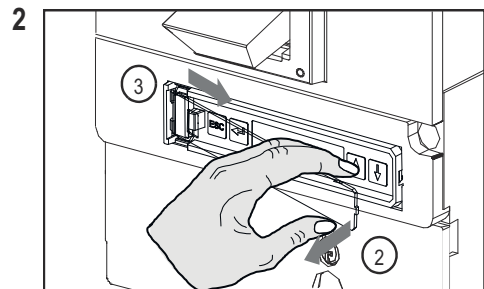
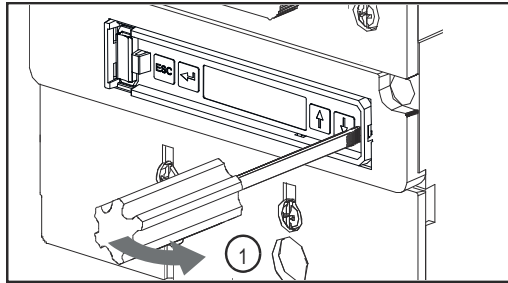

DE	Achtung	Vor Abnahme der Steckerabdeckung Leistungsschalter auf "OFF" schalten
EN	Caution	Place circuit breaker in "OFF" position before removing the plug cover
FR	Attention	Avant de retirer le cache du connecteur, positionner le disjoncteur sur "OFF"
ES	Atención	Ponga el interruptor automático en posición "OFF" antes de retirar la tapa del conector hembra
IT	Attenzione	Prima di rimuovere la copertura del connettore, portare l'interruttore automatico su "OFF"
PT	Atenção	Antes de retirar a cobertura do conector, mudar o disjuntor para "OFF".
TR	Dikkat	Fiş kapağını çıkarmadan önce güç şalterini "KAPALI" pozisyonuna getiriniz.
PY	Внимание	Перед снятием штекерной крышки установить силовой выключатель положение "OFF" ("ВЫКЛ")
中文	注意	在取下插头罩盖之前先要把断路器调到 "OFF" 位置

4

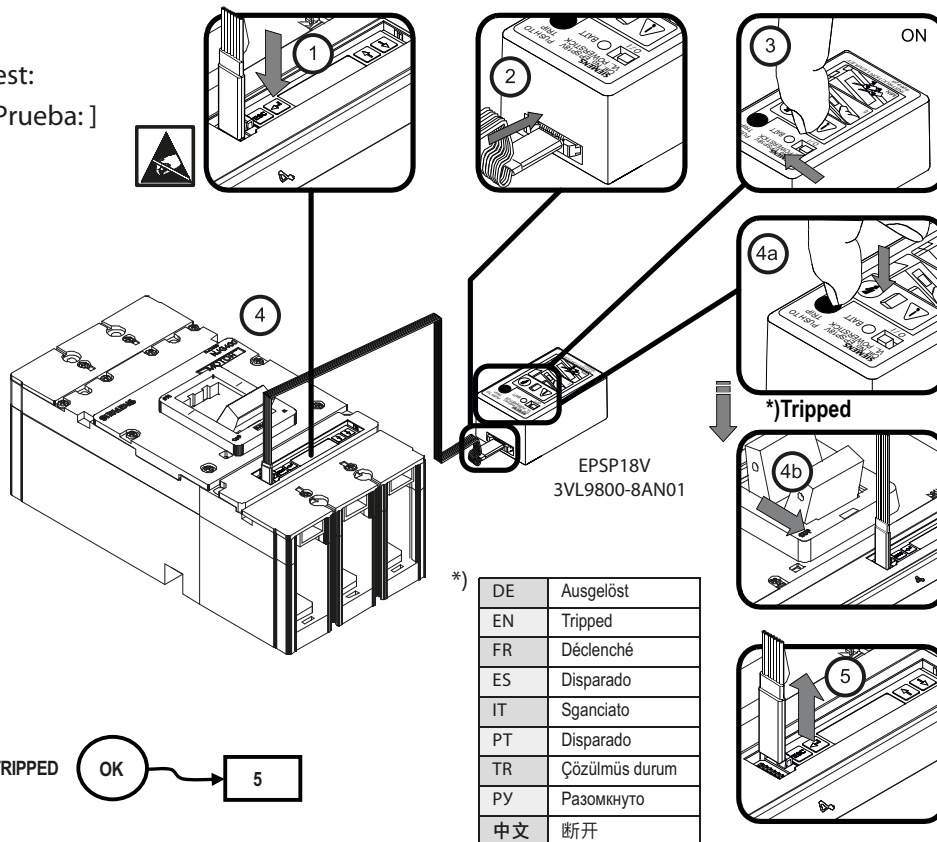

Test:
[Prueba:]



*)

DE	Ausgelöst
EN	Tripped
FR	Déclenché
ES	Disparado
IT	Sganciato
PT	Disparado
TR	Çözülmüş durum
PY	Разомкнуто
中文	断开



⚠ DANGER		⚠ PELIGRO		⚠ DANGER	
	Hazardous voltage. Will cause death or serious injury.	Tensión peligrosa. Puede causar la muerte o lesiones graves.		Tension électrique. Danger de mort ou risque de blessures graves.	
	Turn off and lock out all power supplying this device before working on this device.	Desconectar la alimentación eléctrica antes de trabajar en el equipo.		Mettre hors tension avant d'intervenir sur l'appareil.	

5

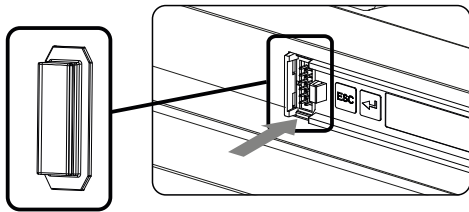

DE	Achtung	Vor dem Wiedereinschalten die Steckerabdeckung montieren
EN	Caution	Replace the plug cover before switching back on
FR	Attention	Avant de remettre sous tension, monter l'obturateur du connecteur
ES	Atención	Colocar la tapa del conector hembra antes de poner el interruptor en posición "ON"
IT	Attenzione	Prima della riattivazione montare la copertura del connettore
PT	Atenção	Antes de ligar novamente, montar a cobertura de conectores.
TR	Dikkat	Tekrar çalıştırmadan önce fiş kapağını monte ediniz.
РУ	Внимание	Перед повторным включением установить штекерную крышку.
中文	注意	在重新接通电源前，要先安装插头罩盖。

6

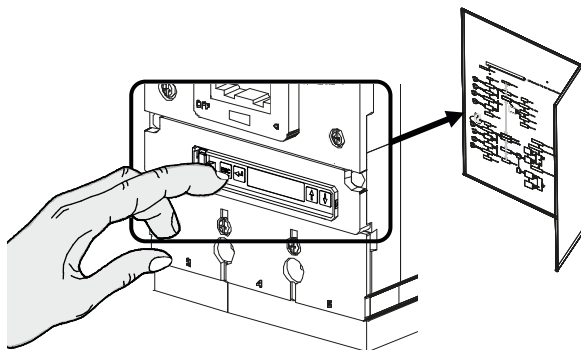

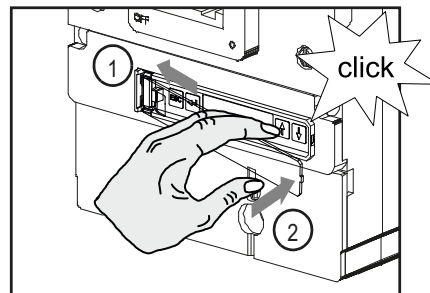

3ZW1012-OVL02-2AA0

7

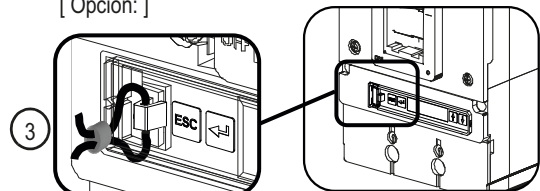

Option:
[Opción:]



⚠ DANGER	⚠ PELIGRO	⚠ DANGER
 Hazardous voltage. Will cause death or serious injury.	Tensión peligrosa. Puede causar la muerte o lesiones graves.	Tension électrique. Danger de mort ou risque de blessures graves.
 Turn off and lock out all power supplying this device before working on this device.	Desconectar la alimentación eléctrica antes de trabajar en el equipo.	Mettre hors tension avant d'intervenir sur l'appareil.



Operation States [Estado operación]

Definitions / Definiciones	
I_n	Rated Current / Intensidad asignada
I_r	Continuous Amps / Amperios continuo
t_r	Long Time Delay / Retardo largo
I_{sd}	Short Time Pickup / Tiempo corto inicio
t_{sd}	Short Time Delay / Retardo corto
I_i	Instantaneous Pickup / Instantánea inicio
I_g	Ground Fault Pickup / Inicio de falla a tierra
t_g	Ground Fault Delay / Retardo de falla a tierra

LCD Display [Pantalla LCD]	System Status [Estado de sistema]	Device Status [Estado del dispositivo]
	$< 25\% \times I_n$	OK
	$> 25\% \times I_n$	Not OK Contact Technical Support [Lamar a Soporte Técnico] http://www.siemens.com/lowvoltage/technical-support
A = XXXX B = XXXX C = XXXX N = XXXX	$\geq 25\% \times I_n$ $< 105\% \times I_r$	OK
Phase X Overload	$\geq 25\% \times I_n$ $> 105\% \times I_r$	OK
WARNING !!! INVALID COM	$> 25\% \times I_n$ Wrong COM2x release connected; Connect "COM2x Release 2" (or newer)	May Not Be Operated, Last Selected Settings
TRIP UNIT MEMORY ERROR	$> 25\% \times I_n$	*Minimum Setting [* Ajuste de Minimo] Contact Technical Support [Lamar a Soporte Técnico] http://www.siemens.com/lowvoltage/technical-support
TRIP UNIT EEPROM ERROR	$> 25\% \times I_n$	Not OK Contact Technical Support [Lamar a Soporte Técnico] http://www.siemens.com/lowvoltage/technical-support
TRIP UNIT OVER TEMPERATURE	$> 25\% \times I_n$	Not OK Contact Technical Support [Lamar a Soporte Técnico] http://www.siemens.com/lowvoltage/technical-support

* In event of damage to the device, Electronic Trip Units are equipped with a Minimum Setting feature. All settings override to the lowest possible value and the device must be replaced.

[* En caso de daño al aparato, la unidad de disparo esta equipada con una característica de Ajuste de Minimo. Todos los ajuste se convierte al valor mas bajo posible y la unidad debe ser remplazada.]

⚠ DANGER		⚠ PELIGRO		⚠ DANGER	
	Hazardous voltage. Will cause death or serious injury.	Tensión peligrosa. Puede causar la muerte o lesiones graves.		Tension électrique. Danger de mort ou risque de blessures graves.	
	Turn off and lock out all power supplying this device before working on this device.	Desconectar la alimentación eléctrica antes de trabajar en el equipo.		Mettre hors tension avant d'intervenir sur l'appareil.	

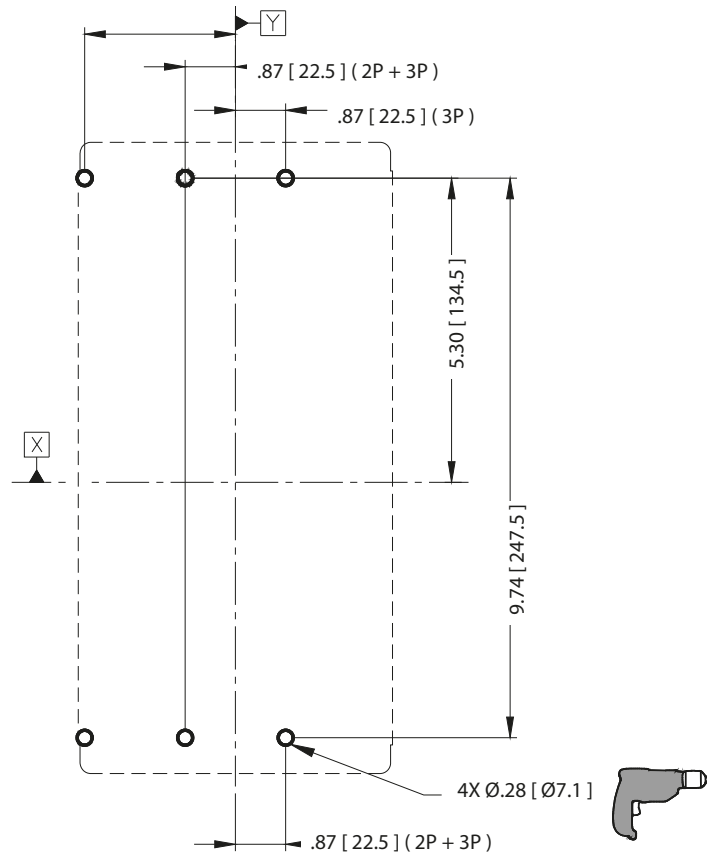

⚠ DANGER	⚠ PELIGRO	⚠ DANGER
Hazardous voltage. Will cause death or serious injury.	Tensión peligrosa. Puede causar la muerte o lesiones graves.	Tension électrique. Danger de mort ou risque de blessures graves.
Turn off and lock out all power supplying this device before working on this device.	Desconectar la alimentación eléctrica antes de trabajar en el equipo.	Mettre hors tension avant d'intervenir sur l'appareil.

Not Vented
[No Ventilados]
Cat. No.

NJG.....
HJG.....
LJG.....
NJX.....
HJX.....
LJX.....

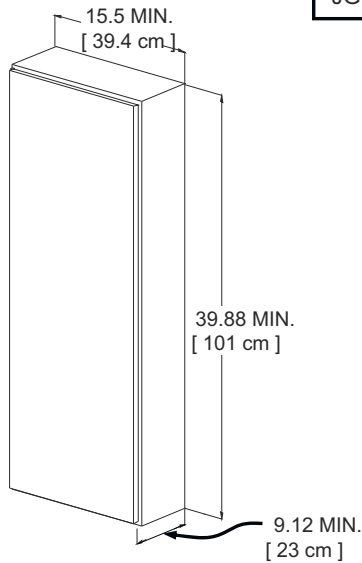

JG

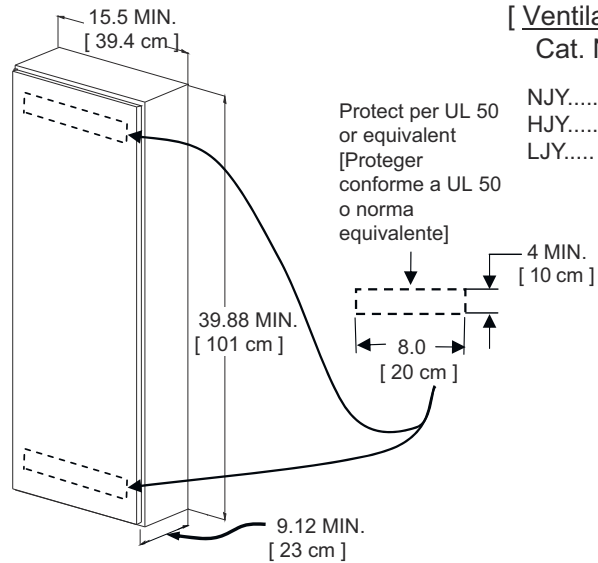

Vented
[Ventilados]
Cat. No.

NJY.....
HJY.....
LJY.....

Suitable for continuous operation at 100% of rating only if used in a ventilated enclosure or cubicle space 39.88 by 15.5 by 9.12 inches MIN. with ventilated openings 4 by 8 inches at top and bottom. Openings should be located at least 9 inches from the ends of the breaker.

Adecuado para operación continua a 100% de la capacidad; solamente si se instala en un compartimento ventilado de por lo menos 39.88 x 15.5 x 9.12 pulgadas (mínimo). El compartimento debe tener dos aberturas de 4 x 8 pulgadas; una en la parte inferior y otra en la parte superior. Estas aberturas deben estar localizadas por lo menos a 9 pulgadas de los extremos del interruptor.

Not Vented
[No Ventilados]
Cat. No.

NLK.....
HLK.....
LLK.....

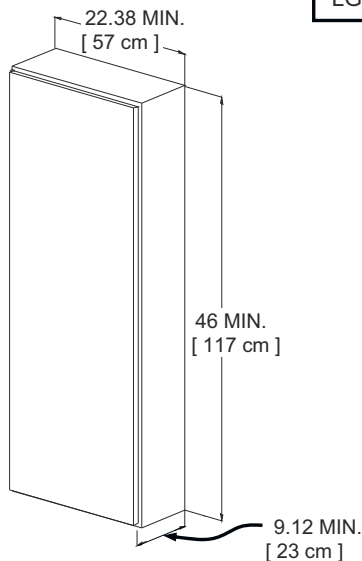

LG

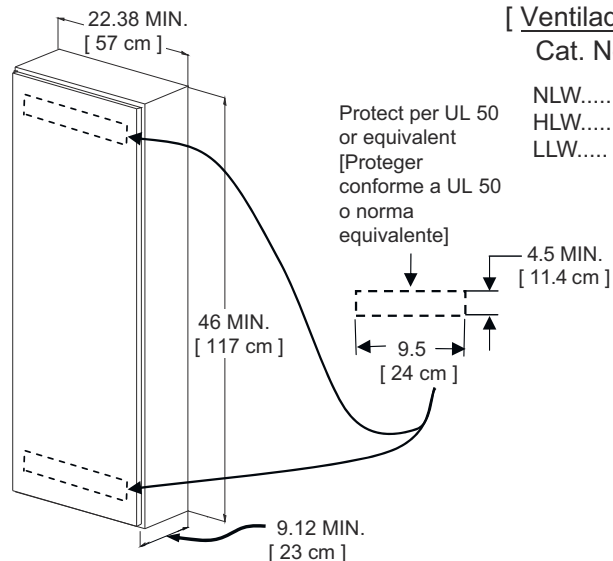



Vented
[Ventilados]
Cat. No.

NLW.....
HLW.....
LLW.....

Suitable for continuous operation at 100% of rating only if used in a ventilated enclosure or cubicle space 46 by 22.38 by 9.12 inches MIN. with ventilated openings 4.5 by 9.5 inches at top and bottom. Openings should be located at least 9 inches from the ends of the breaker.

Adecuado para operación continua a 100% de la capacidad; solamente si se instala en un compartimento ventilado de por lo menos 46 x 22.38 x 9.12 pulgadas (mínimo). El compartimento debe tener dos aberturas de 4.5 x 9.5 pulgadas; una en la parte inferior y otra en la parte superior. Estas aberturas deben estar localizadas por lo menos a 9 pulgadas de los extremos del interruptor.

⚠ DANGER	⚠ PELIGRO	⚠ DANGER
 Hazardous voltage. Will cause death or serious injury.  Turn off and lock out all power supplying this device before working on this device.	Tensión peligrosa. Puede causar la muerte o lesiones graves. Desconectar la alimentación eléctrica antes de trabajar en el equipo.	Tension électrique. Danger de mort ou risque de blessures graves. Mettre hors tension avant d'intervenir sur l'appareil.

Option [Opción]

3VL41... - .P... -
 3VL41... - .V... -
 3VL48... - .P... -
 3VL48... - .V... -
 .J.3R...
 .J.3W...
 .J.3T...
 .J.3V...
 .J.3A...
 .J.3K...
 .J.3G...
 .L.3R...
 .L.3W...
 .L.3T...
 .L.3V...
 .L.3A...
 .L.3K...
 .L.3G...

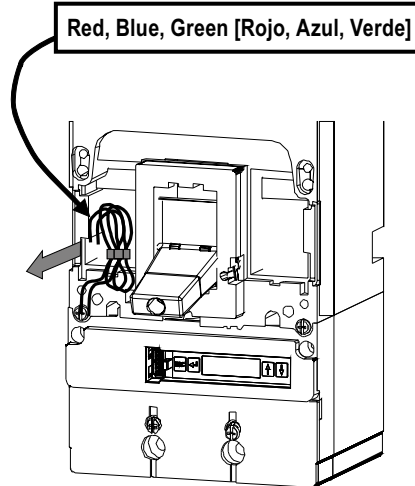

Note

Red, blue and green wire is required for communication via COM20/21. Wires maybe cut if communication is not planned. Details see operating instructions 3ZW1012-1VL00-2AA0

Nota

Los conductores rojo, azul y verde son necesarios para la comunicación vía COM20/21. Estos conductores pueden estar contados sin no está prevista dicha comunicación. Para detalles, ver las instrucciones 3ZW1012-1VL00-2AA0

DE	Weitere Informationen finden Sie im 3VL-Handbuch im Internet unter: www.siemens.com/lowvoltage/manuals www.usa.siemens.com/powerdistribution (nur in Deutsch und Englisch)
EN	Further information can be found in the 3VL manual on the internet at www.siemens.com/lowvoltage/manuals www.usa.siemens.com/powerdistribution (only in German and English)
FR	Vous trouverez des informations supplémentaires dans le manuel 3VL sur le site Internet www.siemens.com/lowvoltage/manuals www.usa.siemens.com/powerdistribution (seulement en allemand et en anglais)
ES	Para más información, consulte el manual 3VL que está disponible en nuestra página web www.siemens.com/lowvoltage/manuals www.usa.siemens.com/powerdistribution (sólo en alemán e inglés)
IT	Ulteriori informazioni sono disponibili in Internet nel manuale 3VL su www.siemens.com/lowvoltage/manuals www.usa.siemens.com/powerdistribution (solo in tedesco e in inglese)
PT	Mais informações encontram-se no manual 3VL na Internet, sob www.siemens.com/lowvoltage/manuals www.usa.siemens.com/powerdistribution (somente em alemão e em inglês)
TR	Ayrıntılı bilgiyi aşağıdaki internet adresindeki 3VL kullanma kılavuzundan edinebilirsiniz: www.siemens.com/lowvoltage/manuals www.usa.siemens.com/powerdistribution (sadece Almanca ve İngilizce olarak)
PY	Дальнейшую информацию Вы сможете найти в инструкции по эксплуатации 3VL в интернете по адресу: www.siemens.com/lowvoltage/manuals www.usa.siemens.com/powerdistribution (только на немецком и английском языке)
中文	其他相关信息参见 3VL 使用手册，请登陆互联网： www.siemens.com/lowvoltage/manuals www.usa.siemens.com/powerdistribution (德、英文)