

SIEMENS

Max - Flex™ Operators
 Operadores Max-Flex™
 Opérateurs Max-Flex™

U.S. Cat. No.	Euro Order No.	U.S. Cat. No.	Euro Order No.	U.S. Cat. No.	Euro Order No.
Item: MFML	3VL9400-3JN01	MFCM060	3VL9600-3JQ61	MFHM3R	3VL9600-3JP01
MFMM	3VL9600-3JN01	MFCM072	3VL9600-3JQ71	MFHM3RB	3VL9600-3JP11
MFKL3R	3VL9400-3JM01	MFCM084	3VL9600-3JQ81	MFHM3RSB	3VL9600-3JP61
MFKM3R	3VL9600-3JM01	MFCM096	3VL9600-3JQ91	MFHM3RS	3VL9600-3JP21
MFCM036	3VL9600-3JQ31	MFCM120	3VL9600-3JQ01	MFHM4X	3VL9600-3JP41
MFCM048	3VL9600-3JQ41	MFCM144	3VL9600-3JQ11		

For Use With Frame JG, LG, MG
 Para Usar Con Caja Base JG, LG, MG

Installation Instructions / Instructivo de Instalación

	 Danger	 Peligro	 Danger
	Hazardous Voltage. Will cause death or serious injury. Turn off and lock out all power supplying this device before working on this device. Replace all covers before power supplying this device is turned on.	Tensión peligrosa. Puede causar la muerte o lesiones graves. Desenergice totalmente antes de instalar o darle servicio. Reemplace todas las barreras y cubiertas antes de energizar el interruptor.	Tension dangereuse. Danger de mort ou risque de blessures graves. Couper l'alimentation de l'appareil et barrer avant de travailler. Remplacez tous les couverts avant que l'approvisionnement de pouvoir soit alimenté.

Use only with Siemens certified Components.
 Utilizar únicamente con componentes certificados de Siemens.
 A utiliser uniquement avec les composants certifiés Siemens.

MFHM3R	Suitable For Type 1,3,3R,4,12,12K enclosures [Apto par tipo 1,3,3R,4,12,12K caja]
MFHM3RB	Suitable For Type 1,3,3R,4,12,12K enclosures [Apto par tipo 1,3,3R,4,12,12K caja]
MFHM3RS	Suitable For Type 1,2,3,3R,12,12K, 13 enclosures [Apto par tipo 1,2,3,3R,12,12K, 13 caja]
MFHM3RSB	Suitable For Type 1,2,3,3R,12,12K,13 enclosures [Apto par tipo 1,2,3,3R,12,12K,13 caja]
MFHM4X	Suitable For Type 1,2,3,3R,4,4X,12,12K,13 enclosures [Apto par tipo 1,2,3,3R,4,4X,12,12K,13 caja]

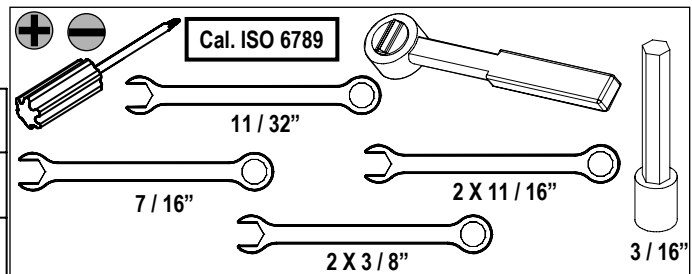

See pages 5/16 , 6/16, 7/16
 for handle installation
 [Ver la páginas 5/16, 6/16, 7/16
 para instalar manija]

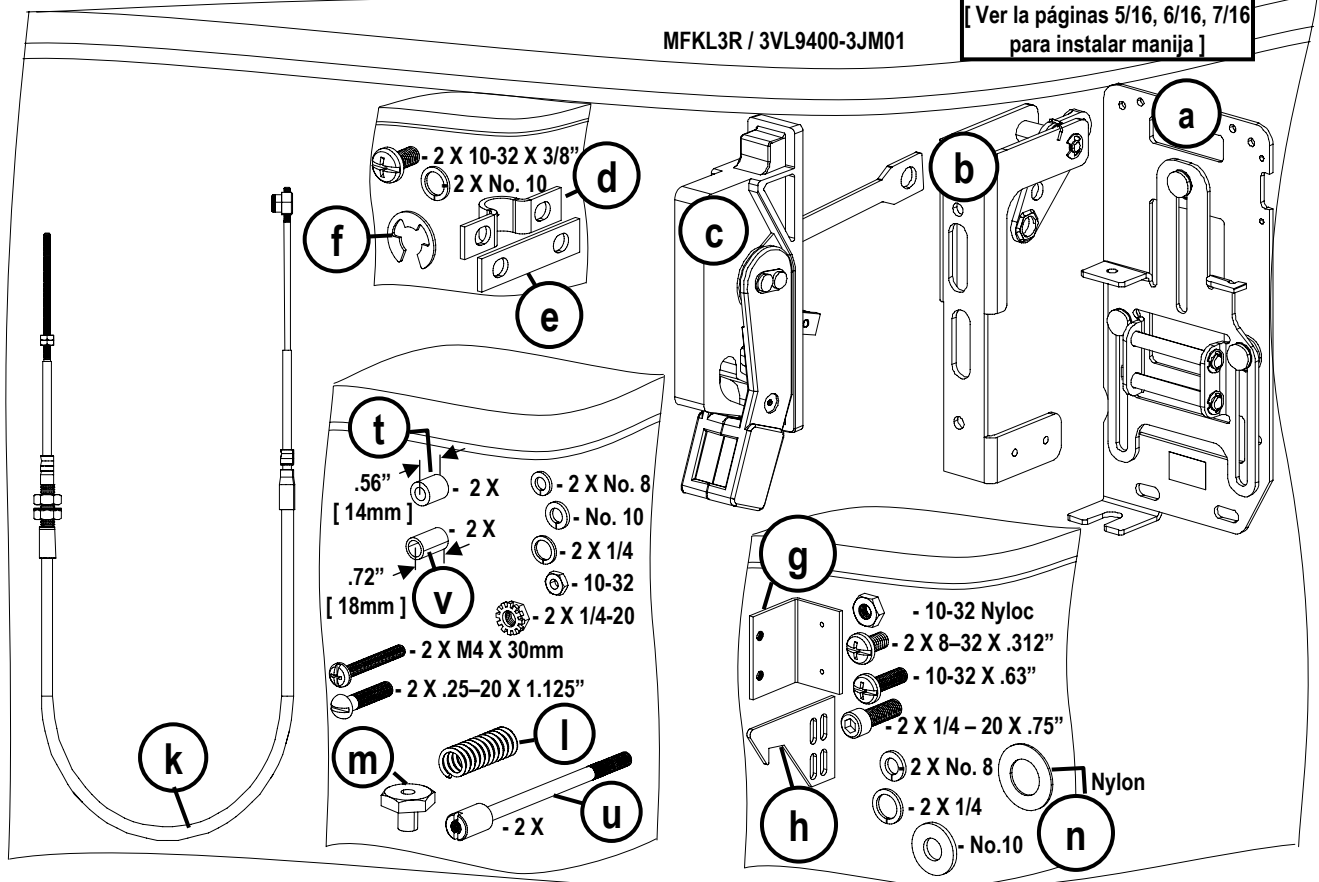



⚠ Danger

Hazardous Voltage.
Will cause death or serious injury.

Turn off and lock out all power supplying this device before working on this device.
Replace all covers before power supplying this device is turned on.

⚠ Peligro

Tensión peligrosa.
Puede causar la muerte o lesiones graves.

Desenergice totalmente antes de instalar o darle servicio.
Reemplace todas las barreras y cubiertas antes de energizar el interruptor.

⚠ Danger

Tension dangereuse.
Danger de mort ou risque de blessures graves.

Couper l'alimentation de l'appareil et barrer avant de travailler.
Remplacez tous les couverts avant que l'alprovisionnement de pouvoir soit alimenté.

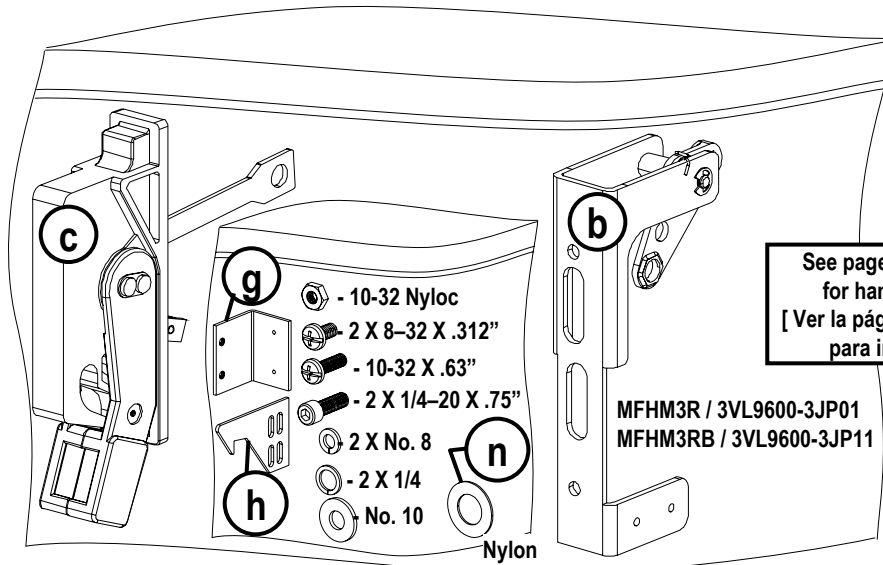

See pages 5/16 , 6/16, 7/16
for handle installation
[Ver la páginas 5/16, 6/16, 7/16
para instalar manija]

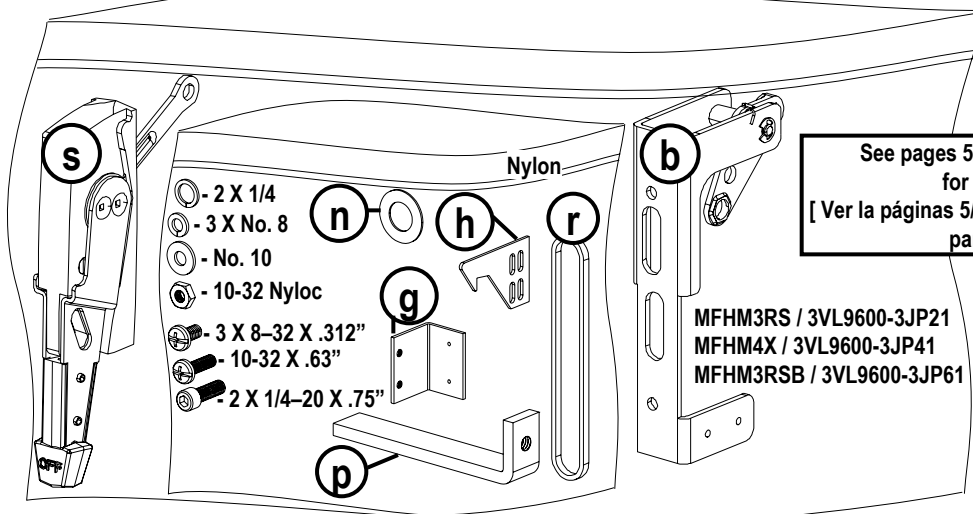
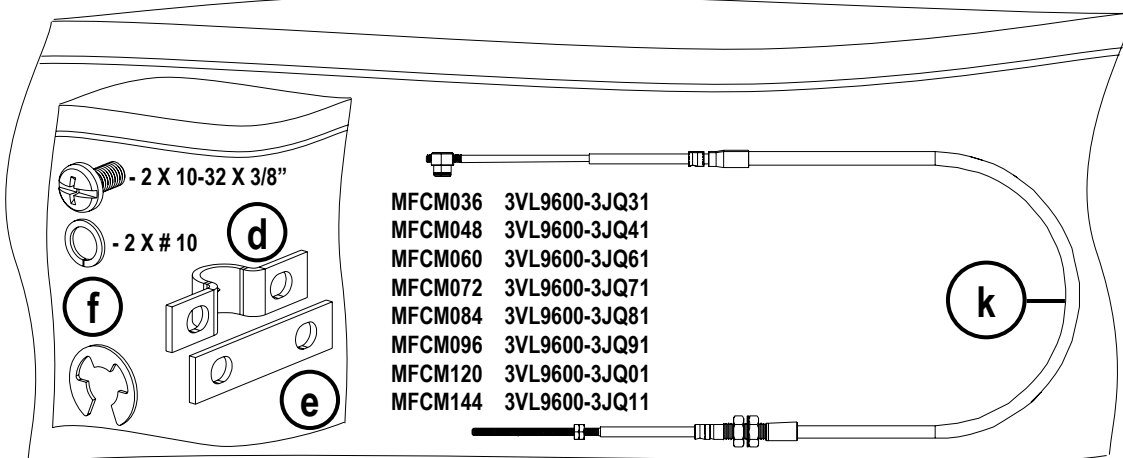

See pages 5/16 step 4 , 6/16 step 5, 8/14
for handle installation
[Ver la páginas 5/16 paso 4, 6/16 paso 5, 8/16, 9/16
para instalar manija]

**Dimensions for Welded or Screw mounting the cover catch.
[Dimensiones para soldar o atornillar el seguro de la puerta.]**

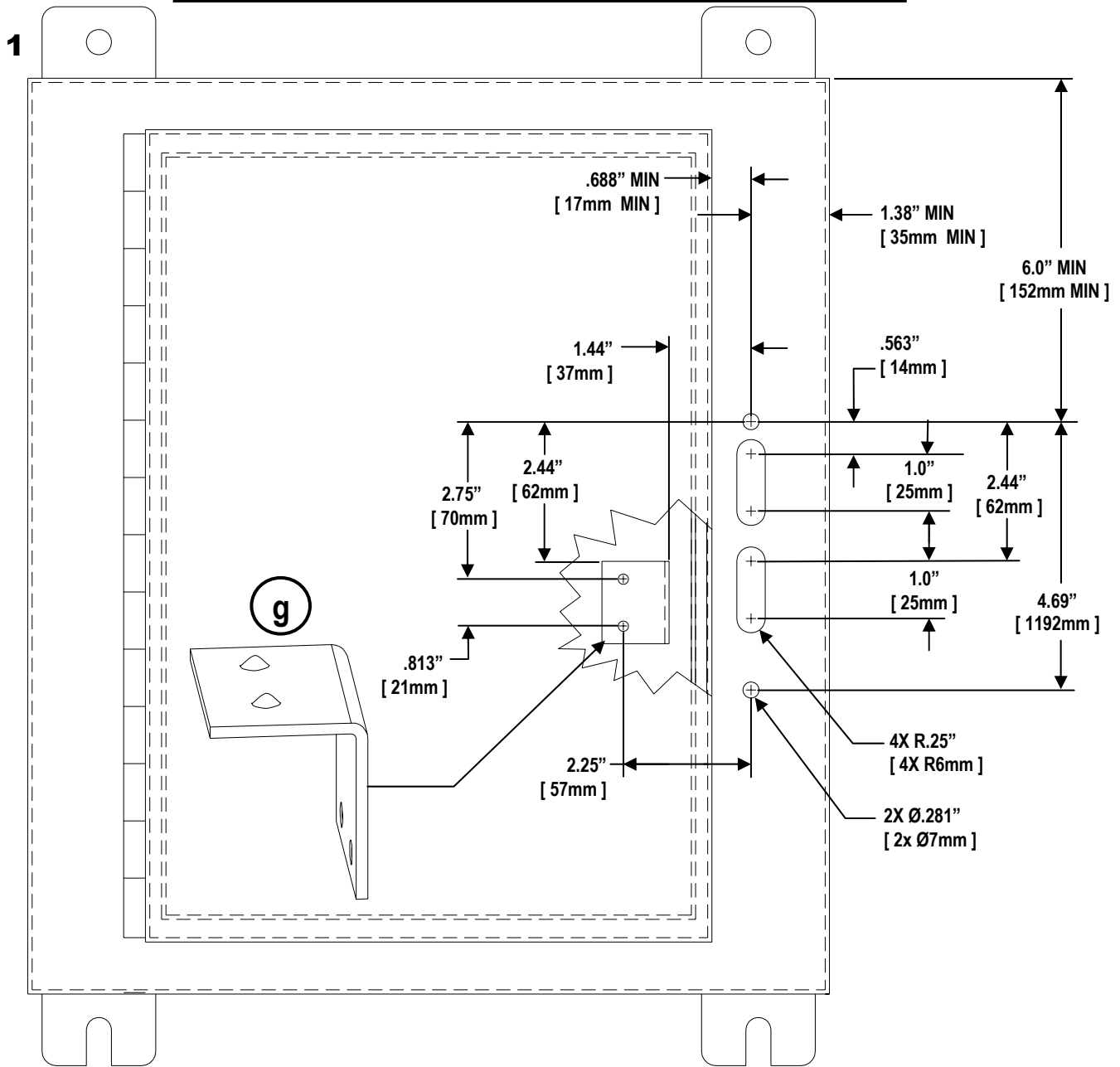

**Option:
[Opción:]**

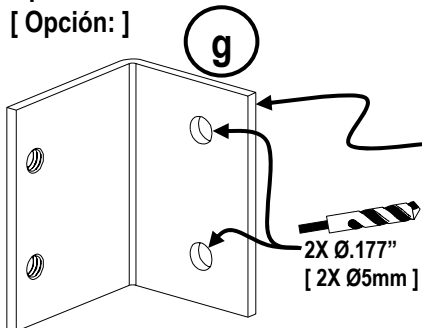

Customer supplied hardware for screw mounting option. Hardware must maintain environmental integrity (NEMA rating) of the enclosure.
[Material de montaje provisto por el cliente. Montaje por tornillo el material para montaje debe mantener la integridad ambiental (la grado NEMA) en la caja.]

2X Ø.177"
[2X Ø5mm]

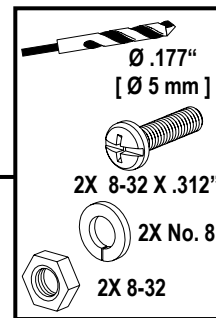

Ø .177"
[Ø 5 mm]
2X 8-32 X .312"
2X No. 8
2X 8-32



⚠ Danger

Hazardous Voltage.
Will cause death or serious injury.
 Turn off and lock out all power supplying this device before working on this device.
 Replace all covers before power supplying this device is turned on.

⚠ Peligro

Tensión peligrosa.
Puede causar la muerte o lesiones graves.
 Desenergice totalmente antes de instalar o darle servicio.
 Reemplace todas las barreras y cubiertas antes de energizar el interruptor.

⚠ Danger

Tension dangereuse.
Danger de mort ou risque de blessures graves.
 Couper l'alimentation de l'appareil et barrer avant de travailler.
 Remplacez tous les couverts avant que l'alimentation de pouvoir soit alimenté.

2

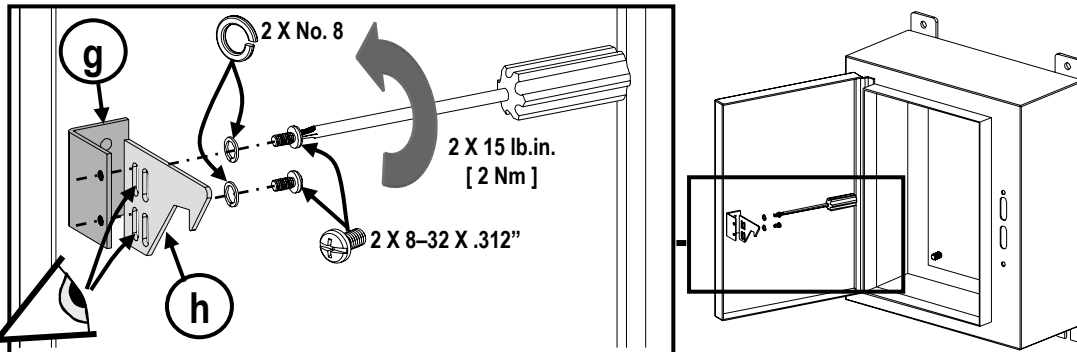

3

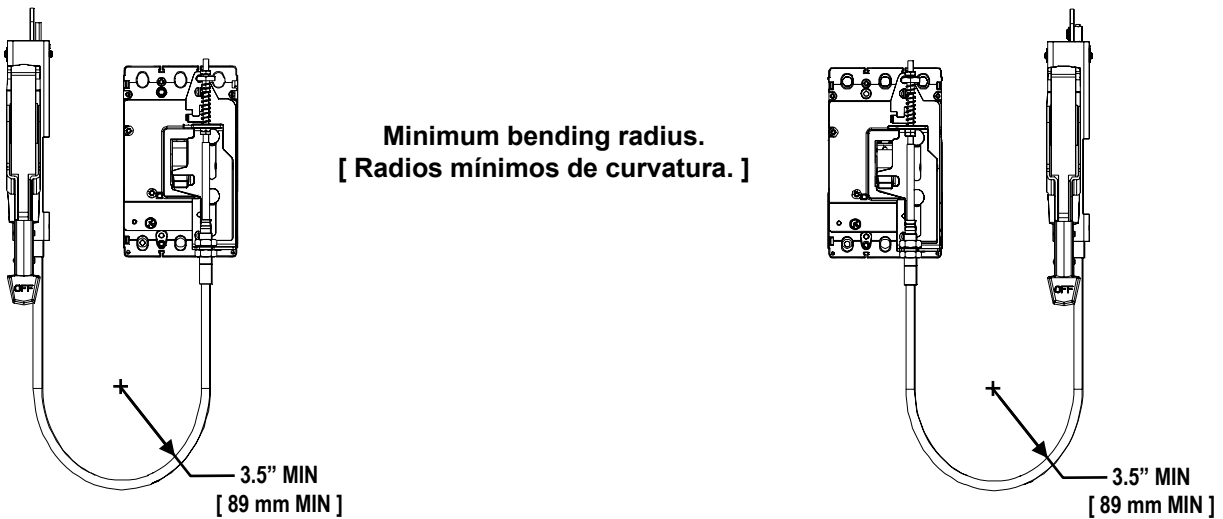

For left hand side mounting and right hand side mounting
[Para montaje de lado izquierdo y lado derecho]

- MFKL3R / 3VL9400-3JM01
- MFKM3R / 3VL9600-3JM01
- MFHM3R / 3VL9600-3JP01
- MFHM3RB / 3VL9600-3JP11
- MFHM3RSB / 3VL9600-3JP61
- MFHM3RS / 3VL9600-3JP21
- MFHM4X / 3VL9600-3JP41

4

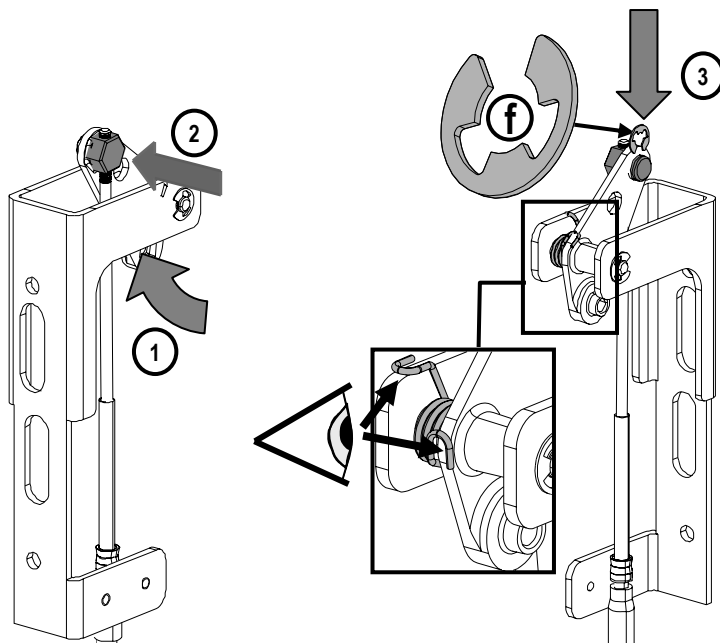
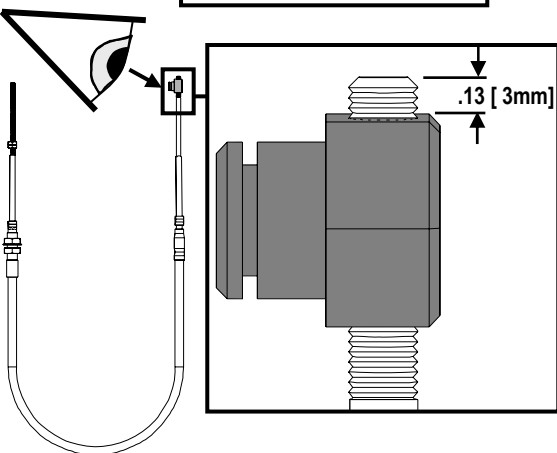

5

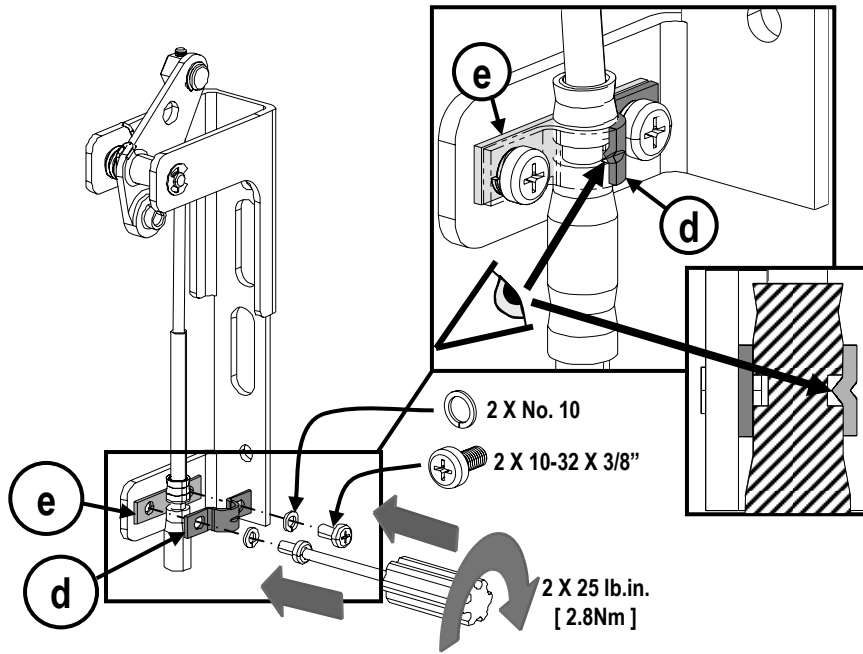

left hand side mounting
[Montaje de lado izquierdo]

MFKL3R / 3VL9400-3JM01
MFKM3R / 3VL9600-3JM01
MFHM3R / 3VL9600-3JP01
MFHM3RB / 3VL9600-3JP11

right hand side mounting
[Montaje de lado derecho]

6

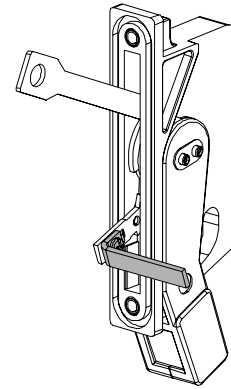
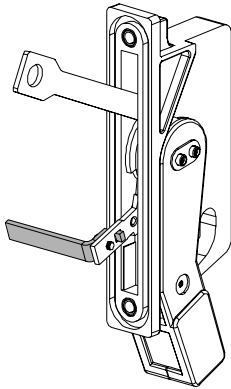

7

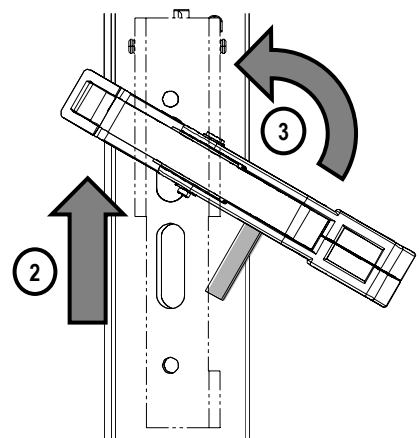
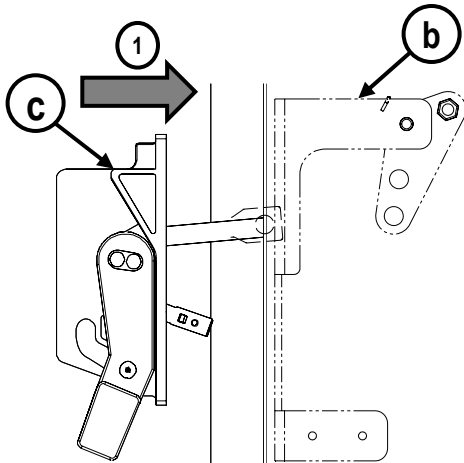



⚠ Danger

Hazardous Voltage.
Will cause death or serious injury.

Turn off and lock out all power supplying this device before working on this device.
Replace all covers before power supplying this device is turned on.



⚠ Peligro

Tensión peligrosa.
Puede causar la muerte o lesiones graves.

Desenergice totalmente antes de instalar o darle servicio.
Reemplace todas las barreras y cubiertas antes de energizar el interruptor.

⚠ Danger

Tension dangereuse.
Danger de mort ou risque de blessures graves.

Couper l'alimentation de l'appareil et barrer avant de travailler.
Remplacez tous les couverts avant que l'alimentation de pouvoir soit alimenté.

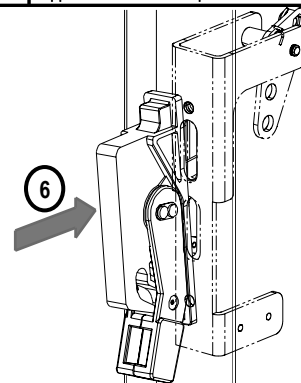
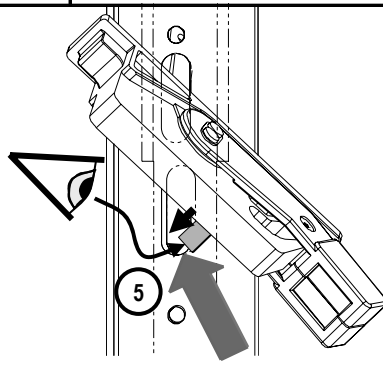
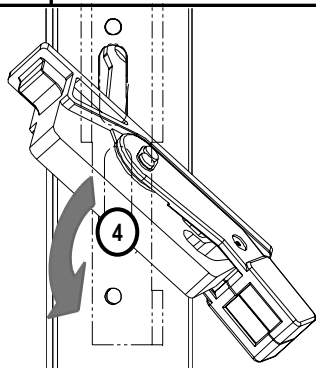

8 Enclosure removed for clarity [Caja removida por claridad]

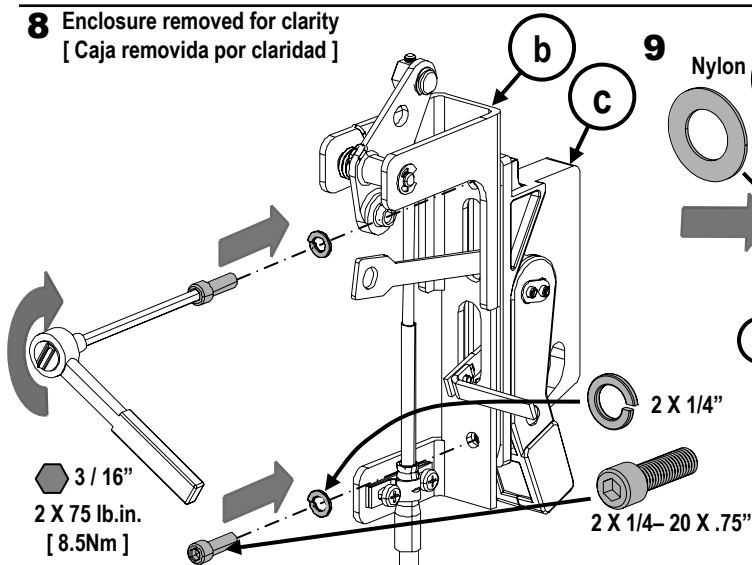

Enclosure removed for clarity [Caja removida por claridad]

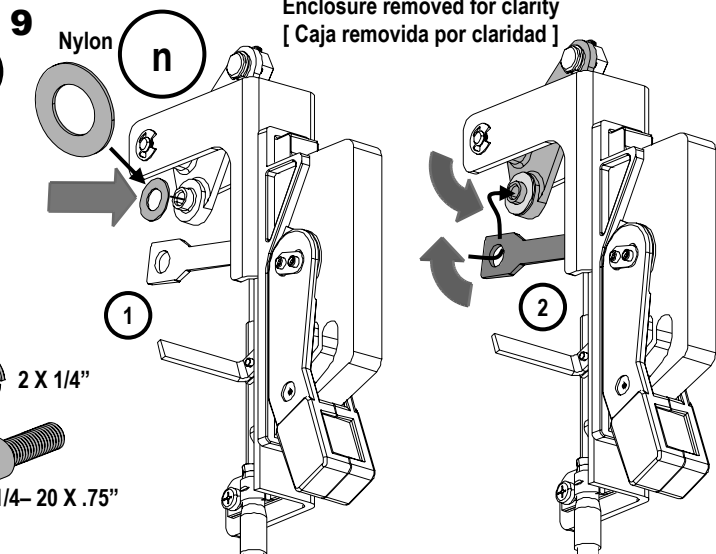

10 left hand side mounting [Montaje de lado izquierdo]

Enclosure removed for clarity
[Caja removida por claridad]

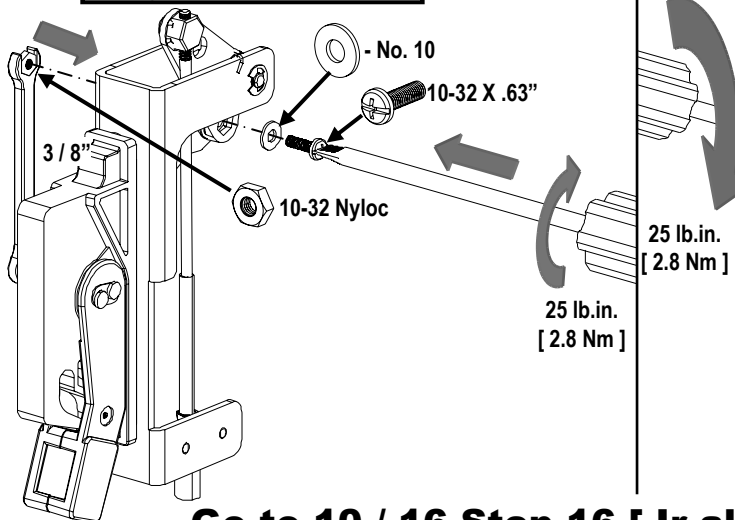

right hand side mounting [Montaje de lado derecho]

Enclosure removed for clarity
[Caja removida por claridad]

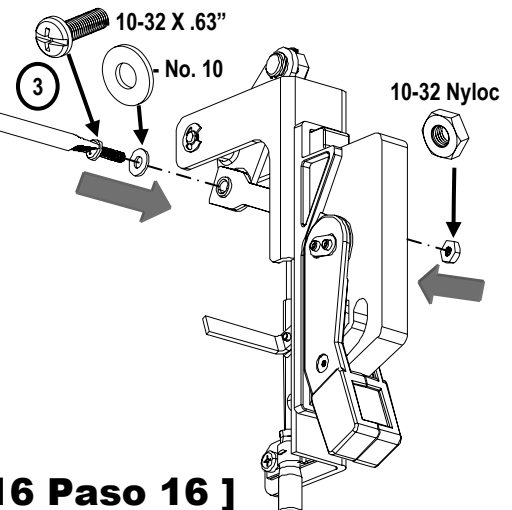

Go to 10 / 16 Step 16 [Ir al 10 / 16 Paso 16]

MFHM3RS / 3VL9600-3JP21
 MFHM4X / 3VL9600-3JP41
 MFHM3RSB / 3VL9600-3JP61

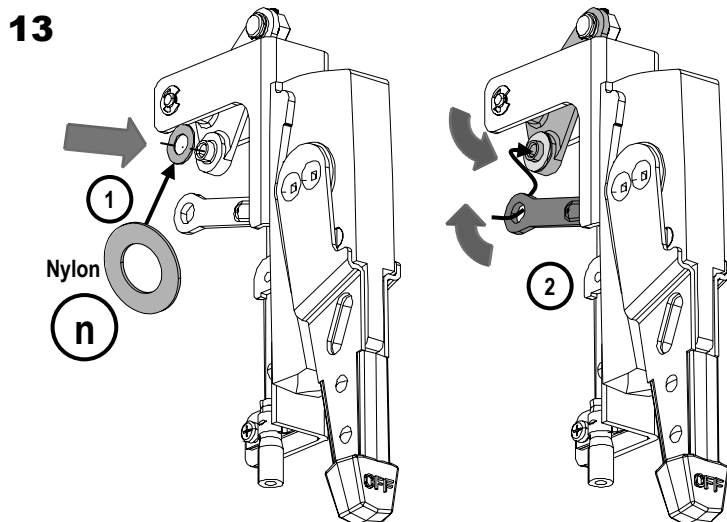
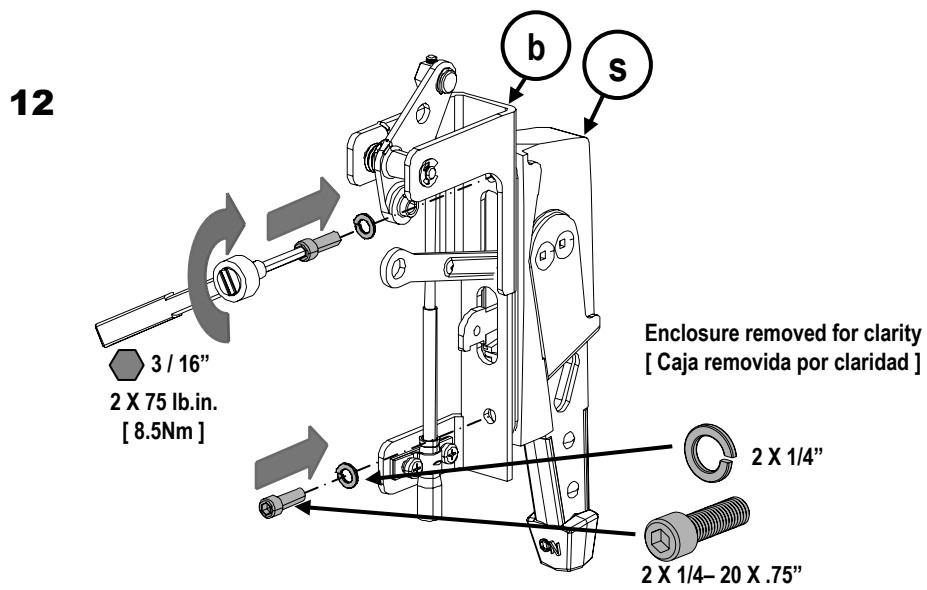
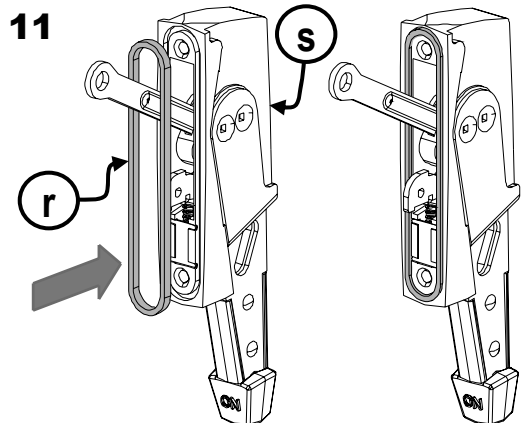



Danger

Hazardous Voltage.
Will cause death or serious injury.

Turn off and lock out all power supplying this device before working on this device.
Replace all covers before power supplying this device is turned on.

Peligro

Tensión peligrosa.
Puede causar la muerte o lesiones graves.

Desenergice totalmente antes de instalar o darle servicio.
Reemplace todas las barreras y cubiertas antes de energizar el interruptor.

Danger

Tension dangereuse.
Danger de mort ou risque de blessures graves.

Couper l'alimentation de l'appareil et barrer avant de travailler.
Remplacez tous les couverts avant que l'approvisionnement de pouvoir soit alimenté.

14

left hand side mounting
[Montaje de lado izquierdo]

Enclosure removed for clarity
[Caja removida por claridad]

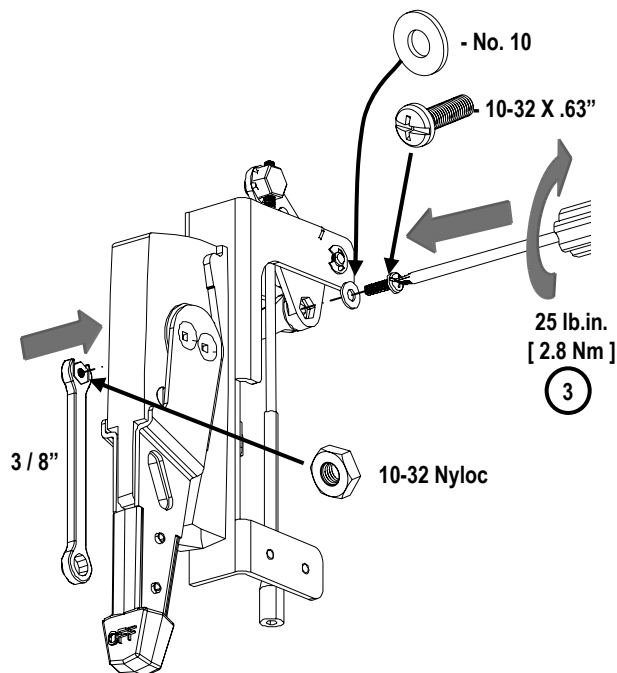

Enclosure removed for clarity
[Caja removida por claridad]

15

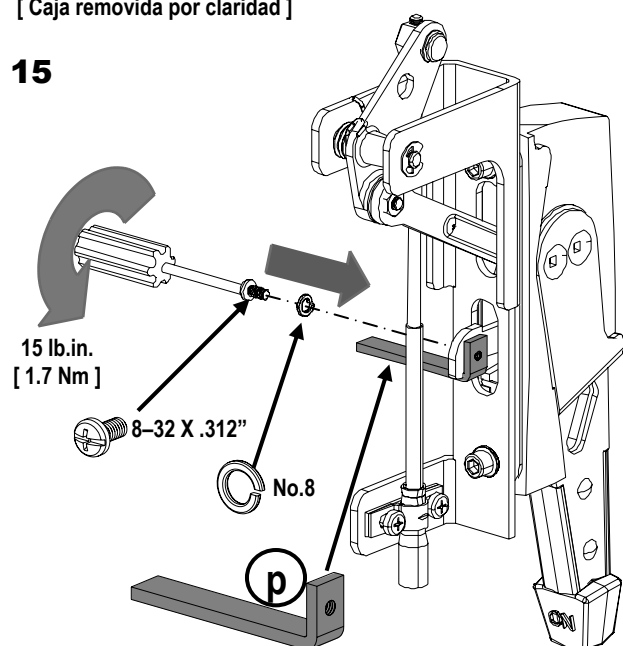

right hand side mounting
[Montaje de lado derecho]

Enclosure removed for clarity
[Caja removida por claridad]

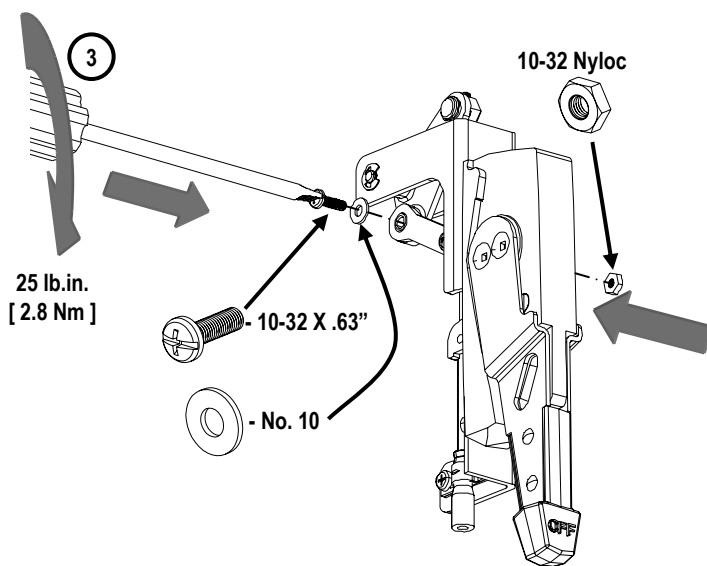

Enclosure removed for clarity
[Caja removida por claridad]

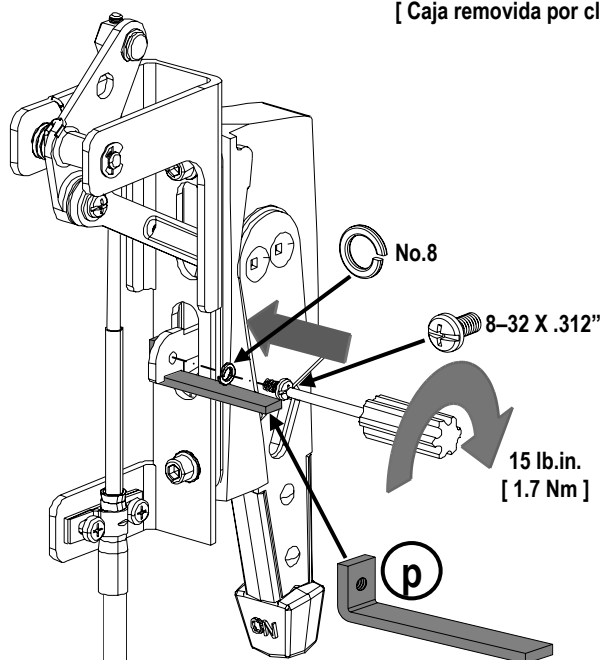

JG, LG, MG

16

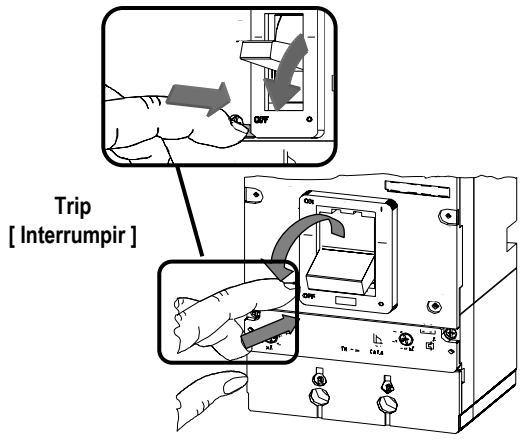

17

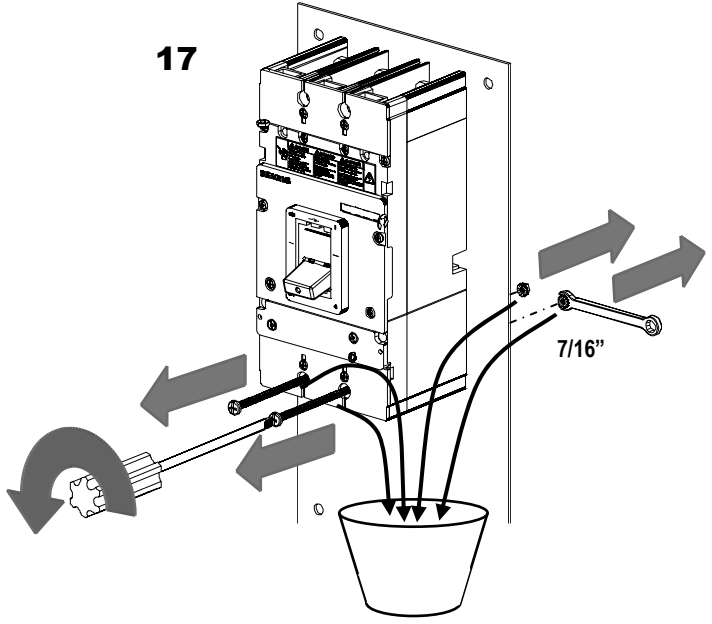

18

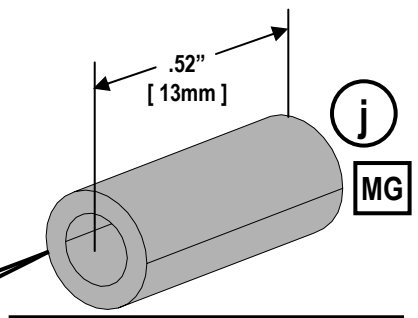
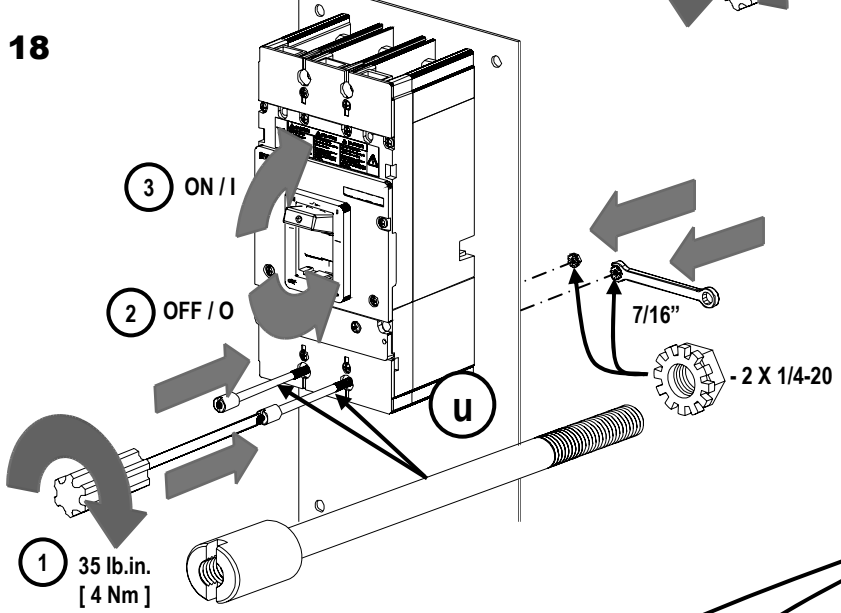

19

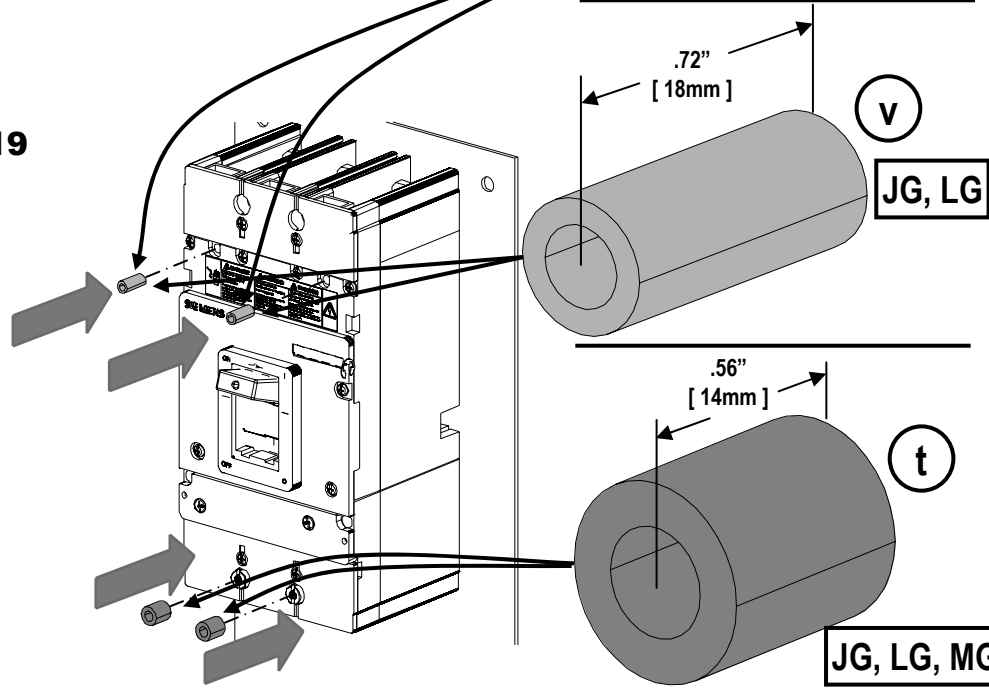



JG, LG, MG

	⚠ Danger	⚠ Peligro	⚠ Danger
	Hazardous Voltage. Will cause death or serious injury.	Tensión peligrosa. Puede causar la muerte o lesiones graves.	Tension dangereuse. Danger de mort ou risque de blessures graves.
	Turn off and lock out all power supplying this device before working on this device. Replace all covers before power supplying this device is turned on.	Desenergice totalmente antes de instalar o darle servicio. Reemplace todas las barreras y cubiertas antes de energizar el interruptor.	Couper l'alimentation de l'appareil et barrer avant de travailler. Remplacez tous les couverts avant que l'approvisionnement de pouvoir soit alimenté.

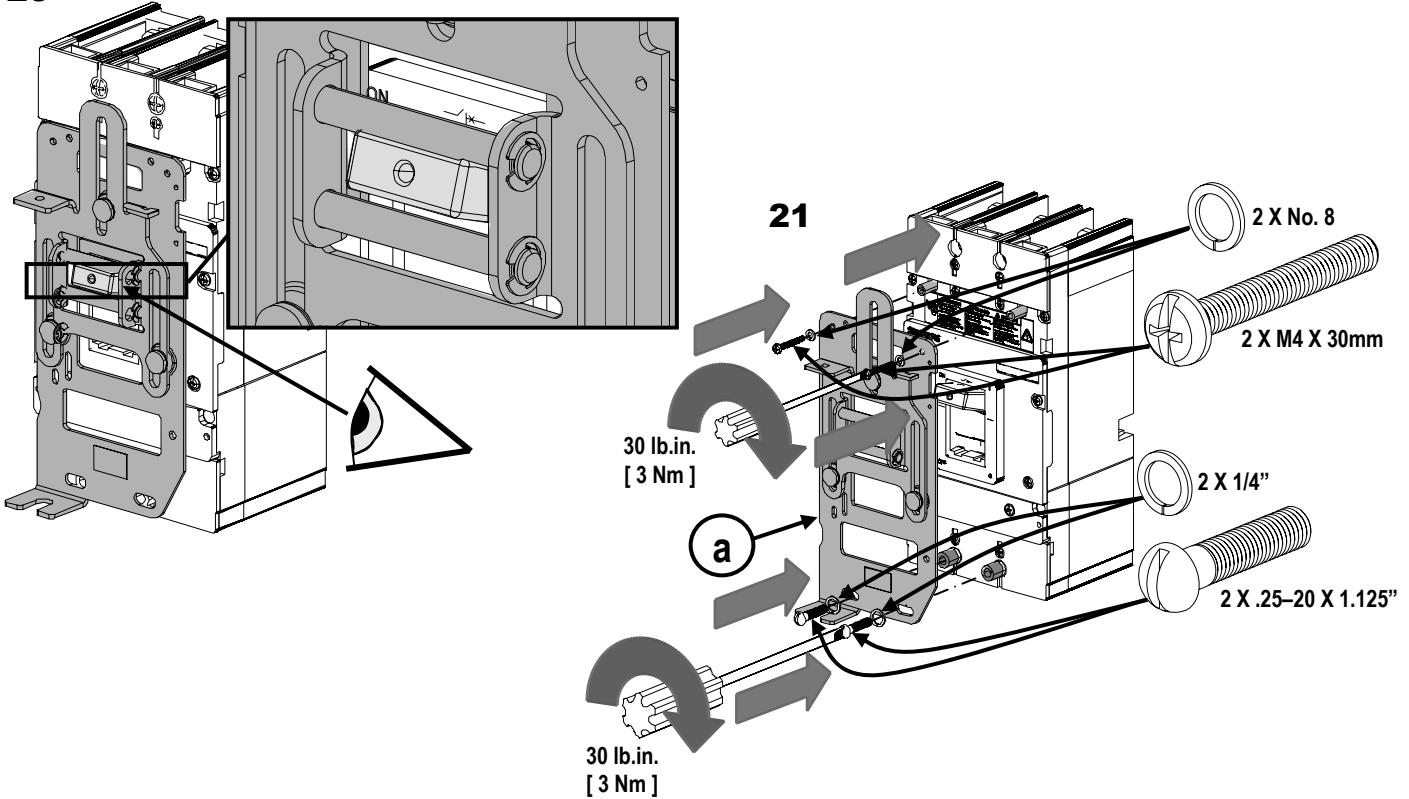
20



	⚠ WARNING	⚠ ADVERTENCIA	⚠ AVERTISSEMENT
	Hazardous Voltage. Can cause death or serious injury and Equipment Damage.	Tensión Peligrosa. Puede causar la muerte o lesiones graves y daños al equipo.	Tension dangereuse. Peut provoquer des blessures graves ou mortelles ou causer des dommages à l'équipement.
	Proper electrical clearances must be maintained	Las separaciones eléctricas adecuadas deben ser mantenidas.	Les dégagements électriques appropriés doivent être maintenus.

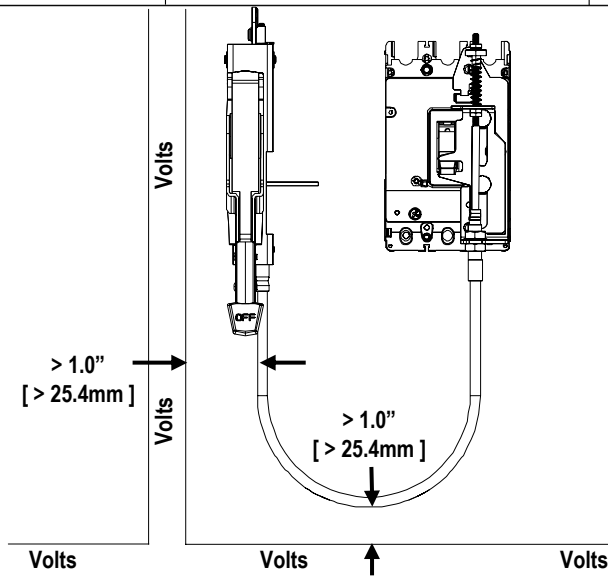

MFKL3R	3VL9400-3JM01
MFKM3R	3VL9600-3JM01
MFHM3R	3VL9600-3JP01
MFHM3RB	3VL9600-3JP11
MFHM3RSB	3VL9600-3JP61
MFHM3RS	3VL9600-3JP21
MFHM4X	3VL9600-3JP41

Ex: MFKL3R / 3VL9400-3JM01

22

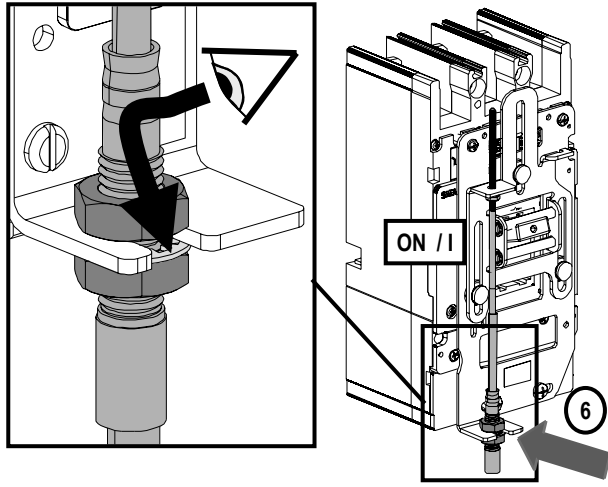
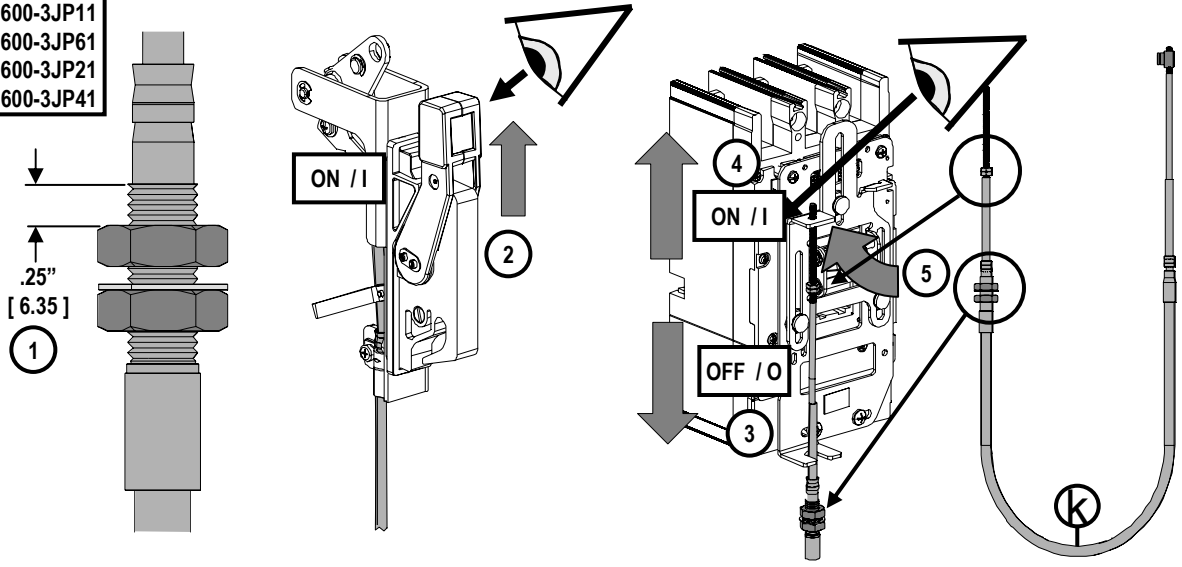

23

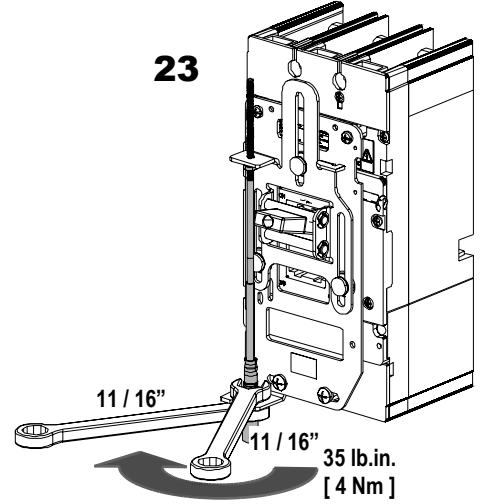

24

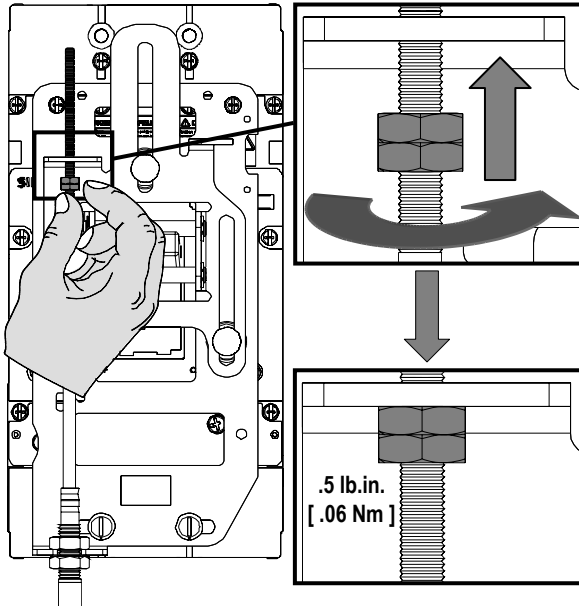

25

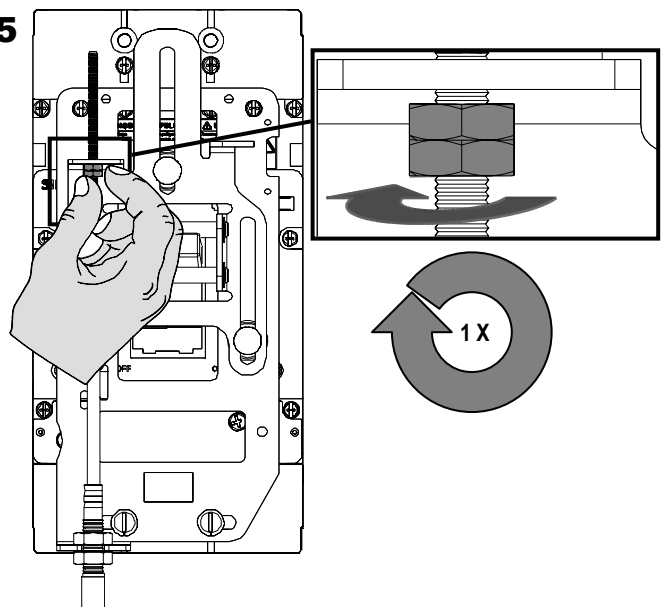



Danger

Hazardous Voltage.
Will cause death or serious injury.

Turn off and lock out all power supplying this device before working on this device.
Replace all covers before power supplying this device is turned on.

Peligro

Tensión peligrosa.
Puede causar la muerte o lesiones graves.

Desenergice totalmente antes de instalar o darle servicio.
Reemplace todas las barreras y cubiertas antes de energizar el interruptor.

Danger

Tension dangereuse.
Danger de mort ou risque de blessures graves.

Couper l'alimentation de l'appareil et barrer avant de travailler.
Remplacez tous les couverts avant que l'alimentation de l'appareil soit alimentée.

26

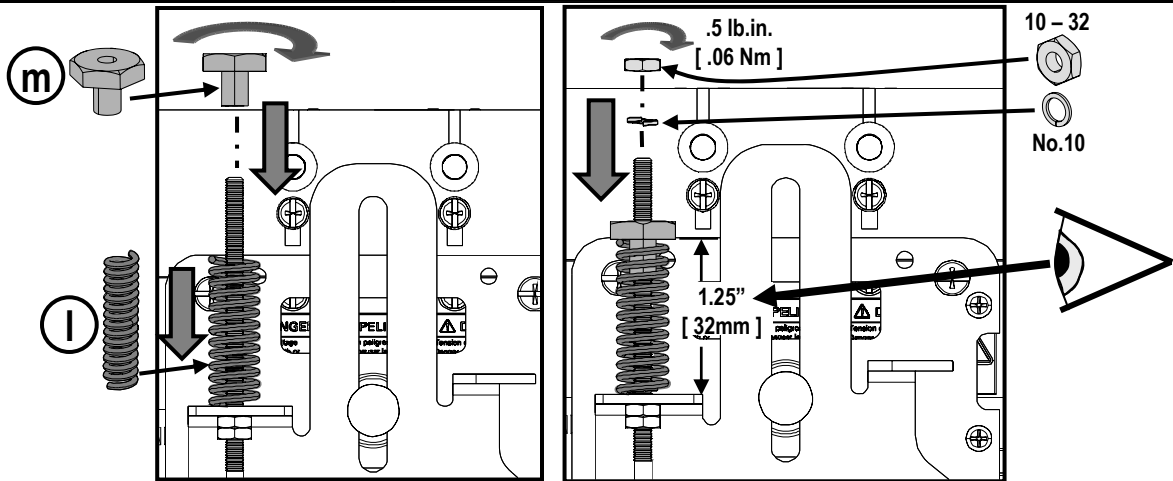

Test: ON / I – OFF / O
[Prueba: ON / I – OFF / O]

27

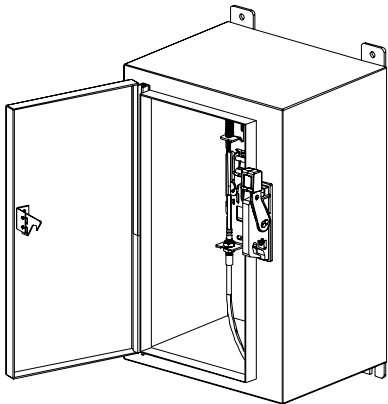

		Result [Resultado]		Go To Step [Ir Al Paso]
27a	ON / I → OFF / O	OFF / O	OK	27b
	ON / I	ON / I	OK	28
27b	OFF / O → ON / I	ON / I	OK	30
	OFF / O	OFF / O	OK	29

28

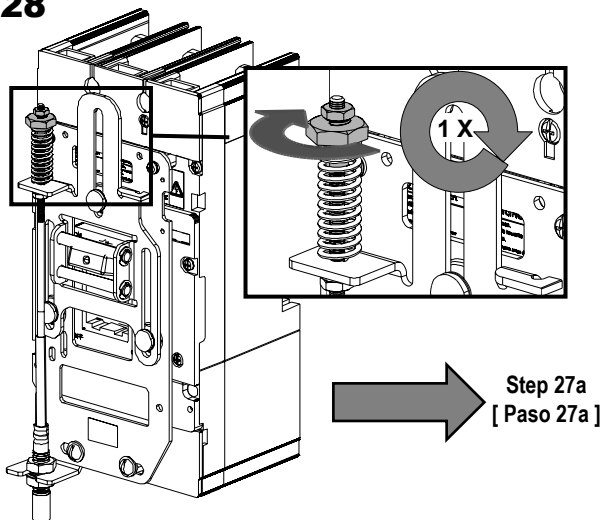

29

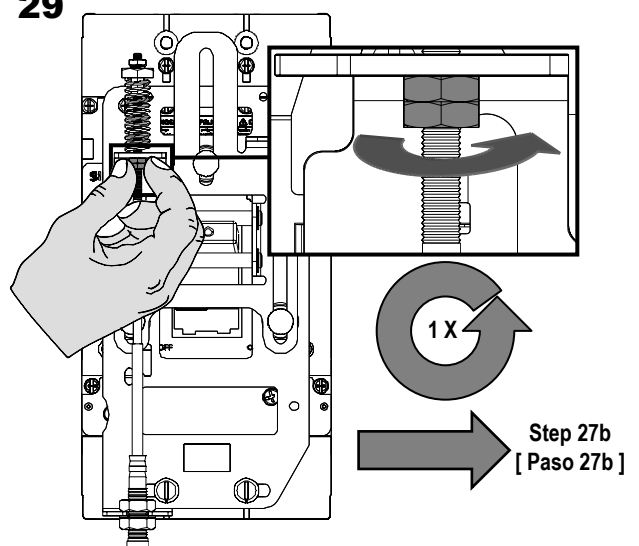

30

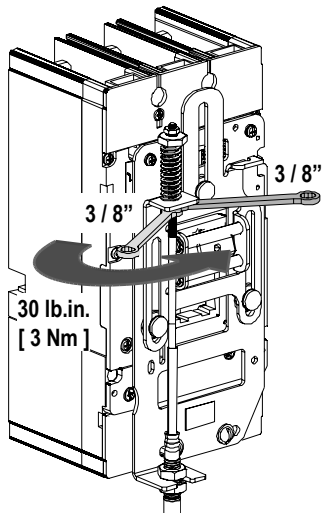

Test: Reset
[Prueba: Restablecer]

31

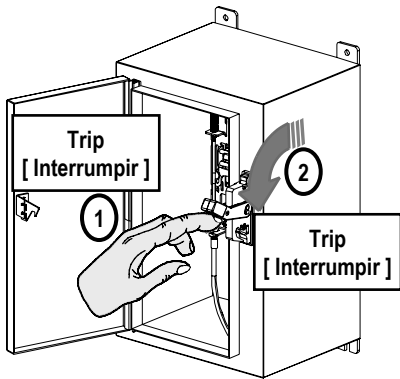

32

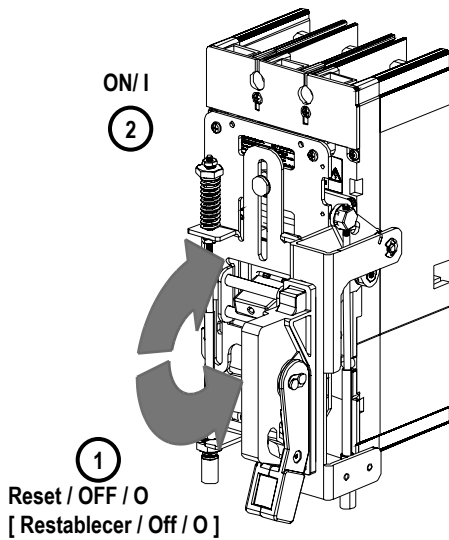

	Result [Resultado]	Go To Step [Ir Al Paso]		
			ON / I	OFF / O
32a			OK	34
			OK	33



⚠ Danger

Hazardous Voltage.

Will cause death or serious injury.

Turn off and lock out all power supplying this device before working on this device.

Replace all covers before power supplying this device is turned on.



⚠ Peligro

Tensión peligrosa.

Puede causar la muerte o lesiones graves.

Desenergice totalmente antes de instalar o darle servicio. Reemplace todas las barreras y cubiertas antes de energizar el interruptor.

⚠ Danger

Tension dangereuse.

Danger de mort ou risque de blessures graves.

Couper l'alimentation de l'appareil et barrer avant de travailler.

Remplacez tous les couverts avant que l'alimentation de pouvoir soit alimenté.

33

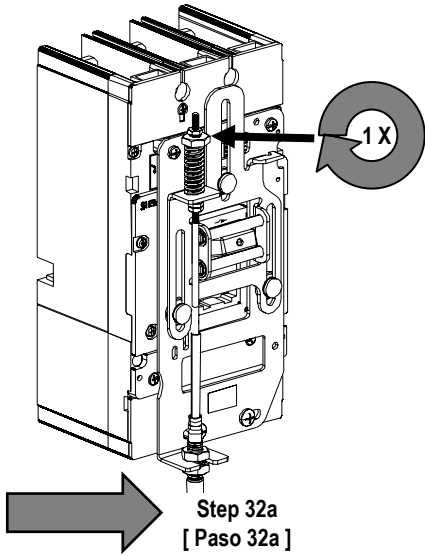

34

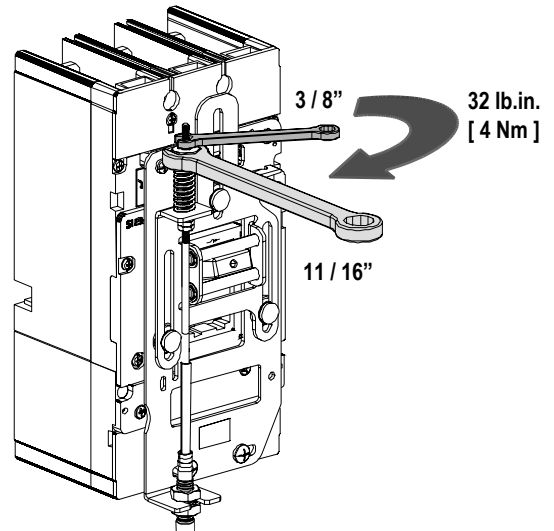

Test: Door Latch

[Prueba: Seguro de la Puerta]

35

		Result [Resultado]		Step [Paso]
		Open [Abierta]	Closed [Cerrados]	
<p>OFF / O → ON / I</p>	<p>5 lbf [22 N]</p>			37
				36

36

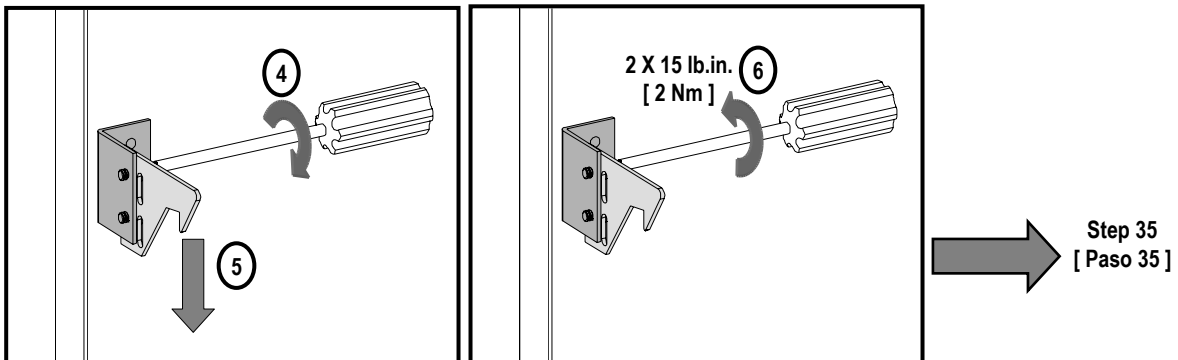



⚠ Danger

**Hazardous Voltage.
Will cause death or serious injury.**

Turn off and lock out all power supplying this device before working on this device.
Replace all covers before power supplying this device is turned on.

⚠ Peligro

**Tensión peligrosa.
Puede causar la muerte o lesiones graves.**

Desenergice totalmente antes de instalar o darle servicio.
Reemplace todas las barreras y cubiertas antes de energizar el interruptor.

⚠ Danger

**Tension dangereuse.
Danger de mort ou risque de blessures graves.**

Couper l'alimentation de l'appareil et barrer avant de travailler.
Remplacez tous les couverts avant que l'alimentation de pouvoir soit alimenté.

37

		Result [Resultado]		Step [Paso]
		 Open [Abierta]	 Closed [Cerrados]	
ON / I OFF / O	5 lbf [22 N]			38

38

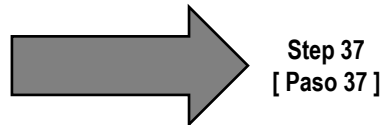
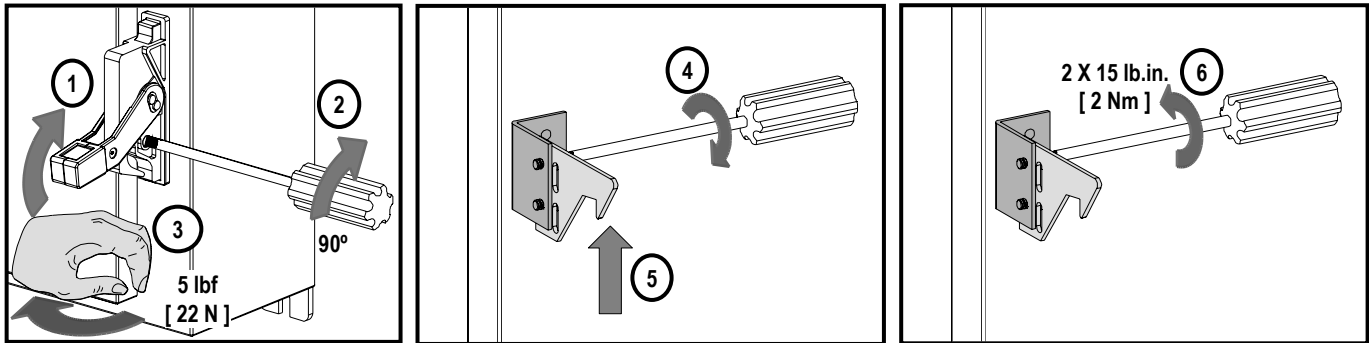

**Option:
[Opción:]**

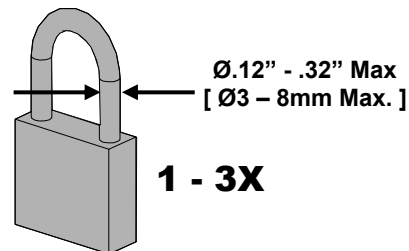
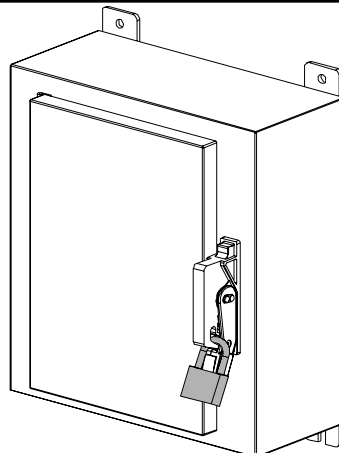

For Support in Europe refer to :

Bestell-Nr. / Order No.: 3ZX1012-0VL68-8BA1

Internet: www.siemens.de/lowvoltage/technical-assistance

GWA 4NEB 179 6907-10 DS 02

Technical Support:

Toll Free: 1-800-964-4114

Internet: www.sea.siemens.com

Subject to change without prior notice

Siemens Energy & Automation Inc. , Alpharetta, GA U.S.A.

16 / 16

© Siemens Energy & Automation Inc. 2006

806907A01