

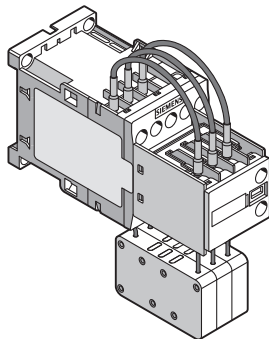

SIRIUS

3RT261.-1....
3RT262.-1....

DE	Kondensatorschütz S00 / S0 Originalbetriebsanleitung	ES	Contactor para condensadores S00 / S0 Instructivo original	TR	Kondansatör Kontaktörü' S00 / S0 Orijinal İşletme Kılavuzu
EN	Capacitor Switching Contactor S00 / S0 Original Operating Instructions	IT	Contattore per condensatori S00 / S0 Istruzioni operative originali	РУ	Контактор конденсатора S00 / S0 Оригинальное руководство по эксплуатации
FR	Contacteur pour condensateurs S00 / S0 Instructions de service originales	PT	Contactor do condensador S00 / S0 Instruções de Serviço Originais	中文	电容接触器 S00 / S0 原始操作说明



3RT261.-1....

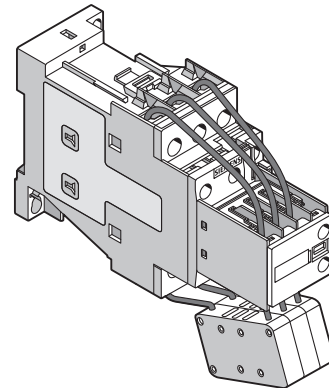

3RT262.-1....









SIEMENS AG	Telephone: +49 (911) 895-5900 (8° - 17° CET)
Technical Assistance	Fax: +49 (911) 895-5907
Breslauer Str. 5	E-mail: technical-assistance@siemens.com
D-90766 Fürth	Internet: www.siemens.com/sirius/technical-assistance



www.siemens.com/sirius/support
3ZX1012-0RT20-5AC1



DE		GEFAHR Gefährliche Spannung. Lebensgefahr oder schwere Verletzungsgefahr. Vor Beginn der Arbeiten Anlage und Gerät spannungsfrei schalten.
EN		DANGER Hazardous voltage. Will cause death or serious injury. Turn off and lock out all power supplying this device before working on this device.
FR		DANGER Tension dangereuse. Danger de mort ou risque de blessures graves. Mettre hors tension avant d'intervenir sur l'appareil.
ES		PELIGRO Tensión peligrosa. Puede causar la muerte o lesiones graves. Desconectar la alimentación eléctrica antes de trabajar en el equipo.
IT		PERICOLO Tensione pericolosa. Può provocare morte o lesioni gravi. Scollegare l'alimentazione prima di eseguire interventi sull'apparecchiatura.
PT		PERIGO Tensão perigosa. Perigo de morte ou ferimentos graves. Desligue a alimentação elétrica e proteja contra o religamento, antes de iniciar o trabalho no equipamento.
TR		TEHLİKE Tehlikeli gerilim. Ölüm tehlikesi veya ağır yaralanma tehlikesi. Çalışmalara başlamadan önce, sistemin ve cihazın gerilim beslemesini kapatınız.
PY		ОПАСНОСТЬ Опасное напряжение. Опасность для жизни или возможность тяжелых травм. Перед началом работ отключить подачу питания к установке и к устройству.
中文		危险 危险电压。可能导致生命危险或重伤危险。 操作设备时必须确保切断电源。

DE		VORSICHT Verletzungsgefahr. - Keine Handbetätigung durchführen - Keine Reparatur an ausgefallenen Geräten
EN		CAUTION Danger of personal injury. - Do not operate manually - Do not carry out repairs on faulty contactors
FR		PRUDENCE Risque de blessure. - Manœuvrer l'appareil uniquement par voie électrique - Remplacer les appareils défectueux (les appareils ne peuvent pas être réparés)
ES		PRECAUCIÓN Peligro de lesiones. - No maniobre con la mano el aparato - No repare los aparatos defectuosos
IT		CAUTELA Pericolo di lesioni. - Non eseguire nessun comando manuale - Non eseguire nessuna riparazione su apparecchi guasti
PT		CUIDADO Perigo de ferimentos. - Não efectuar activações manuais - Não efectuar reparações em aparelhos com anomalias
TR		DIKKAT Yaralanma tehlikesi. - Kontaktörü elle devreye sokmayın - Devre dışı kalan cihazlarda onarım yapmayın
PY		ВНИМАНИЕ Опасность травмирования. - Не включать вручную - Неисправные устройства не ремонтировать
中文		小心 受伤危险。 - 切勿用手操作 - 切勿维修故障设备

DE	ACHTUNG	<p>Gefahr von Sachschäden. Um eine Zerstörung des Geräts zu vermeiden, beachten Sie bitte folgende Hinweise:</p> <ul style="list-style-type: none"> - Keine Überschreitung der zulässigen Schalthäufigkeit - Kein Einschalten von geladenen Kondensatoren - Kein Schalten ohne die angeschlossenen Vorladewiderstände - Keine undefinierte oder gestörte Steuerspannung (z.B. bei Entnahme der Steuerspannung aus dem Hauptstromkreis ohne Steuertransformator) - Keine Kurzzeitunterbrechung der Steuerspannung und anschließender Einschaltung von noch nicht entladenen Kondensatoren - Keine Handbetätigung für Funktionstest - Keine Dicht-an-Dicht-Montage zulässig (erforderlicher seitlicher Mindestabstand ≥ 10 mm)
EN	NOTICE	<p>Danger of material damage. To prevent the contactors from being destroyed, please follow these instructions:</p> <ul style="list-style-type: none"> - Do not exceed the permissible number of switching operations - Do not close the contactors when the capacitors are loaded - Do not operate the contactors unless the precharging resistors are connected - Do not use any undefined or faulty control voltage (e.g. if control voltage is drawn from the main circuit without a control transformer) - After short-time interruptions of the control voltage, do not switch on capacitors that have not yet discharged - Do not operate manually for function test - Side-by-side mounting not permitted (required minimum lateral clearance ≥ 10 mm)
FR	IMPORTANT	<p>Risque de dommages matériels. Afin d'éviter des dommages matériels sur l'appareil, tenez compte des indications suivantes :</p> <ul style="list-style-type: none"> - Respecter la fréquence de manœuvre maximale - Manœuvrer uniquement des condensateurs vides - Manœuvre uniquement avec les résistances de pré-charge - Garantir une tension de commande fiable et sûre (par exemple pas de tension de commande prélevée sur le circuit principal sans transformateur de commande) - Veiller à ce que des condensateurs qui ne sont pas entièrement déchargés ne soient pas remis en circuit après une courte interruption de la tension de commande - Ne pas effectuer de test fonctionnel par manœuvre manuelle - Ne pas réaliser de montage juxtaposé (distance latérale minimale nécessaire ≥ 10 mm)
ES	ATENCIÓN	<p>Peligro de daños materiales. Para evitar la destrucción del aparato tenga en cuenta lo siguiente:</p> <ul style="list-style-type: none"> - No sobrepasar la frecuencia de maniobra permitida - No cerrar el contactor sobre condensadores cargados - No maniobrar si no están conectadas las resistencias limitadoras - No usar tensiones de control indefinidas o perturbadas (p. ej. si la tensión de control se toma del circuito principal sin intercalar un transformador al efecto) - Si se interrumpe brevemente la tensión de control, no cerrar a continuación el contactor que maniobra condensadores aún no descargados - No maniobre con la mano para pruebas funcionales - No se permite montar los contactores pegados a otros aparatos (distancia lateral mínima necesaria: ≥ 10 mm)
IT	ATTENZIONE	<p>Pericolo di danni materiali. Per evitare la distruzione dell'apparecchio, rispettare le seguenti avvertenze:</p> <ul style="list-style-type: none"> - Non superare la frequenza di manovra max. ammessa - Non inserire i condensatori carichi - Non eseguire nessuna manovra senza le resistenze di precarica collegate - Non impiegare tensioni di comando indefinite o disturbate (ad es. in caso di prelievo della tensione di comando dal circuito principale senza trasformatore di comando) - In caso di interruzioni temporanee della tensione di comando, non inserire successivamente i condensatori non ancora scarichi - Non eseguire nessun comando manuale per il test funzionale - Nessun montaggio affiancato consentito (distanza minima richiesta ≥ 10 mm)

PT	ATENÇÃO	<p>Perigo de danos materiais. Para evitar a destruição do aparelho, tenha em atenção as seguintes indicações:</p> <ul style="list-style-type: none"> - Não ultrapassar a frequência de comutação admissível - Não ligar condensadores carregados - Não operar sem as resistências de pré-carga ligadas - Não utilizar uma tensão de comando indefinida ou com interferências (por ex. quando a tensão de comando é extraída do circuito principal sem um transformador de comando) - Não efectuar interrupções breves da tensão de comando nem activar em seguida condensadores que ainda não estejam descarregados - Não efectuar activações manuais para o teste de funcionamento - A montagem justa não é permitida (distância lateral mínima necessária ≥ 10 mm)
TR	DIKKAT	<p>Maddi hasar tehlikesi. Cihazın hasar görmesinden/tahrip olmasından kaçınmak için aşağıdaki uyarıları lütfen dikkate alın:</p> <ul style="list-style-type: none"> - İzin verilen anahtarlama sıklığı aşılmamalıdır - Şarj edilmiş kondansatörler devreye sokulmamalıdır - Bağlı ön şarj dirençleri olmadan anahtarlama yapılmamalıdır - Tanımlanmamış veya arızalı kumanda gerilimi kullanılmamalıdır (örneğin kumanda geriliminin kumanda trafosuz ana devreden alınması) - Kumanda gerilimi kısa süreli olarak kesilmemeli ve ardından henüz deşarj edilmemiş kondansatörler devreye sokulmamalıdır - Çalışıp çalışmadığını test etmek için elle devreye sokulmamalıdır - Contadan contaya montaja izin verilmez (gerekli yan asgari mesafe ≥ 10 mm)
PY	ЗАМЕТКА	<p>Опасность материального ущерба. Во избежание повреждения устройства следуйте приведенным ниже указаниям:</p> <ul style="list-style-type: none"> - Не превышайте допустимую частоту коммутирования - Не включайте заряженные конденсаторы - Не включайте без подсоединенных предварительных сопротивлений - Не использовать неопределенное или сопровождаемое помехами напряжение управления (напр., при получении напряжения управления из силовой цепи без трансформатора управления) - Никаких кратковременных прерываний напряжения управления и последующего включения еще не разряженных конденсаторов - Не включать вручную для проверки функционирования - Монтаж без зазора недопустим (требуемый минимальный боковой зазор ≥ 10 мм)
中文	注意	<p>存在造成物资损失的危險 . 为了避免设备发生故障，请遵守下列注意事项：</p> <ul style="list-style-type: none"> - 切勿超过允许的开关次数 - 切勿接通已经加载的电容器 - 切勿在未连接预充电电阻的情况下开关 - 不得存在未经定义的控制电压或者故障电压（例如在没有控制变压器的情况下移除主电路中的控制电压） - 切勿短时断开未卸载电容器的控制电压并在之后重启 - 切勿手动操作进行功能测试 - 禁止采用密集式安装（侧面最小间距必须 ≥ 10 mm）

DE	Montage	ES	Montaje	TR	Montaj
EN	Assembly	IT	Montaggio	PT	Montaj
FR	Montage	PT	Montagem	中文	安装

3RT261.-1....

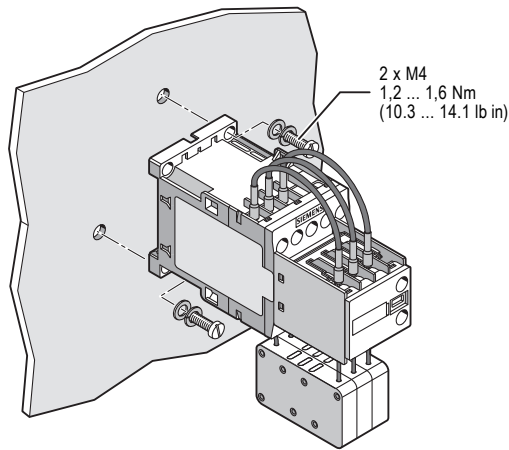
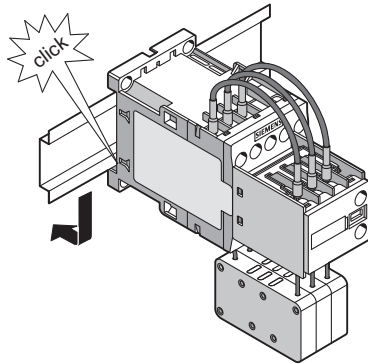

3ZX1012-0RT20-5AC1

3RT262.-1....

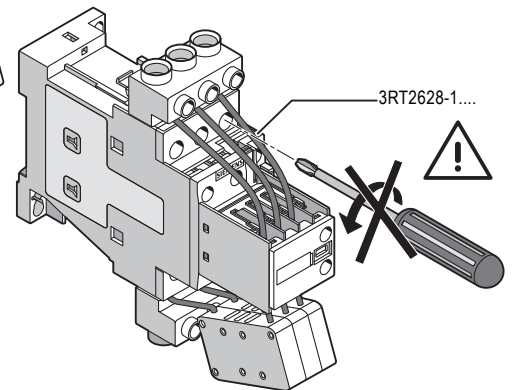
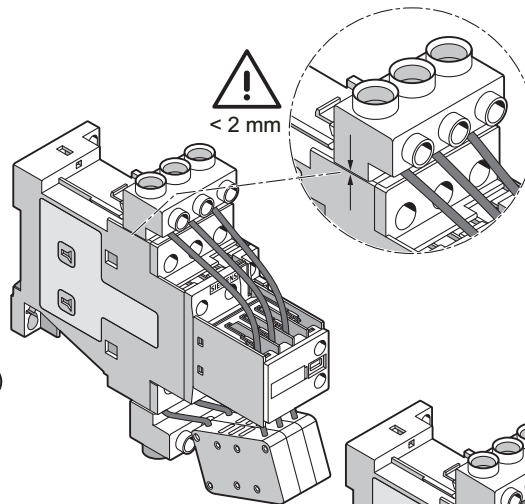
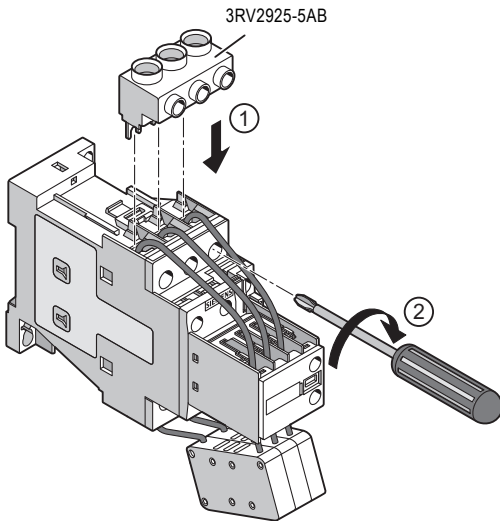
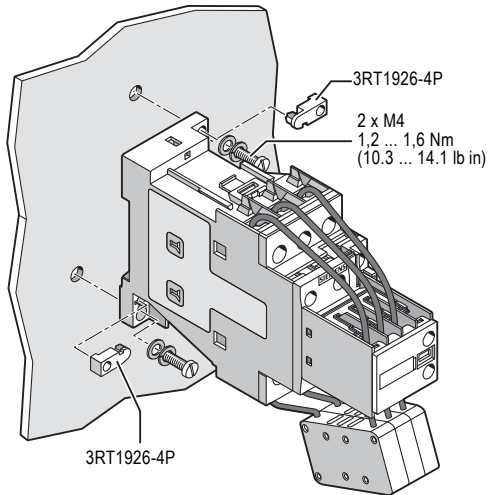
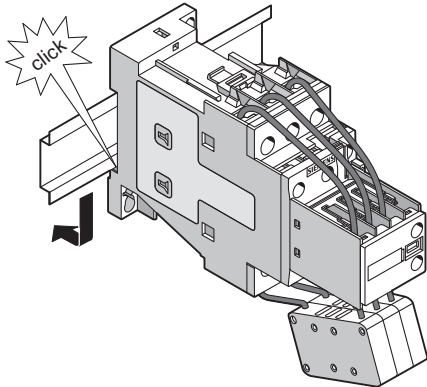

DE	Zubehör	ES	Accesorios	TR	Aksesuar
EN	Accessories	IT	Accessori	PY	Принадлежности
FR	Accessoires	PT	Acessórios	中文	附件
DE	Montage Überspannungsbegrenzer	ES	Montaje del limitador de sobretensiones	TR	Aşırı gerilim sınırlayıcı montajı
EN	Mounting of surge suppressors	IT	Montaggio del limitatore di sovratensione	PY	Монтаж ограничителя перенапряжения
FR	Montage du limiteur de surtension	PT	Montagem do limitador de sobretensão	中文	安装过电压限制器

3RT261.-1....



3ZX1012-0RT20-5AC1

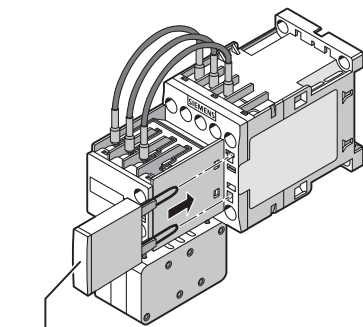

3RT2916-1...

DE	Anschließen	ES	Conexión	TR	Bağlantı
EN	Connect	IT	Collegamento	PY	Подсоединение
FR	Branchement	PT	Conexão	中文	连接

	A1/A2, NO/NC	S00	S0	
		L1 L2 L3 3RT261.-1	L1 L2 L3 3RT262.-1	3RT262.-1 + 3RV2925-5AB
	PZ 2: Ø (5 ... 6 mm) 0,8 ... 1,2 Nm (7 to 10.3 lb-in)	PZ 2: Ø (5 ... 6 mm) 0,8 ... 1,2 Nm (7 to 10.3 lb-in)	PZ 2: Ø (5 ... 6 mm) 2 ... 2,5 Nm (18 to 22 lb-in)	PZ 2: Ø (5 ... 6 mm) 3 ... 4 Nm (27 to 35.2 lb-in)
	2 x (0,5 ... 1,5) mm ² 2 x (0,75 ... 2,5) mm ² 2 x 4 mm ²	2 x (0,5 ... 1,5) mm ² 2 x (0,75 ... 2,5) mm ² 2 x 4 mm ²	2 x (1 ... 2,5) mm ² 2 x (2,5 ... 10) mm ²	1 x (2,5 ... 25) mm ²
	—	—	—	—
	2 x (0,5 ... 1,5) mm ² 2 x (0,75 ... 2,5) mm ²	2 x (0,5 ... 1,5) mm ² 2 x (0,75 ... 2,5) mm ²	2 x (1 ... 2,5) mm ² 2 x (2,5 ... 6) mm ² 1 x 10 mm ²	1 x (2,5 ... 16) mm ²
AWG	2 x (20 to 16) 2 x (18 to 14) 2 x 12	2 x (20 to 16) 2 x (18 to 14) 2 x 12	2 x (14 to 8)	1 x (10 to 4)

DE	Geräteschaltplan	ES	Esquema de conexiones	TR	Cihaz devre planı
EN	Device circuit diagram	IT	Schema delle connessioni	PY	Принципиальная схема
FR	Schéma des connexions	PT	Esquema elétrico do equipamento	中文	仪表接线图

3RT261.-.A..3

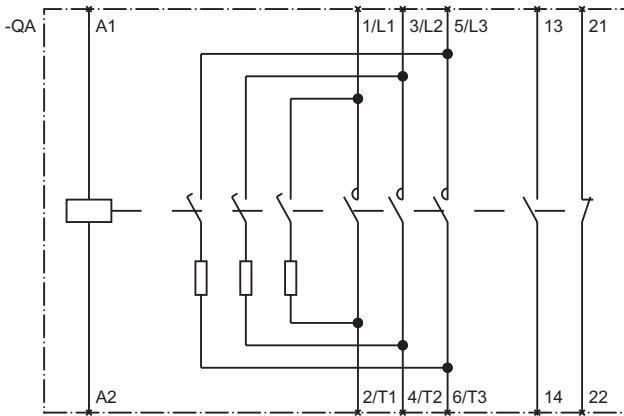

3RT261.-.A..5

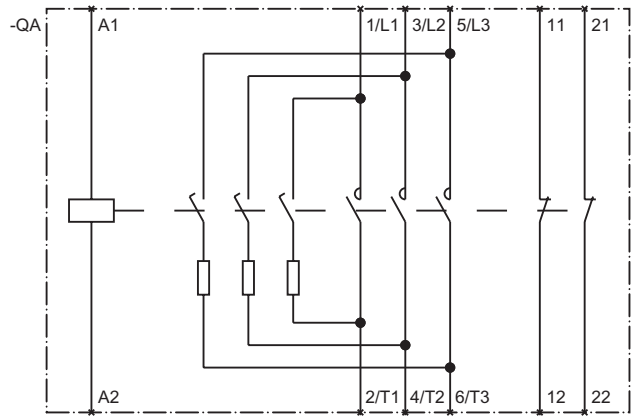

3RT262.-.A..5

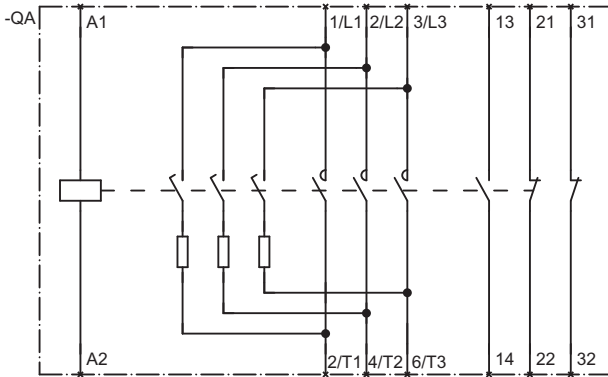

DE	Maßzeichnungen (Angaben in mm)	ES	Dibujos dimensionales (medidas en mm)	TR	Ölçü resimleri (Bilgiler mm olarak)
EN	Dimension drawings (all dimensions in mm)	IT	Disegni quotati (indicazioni in mm)	РУ	Размерные эскизы (Данные в мм)
FR	Ensembles (indications en mm)	PT	Desenhos cotados (dimensões em mm)	中文	尺寸图 (单位: mm)

3RT261.-1....

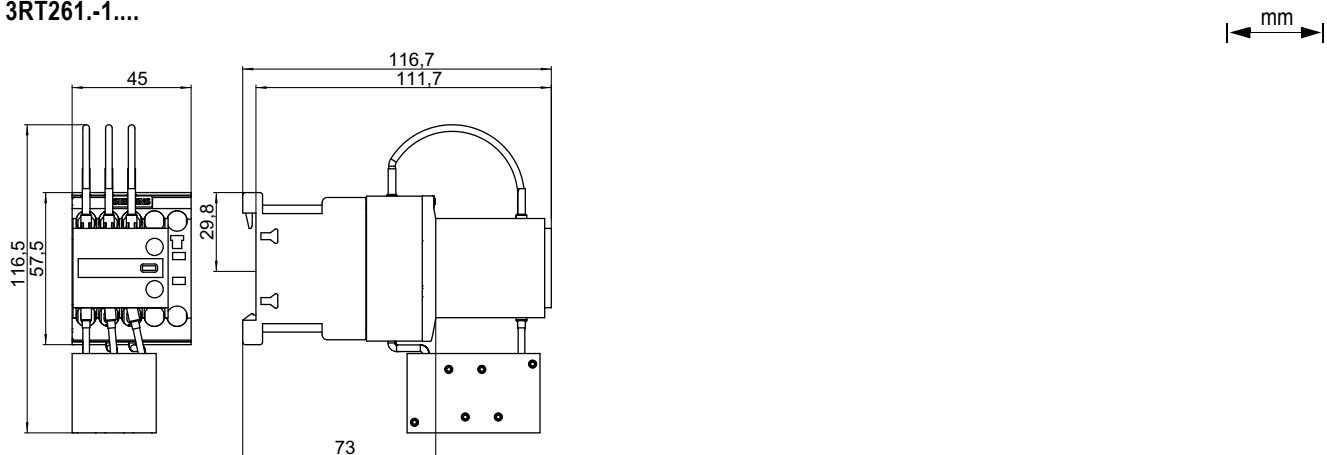

3RT2625-1A...

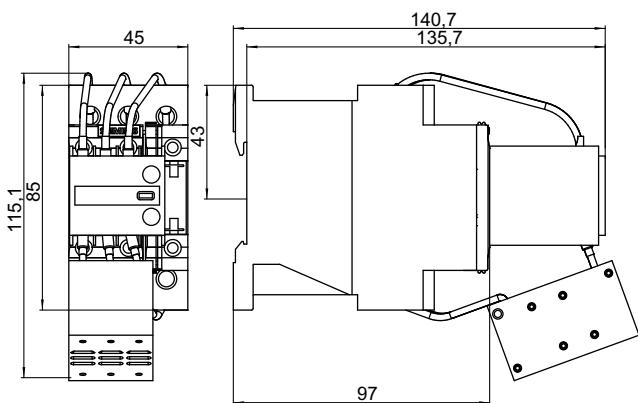

3RT2625-1B...

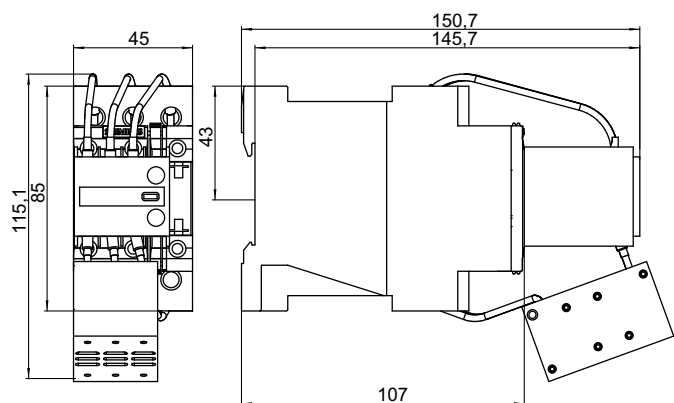

3RT2628-1A...

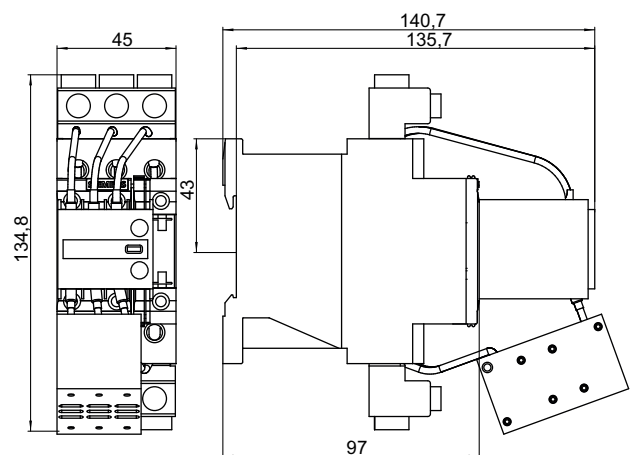

3RT2628-1B...

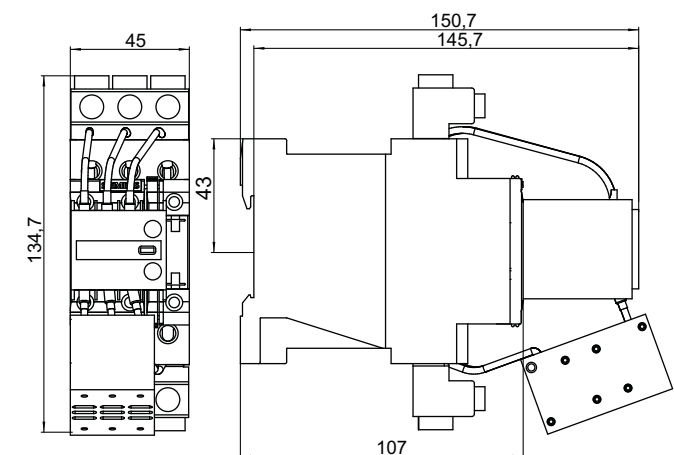

3RT261.

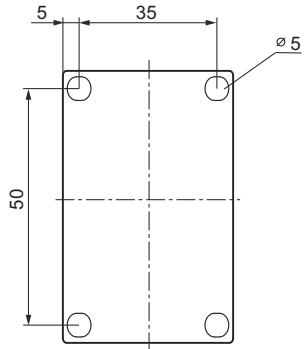

3RT262.

