

DE Leistungsschalter
EN Circuit-breaker
FR Disjoncteur

ES Interruptor automático / Guardamotor
IT Interruttore automatico
PT Disjuntor

TR Devre kesici anahtar
PY Силовой выключатель
中文 断路器



IEC/EN 60947
IEC/EN 60947-4-1



Betriebsanleitung DE
Operating Instructions EN
Instructions de service FR
Instructivo ES
Istruzioni operative IT
Instruções de Serviço PT
İşletme Kılavuzu TR
Руководство по эксплуатации PY
使用说明 中文

Technical Assistance:

Telephone: +49 (911) 895-5900 (8°° - 17°° CET)
Fax: +49 (911) 895-5907
E-mail: technical-assistance@siemens.com
Internet: www.siemens.com/sirius/technical-assistance

SIEMENS AG
Technical Assistance
Breslauer Str. 5
D-90766 Fürth

DE		GEFAHR	Gefährliche Spannung. Lebensgefahr oder schwere Verletzungsgefahr. Vor Beginn der Arbeiten Anlage und Gerät spannungsfrei schalten.
EN		DANGER	Hazardous voltage. Will cause death or serious injury. Turn off and lock out all power supplying this device before working on this device.
FR		DANGER	Tension dangereuse. Danger de mort ou risque de blessures graves. Mettre hors tension avant d'intervenir sur l'appareil.
ES		PELIGRO	Tensión peligrosa. Puede causar la muerte o lesiones graves. Desconectar la alimentación eléctrica antes de trabajar en el equipo.
IT		PERICOLO	Tensione pericolosa. Può provocare morte o lesioni gravi. Scollegare l'alimentazione prima di eseguire interventi sull'apparecchiatura.
PT		PERIGO	Tensão perigosa. Perigo de morte ou ferimentos graves. Desligue a alimentação elétrica e proteja contra o religamento, antes de iniciar o trabalho no equipamento.
TR		TEHLİKE	Tehlikeli gerilim. Ölüm tehlikesi veya ağır yaralanma tehlikesi. Çalışmalara başlamadan önce, sistemin ve cihazın gerilim beslemesini kapatınız.
PY		ОПАСНОСТЬ	Опасное напряжение. Опасность для жизни или возможность тяжелых травм. Перед началом работ отключить подачу питания к установке и к устройству.
中文		危险	危险电压。可能导致生命危险或重伤危险。 操作设备时必须确保切断电源。
DE		VORSICHT	Eine sichere Gerätefunktion ist nur mit zertifizierten Komponenten gewährleistet.
EN		CAUTION	Reliable functioning of the equipment is only ensured with certified components.
FR		PRUDENCE	La sécurité de fonctionnement de l'appareil n'est garantie qu'avec des composants certifiés.
ES		PRECAUCIÓN	El funcionamiento seguro del aparato sólo está garantizado con componentes certificados.
IT		CAUTELA	Il funzionamento sicuro dell'apparecchiatura è garantito soltanto con componenti certificati.
PT		CUIDADO	O funcionamento seguro do aparelho apenas pode ser garantido se forem utilizados os componentes certificados.
TR		ÖNEMLİ DİKKAT	Cihazın güvenli çalışması ancak sertifikalı bileşenler kullanılması halinde garanti edilebilir.
PY		ОСТОРОЖНО	Безопасность работы устройства гарантируется только при использовании сертифицированных компонентов.
中文		小心	只有使用经过认证的部件才能保证设备的正常运转。

Deutsch	English	Français
<p>Wichtiger Hinweis</p> <p>Die hier beschriebenen Produkte wurden entwickelt, um als Teil einer Gesamtanlage oder Maschine sicherheitsgerichtete Funktionen zu übernehmen. Ein komplettes sicherheitsgerichtetes System enthält in der Regel Sensoren, Auswerteeinheiten, Meldegeräte und Konzepte für sichere Abschaltungen. Es liegt im Verantwortungsbereich des Herstellers einer Anlage oder Maschine die korrekte Gesamt-funktion sicherzustellen. Die SIEMENS AG, ihre Niederlassungen und Beteiligungsgesellschaften (im Folgenden "SIEMENS") sind nicht in der Lage, alle Eigenschaften einer Gesamtanlage oder Maschine, die nicht durch SIEMENS konzipiert wurde, zu garantieren. SIEMENS übernimmt auch keine Haftung für Empfehlungen, die durch die nachfolgende Beschreibung gegeben bzw. impliziert werden. Auf Grund der nachfolgenden Beschreibung können keine neuen, über die allgemeinen SIEMENS-Lieferbedingungen hinaus gehenden, Garantie-, Gewährleistungs- oder Haftungsansprüche abgeleitet werden</p>	<p>Important note</p> <p>The products described herein are designed to be components of a customized machinery safety-oriented control system. A complete safety-oriented system may include safety sensors, evaluators, signaling units and concepts for ensuring safe switch-off. It is the responsibility of each manufacturer to ensure the correct overall functionality of its systems and machines. Siemens AG, its subsidiaries and affiliates (collectively "Siemens") are not in a position to guarantee all of the characteristics of a given system or product not designed by Siemens. Siemens accepts no liability for any recommendation that may be implied or stated herein. The warranty contained in the contract of sale by Siemens is the sole warranty of Siemens. Any statements contained herein do not create new warranties or modify existing ones</p>	<p>Remarque importante</p> <p>Les produits décrits dans cette notice ont été développés pour assurer des fonctions de sécurité en tant qu'éléments d'une installation complète ou d'une machine. Un système de sécurité complet comporte en règle générale des capteurs, des unités de traitement, des appareils de signalisation et des concepts de mise en sécurité. Il incombe au concepteur/constructeur de l'installation ou de la machine d'assurer le fonctionnement correct de l'ensemble. Siemens AG, ses succursales et ses participations (désignées ci-après par "Siemens") ne sont pas en mesure de garantir toutes les propriétés d'une installation complète ou d'une machine qui n'a pas été conçue par Siemens. Siemens dégage toute responsabilité pour les recommandations données dans la description ci-dessous ou qui peuvent en être déduites. La description ci-dessous ne peut pas être invoquée pour faire valoir des revendications au titre de la garantie ou de la responsabilité, qui dépasseraient les clauses des conditions générales de livraison de Siemens</p>
Español	Italiano	Português
<p>Nota importante</p> <p>Los productos aquí descritos están diseñados para ser usados como dispositivos de protección en instalaciones o máquinas. Por regla general, los sistemas de seguridad integran sensores, unidades de evaluación y señalización, así como conceptos para la desconexión segura. Es responsabilidad del fabricante de una instalación o máquina asegurar la correcta función del conjunto. La Siemens AG, sus filiales y/o sociedades participes (a continuación denominados "Siemens") no pueden garantizar que las instalaciones o máquinas no proyectados por parte de Siemens ofrezcan las características deseadas. No se podrá presentar reclamación alguna ante la empresa Siemens por los daños que se desprendan de las recomendaciones que incluyen o implican las siguientes descripciones. Las siguientes descripciones no implican otros derechos de garantía o reclamación nuevos ni ampliados respecto a las condiciones de entrega y suministro generales de la empresa Siemens</p>	<p>Nota importante</p> <p>I prodotti qui descritti sono stati concepiti per svolgere funzioni rilevanti per la sicurezza in interi impianti. Un sistema di sicurezza completo prevede normalmente sensori, dispositivi di segnalazione, apparecchiature e unità di valutazione e dispositivi per disinserzioni sicure. È compito del costruttore di macchine garantire il funzionamento sicuro dell'impianto o della macchina. La Siemens AG, le sue filiali e consociate (qui di seguito "Siemens") non sono in grado di garantire tutte le caratteristiche di un impianto o una macchina non ideati da Siemens. Siemens declina ogni responsabilità per raccomandazioni contenute nella presente descrizione. Non è possibile, in nome della presente documentazione, arrogare diritti di garanzia e/o responsabilità che vadano oltre quanto contenuto nelle condizioni generali di vendita e fornitura</p>	<p>Observação importante</p> <p>Os produtos aqui descritos foram concebidos para assumir como uma parte de uma unidade total ou de uma máquina, funções relacionadas com a segurança. Em geral, um sistema completo orientado para a segurança, contém sensores, unidades de interpretação, aparelhos sinalizadores e conceitos para circuitos de desconexão seguros. A responsabilidade pela garantia de um correto funcionamento geral recai sobre o fabricante de uma unidade ou máquina. A Siemens AG, suas filiais e sociedades de participação financeira (seguidamente designadas "Siemens") não estão em condições de garantir todas as características de uma unidade completa ou máquina não concebida pela Siemens. A Siemens não assume a responsabilidade por recomendações implicadas ou fornecidas pela seguinte descrição. Com base na descrição que se segue não podem ser interpretados novos direitos de garantia, qualidade de garantia ou indenizações, que vão para além das condições gerais de fornecimento da Siemens</p>
Türkçe	Русский	中文
<p>Önemli bilgi</p> <p>Burada açıklanan ürünler, komple bir tesisin ya da makinenin bir bölümü olarak, emniyete yönelik fonksiyonları üstlenmek üzere üretilmişlerdir. Komple bir emniyet sistemi, genel olarak, emniyetli biçimde devre kapatmak amacıyla sensör, değerlendirme birimleri, sinyal aletleri ve konseptler içerir. Bir tesis ya da makinenin komple eksiksiz işleminin sağlanması, üreticisinin sorumluluk alanına dahildir. Siemens AG, şubeleri ve ortaklıkları, (aşağıda "Siemens" olarak adı geçecektir), Siemens tarafından tasarımı yapılmamış bir komple tesisin ya da makinenin tüm özelliklerini garanti etmek durumunda değildir. Siemens, aşağıdaki açıklamalarda bulunan tavsiyeler için de herhangi bir sorumluluk üstlenmez. Aşağıdaki açıklamalara dayanılarak, yeni ve Siemens teslimat koşullarının dışında kalan garanti ya da mesuliyet taleplerinde bulunulamaz</p>	<p>Важное указание</p> <p>Описанные здесь изделия разработаны в качестве составной целой установки или машины для выполнения защитно-предохранительных функций. Полная система обеспечения безопасности содержит, как правило, датчики, устройства обработки данных, сигнальные приборы и концепции надежного отключения. Обязанностью изготовителя установки или машины является обеспечение правильности выполнения их общих функций. Компания Siemens AG, её филиалы и акционерные компании (в последующем "Siemens") не в состоянии гарантировать все характеристики всей установки или машины, не спроектированных компанией Siemens. Компания Siemens также не несет ответственности за рекомендации, которые приводятся или включены в последующее описание. Последующее описание не может служить основой для появления новых требований к гарантии, поручительству и ответственности, выходящих за рамки всеобщих условий поставки компании Siemens</p>	<p>重要提示</p> <p>这里所描述的产品作为成套机械设备的一部分用以确保其安全性。一个完整的安全开关系统通常包括传感器、分析单元、信号器以及用以安全切换的组件。保证设备或者机器正常发挥所有功能,是其制造商应负的责任。Siemens AG 及其分支机构和控股公司(以下简称"Siemens")无法对非 Siemens 所设计的整套设备或者机器的性能提供保证。Siemens 也不对后述说明所提出或者暗示的建议承担责任。不得以后述说明为根据,派生出超过 Siemens 一般供货条件范围的产品保修、产品保证或者责任赔偿要求</p>

DIN EN 60715

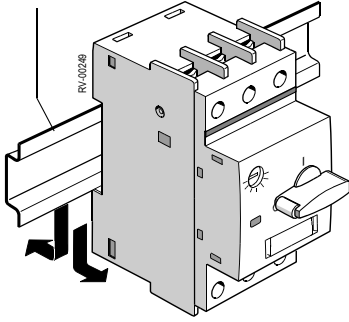

3RV2928-0B
 Bestell-Nr. = 10 Stück
 Order No. = 10 pieces
 N° de référence = 10 pièc.
 Ref. = 10 piezas
 N. di ordinaz. = 10 pez.
 N.º de enc. = 10 peças
 Sipariş numarası = 10 tane
 номер заказа = 10 штук
 订单号 = 10 件

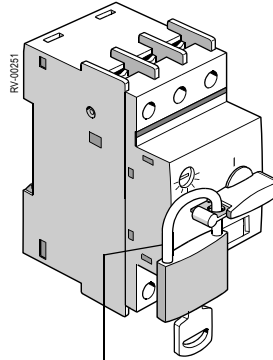

3RB1908-0P
 Bestell-Nr. = 10 Stück
 Order No. = 10 pieces
 N° de référence = 10 pièc.
 Ref. = 10 piezas
 N. di ordinaz. = 10 pez.
 N.º de enc. = 10 peças
 Sipariş numarası = 10 tane
 номер заказа = 10 штук
 订单号 = 10 件

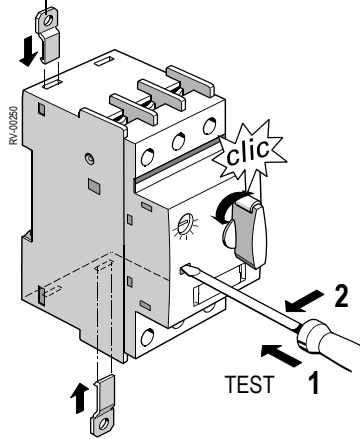

Ø 3,5 ... 4,5 mm

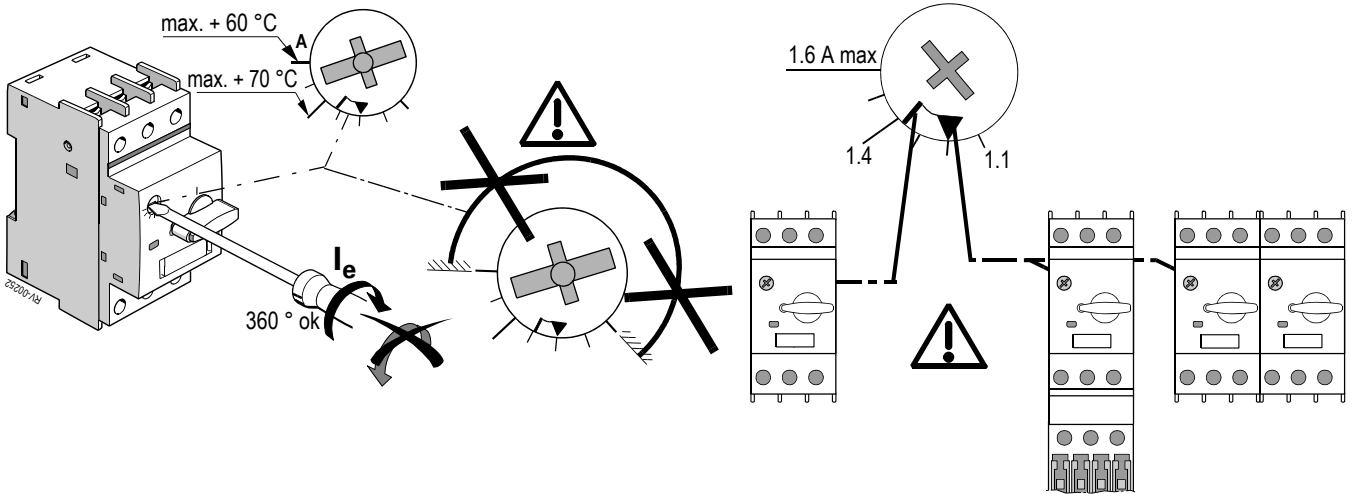
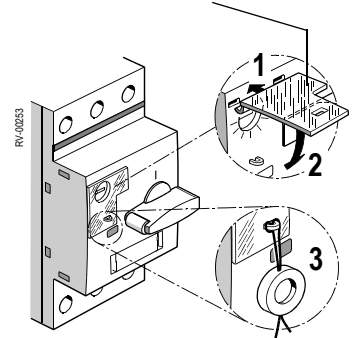

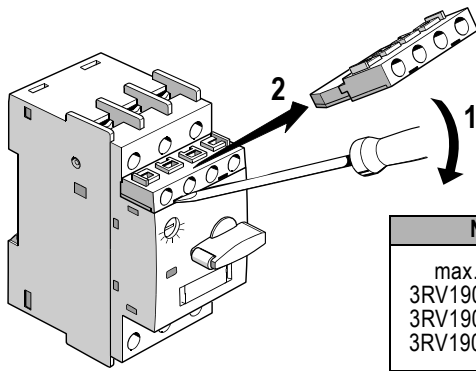
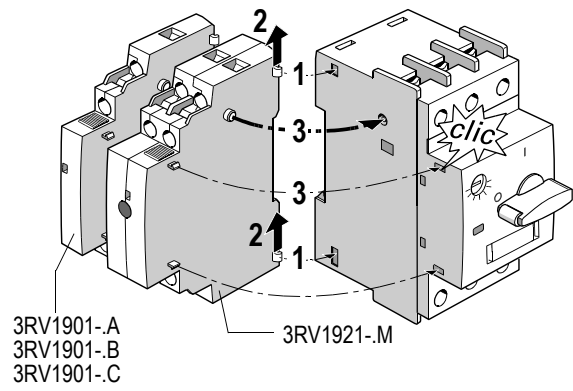
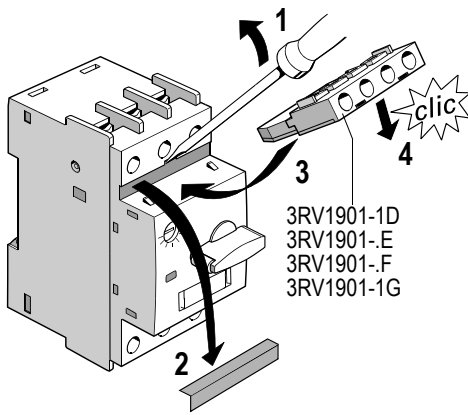

NC/NO: max. Stck. / pc.		
max.1: 3RV1901-A 3RV1901-B 3RV1901-C	+	max.1: 3RV1901-1D 3RV1901-E 3RV1901-F 3RV1901-1G
max.1: 3RV1901-1J		—

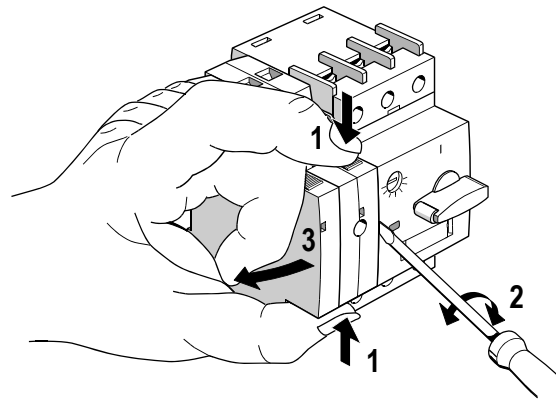

3RV19.2-1A..
3RV19.2-1C..
3RV19.2-1D..

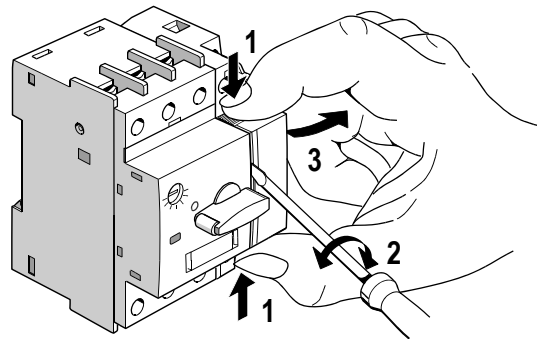
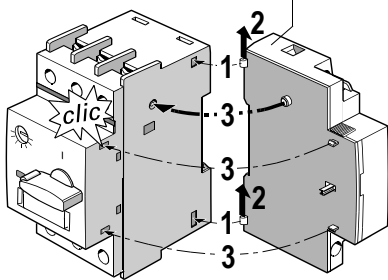

Test: 3RV19.2-1A..., 3RV19.2-1C..

Volt = 0 %

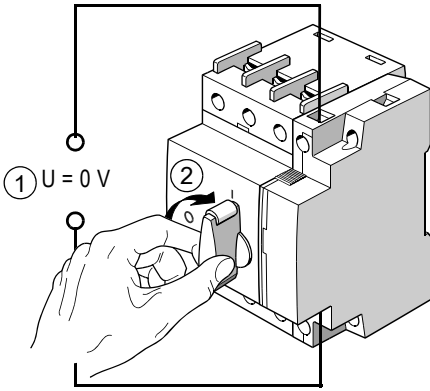

Volt = 0 %

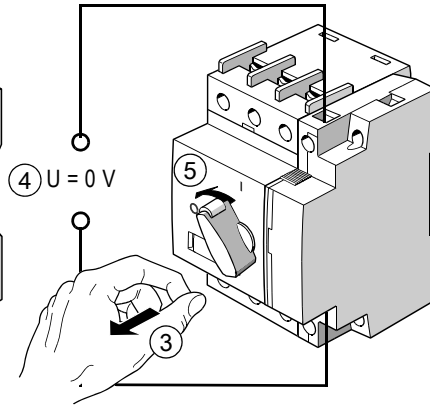

TRIPPED =

ON =



Technical Assistance

Volt = 100 %

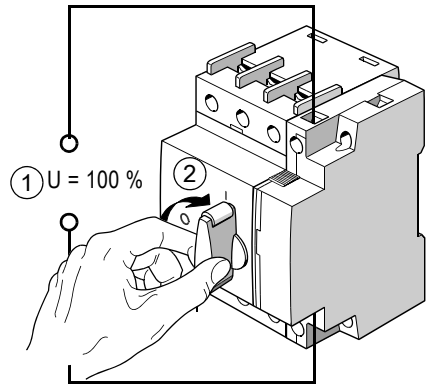

Volt = 0 %

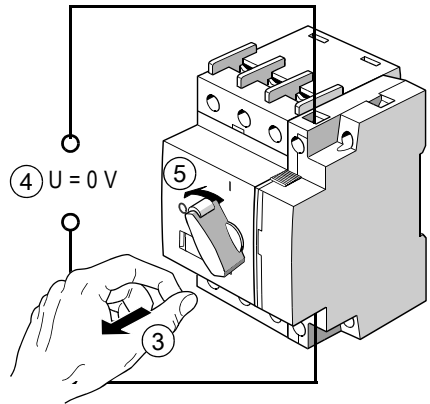



TRIPPED =

ON =



Technical Assistance

⚠️ WARNUNG	⚠️ DANGER	⚠️ DANGER
 <p>Gefährliche Spannung. Lebensgefahr oder schwere Verletzungsgefahr Nach einer Kurzschlussauslösung kann die Funktion des Unterspannungsauslöser beeinträchtigt sein. Prüfen Sie nach einer Kurzschlussauslösung (TRIPPED) die korrekte Montage des Unterspannungsauslöser und führen Sie den Funktionstest für 3RV1902-1A..., 3RV1902-1C... erneut aus.</p>	<p>Hazardous voltage. Will cause death or serious injury. After a short-circuit release, the function of the undervoltage release may be limited. After a short-circuit release (TRIPPED), please check that the undervoltage release has been installed properly and carry out a function test for the 3RV1902-1A..., 3RV1902-1C... again.</p>	<p>Tension électrique. Danger de mort ou risque de blessures graves. La fonction du déclencheur à minimum de tension peut être entravée après un déclenchement de court-circuit. Après un déclenchement de court-circuit (TRIPPED), vérifiez le montage correct du déclencheur à minimum de tension et effectuez de nouveau le test de fonctionnement pour le 3RV1902-1A..., 3RV1902-1C... .</p>
⚠️ PELIGRO	⚠️ PERICOLO	⚠️ PERIGO
 <p>Tensión peligrosa. Puede causar la muerte o lesiones graves. Tras un disparo por cortocircuito puede verse perjudicada la funcionalidad del disparador de mínima tensión. Tras un disparo por cortocircuito (TRIPPED), compruebe que el disparador de mínima tensión esté instalado correctamente y lleve a cabo nuevamente la prueba de funcionamiento del 3RV1902-1A..., 3RV1902-1C... .</p>	<p>Tensione pericolosa. Può provocare morte o lesioni gravi. Dopo uno sgancio per cortocircuito il funzionamento dello sganciatore di minima tensione può essere compromesso. Dopo uno sgancio per cortocircuito (TRIPPED) verificare il corretto montaggio dello sganciatore di minima tensione e ripetere il test di funzionamento per 3RV1902-1A..., 3RV1902-1C... .</p>	<p>Tensão perigosa. Perigo de morte ou ferimentos graves. Após um disparo por curto-circuito a função do disparador de subtensão pode estar prejudicada. Após um disparo por curto-circuito (TRIPPED) verifique a montagem correta do disparador de subtensão e execute novamente o teste funcional para 3RV1902-1A..., 3RV1902-1C... .</p>
⚠️ TEHLİKE	⚠️ ОПАСНО	⚠️ 危險
 <p>Tehlikeli gerilim. Ölüm tehlikesi veya ağır yaralanma tehlikesi. Kısa devre rölesinin açılmasından sonra alçak gerilim açtırma bobininin fonksiyonu olumsuz etkilenmiş olabilir. Kısa devre rölesinin açılmasından sonra (TRIPPED) alçak gerilim açtırma bobininin doğru monte edilip edilmediğini kontrol ediniz ve 3RV1902-1A..., 3RV1902-1C... için yeniden fonksiyon testi yapınız.</p>	<p>Опасное напряжение. Опасность для жизни или возможность тяжелых травм. В случае короткого замыкания возможно нарушение функций расцепителя минимального напряжения. При коротком замыкании (TRIPPED) проверьте правильность монтажа расцепителя минимального напряжения и заново выполните функциональную проверку для 3RV1902-1A..., 3RV1902-1C... .</p>	<p>危險电压。可能导致生命危险或重伤危险。 在发生短路脱扣之后欠电压脱扣器的功能可能会受到不良影响。因此在发生了短路脱扣 (TRIPPED) 之后要检查欠电压脱扣器的安装是否正确并对 3RV1902-1A..., 3RV1902-1C... 重新进行功能测试。</p>

Test: 3RV1902-1D..

Volt = 0 %

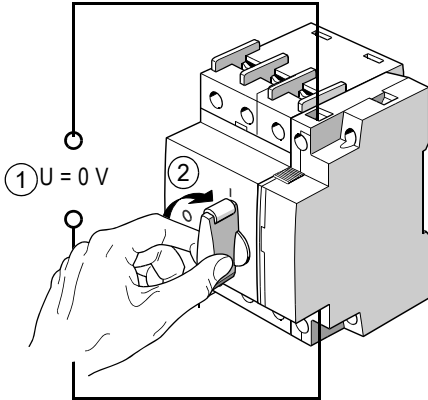

Volt = 100 %

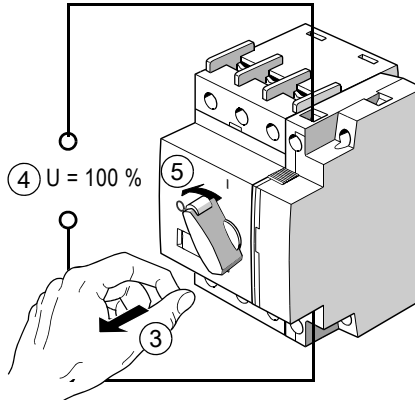

① U = 0 V

④ U = 100 %

TRIPPED =

ON =



Technical Assistance

3RV1121-....

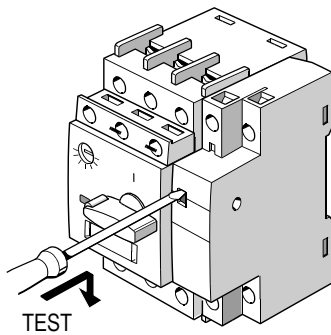



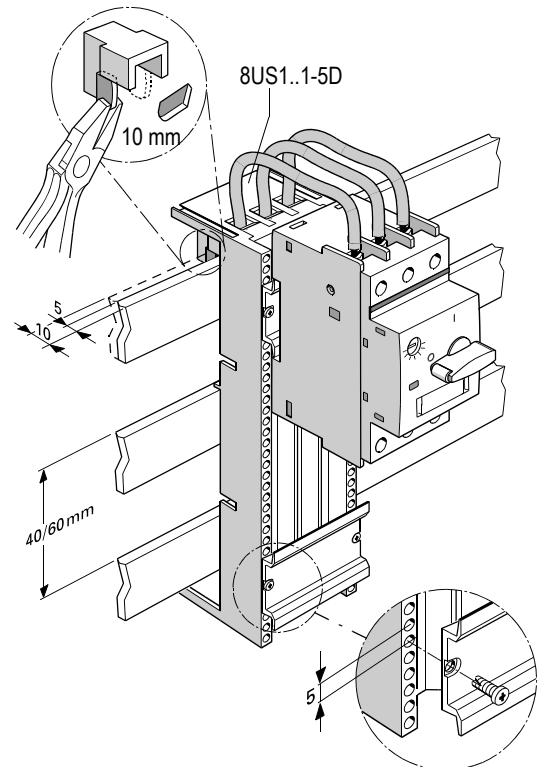
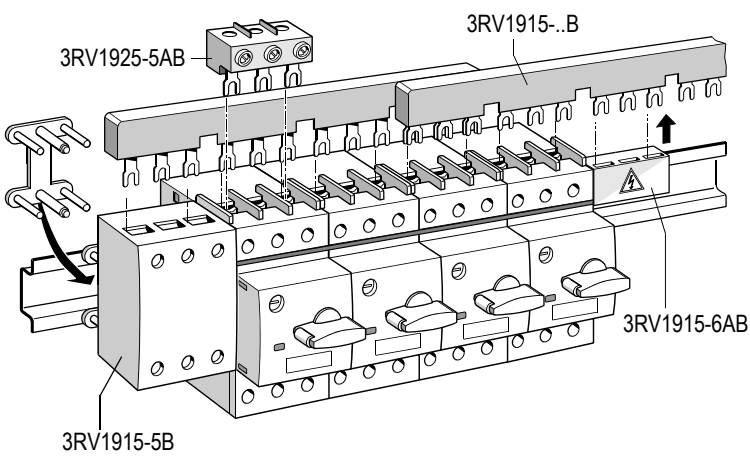
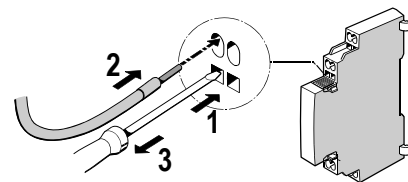

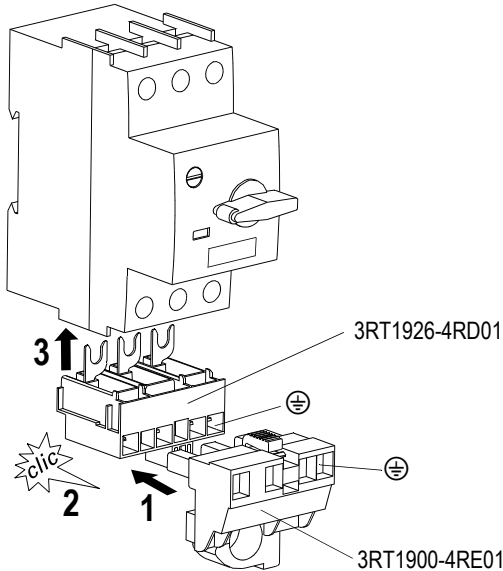
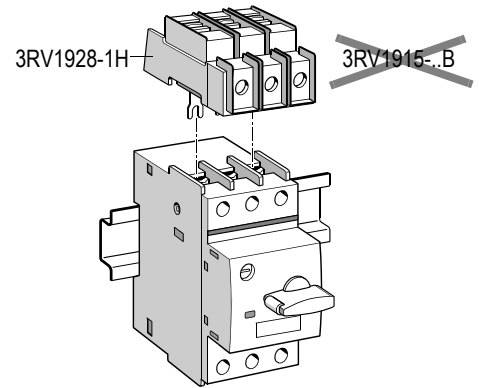
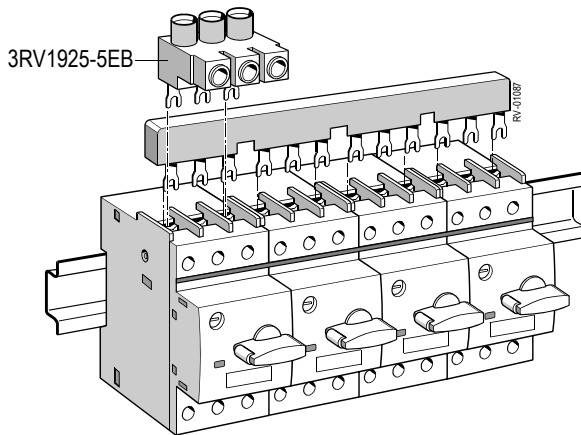

3RV1901-2.



UL: Self-Protected
Combination Controller Type E

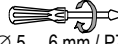

3RV1.2 + 3RT1926-4RD01	
DE	Am Ende der Lebensdauer gemeinsam wechseln
EN	Change together at end of service life
FR	A changer ensemble au terme de la durée de vie
ES	Al fin de la vida útil, cambiar de forma conjunta
IT	Sostituire insieme al termine della durata del dispositivo
PT	Ao final da vida útil, trocar em conjunto
TR	Ömrü bittiğinde beraber değiştiriniz
PY	В конце срока службы совместно заменить
中文	在寿命结束时一起更换

	L1 L2 L3 T1 T2 T3	D1, D2, C1, C2, NO/NC		3RV1925-5AB 3RV1925-5EB	3RV1915-5B	3RV1928-1H		
		3RV19..-1.	3RV19..-2.					
 Ø 5 ... 6 mm / PZ2	2 ... 2,5 Nm 18 to 22 lb·in	0,8 ... 1,2 Nm 7 to 10.3 lb·in	—	2 ... 4 Nm 17.6 to 35.2 lb·in	2 ... 4 Nm 17.6 to 35.2 lb·in	2,5 ... 3 Nm 22 to 26.5 lb·in		
	2 x 1 ... 2,5 mm ² 2 x 2,5 ... 6 mm ²	2 x 0,5 ... 1,5 mm ² 2 x 0,75 ... 2,5 mm ²	2 x 0,25 ... 2,5 mm ²	2,5 ... 25 mm ²	6 ... 25 mm ²	1 ... 10 mm ²	1 ... 10 mm ²	max. 10 + max. 10 mm ²
	2 x 1 ... 2,5 mm ² 2 x 2,5 ... 6 mm ² max. 1 x 10 mm ²	2 x 0,5 ... 1,5 mm ² 2 x 0,75 ... 2,5 mm ²	2 x 0,25 ... 2,5 mm ²	2,5 ... 25 mm ²	6 ... 25 mm ²	2,5 ... 25 mm ²	1,5 ... 25 mm ²	max. 10 + max. 25 mm ²
	2 x 1 ... 2,5 mm ² 2 x 2,5 ... 6 mm ² max. 1 x 10 mm ²	2 x 0,5 ... 2,5 mm ²	2 x 0,25 ... 1,5 mm ²	2,5 ... 16 mm ²	4 ... 16 mm ²	1 ... 16 mm ²	1 ... 16 mm ²	max. 10 + max. 10 mm ² max. 6 + max. 16 mm ²
AWG	2 x 14 to 10	2 x 18 to 14	2 x 24 to 14	12 to 4	10 to 4	14 to 3	16 to 3	max. 6 + max. 3

3RV102/142
3RV132

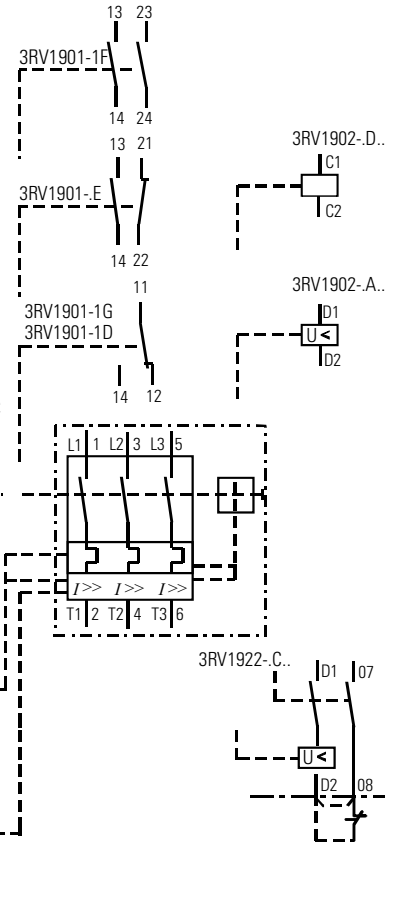

3RV1121-....

max. 10 A

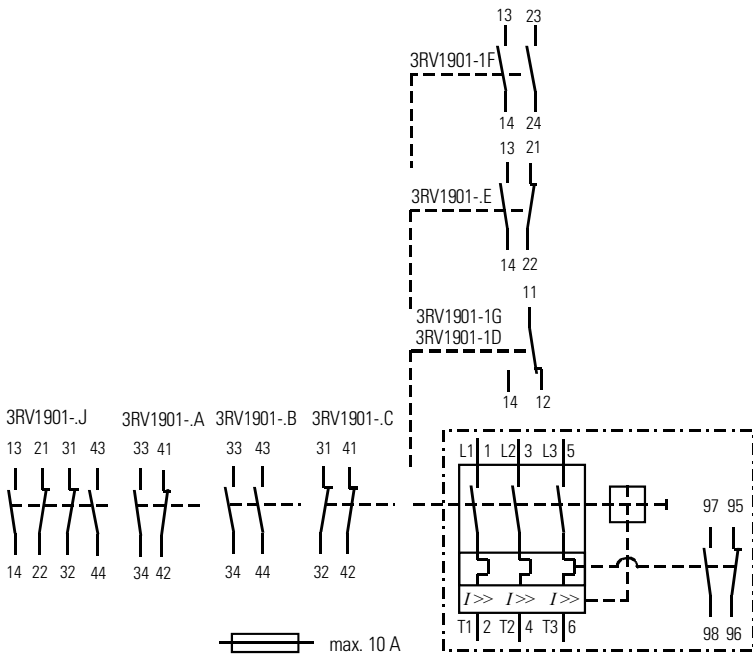

max. 10 A

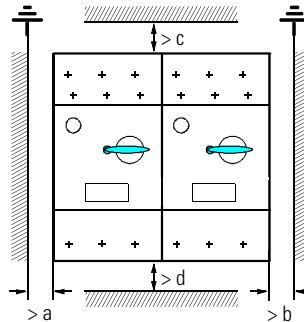
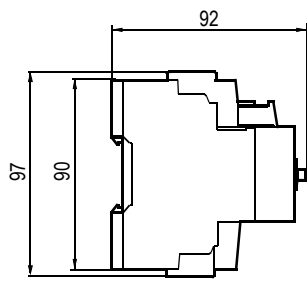
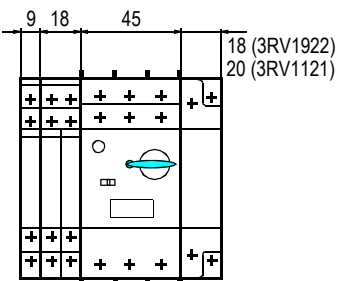

U _e (V)	a	b	c	d
240	9	9	30	30
400	9	9	30	30
440	9	9	30	30
500	9	9	30	30
690	30	30	50	50