

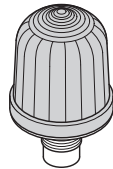

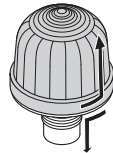

- Ⓓ Anschluss **ausschließlich** durch ausgebildete Elektro-Fachkräfte.
- ⒼⒸ Electrical connection is to be made by trained electrical specialists **only**.
- Ⓕ Le branchement doit **uniquement** être effectué par des professionnels.
- Ⓘ Il collegamento deve essere eseguito **solo** da elettricisti specializzati.
- Ⓔ La conexión **sólo** debe ser realizada por electricistas debidamente formados.
- ⒻⒿ A ligação deve ser feita **exclusivamente** por profissional eléctrico especializado.
- ⒼⒾ De aansluiting mag **enkel** gebeuren door erkende vakmensen.
- ⒸⒿ Připojení smí **provádět** pouze kvalifikovaný personál.
- ⒶⒻ Podłączenie **wyłącznie** przez specjalistów-elektryków.
- ⒻⒿ Liittäminen kuuluu **ainoastaan** koulutettujen sähköalan ammattilaisten tehtäviin.
- ⒶⒶⒾ Подключение проводится только специалистом-электриком.
- ⒻⒿ Bağlantı **sadece** eğitimli elektrik teknisyenleri tarafından yapılmalıdır.
- ⒸⒶⒶ 布线需由专业电工执行



206 x00 00	12 – 48 V \approx , \leq 5 W
207 x00 75	24 V \approx , 45 mA, I ₀ < 500 mA
207 x00 67	115 V \sim , 25 mA, I ₀ < 500 mA
207 x00 68	230 V \sim , 25 mA, I ₀ < 500 mA
208 x00 55	24 V \approx , 100 mA, \sim 0.75 Hz
208 x00 67	115 V \sim , 50/60 Hz 25 mA, \sim 0.75 Hz
208 x00 68	230 V \sim , 50/60 Hz 30 mA, \sim 0.75 Hz
216 x00 00	12 – 48 V \approx , \leq 7 W
	BA 15 d
956 x00 75	24 V \approx , 45 mA
	BA 15 d, \leq 42 mm (1.65 ") (206: \leq 5 W)
955 840 34	12 V
955 840 35	24 V
955 840 32	30 V
	BA 15 d, \leq 52 mm (2.05 ") 7 W
955 015 34	12 V
955 015 35	24 V



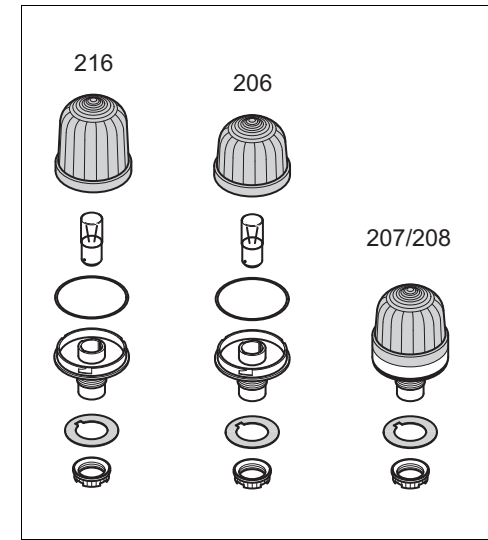

1

1a -206, 216
1b -207, 208

1a

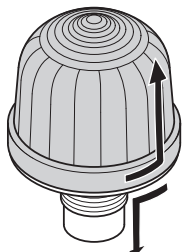

1b

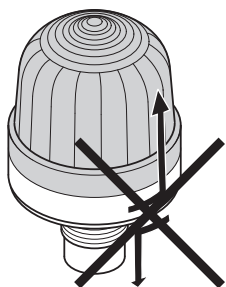

3

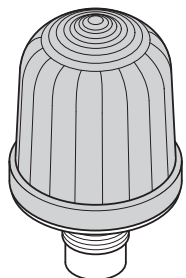

6,3 mm
0.25"



4

206, 216

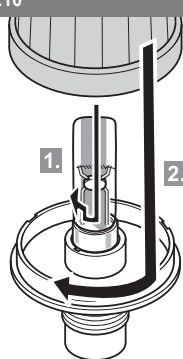

206, 216

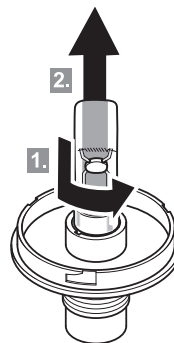

2

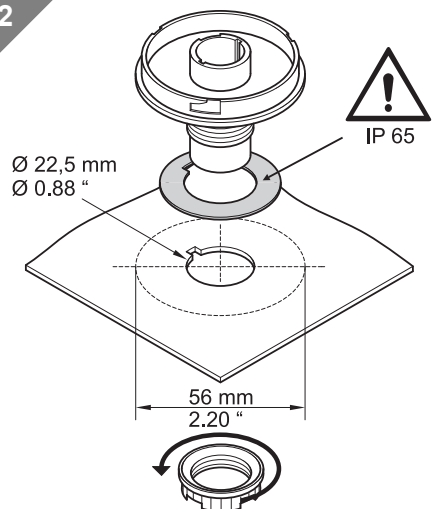

310.206.001.0312

© D