

- (D) Anschluss **ausschließlich** durch ausgebildete Elektro-Fachkräfte.
- (GB) Electrical connection is to be made by trained electrical specialists **only**.
- (F) Le branchement doit **uniquement** être effectué par des professionnels.
- (I) Il collegamento deve essere eseguito **solo** da elettricisti specializzati.
- (E) La conexión **sólo** debe ser realizada por electricistas debidamente formados.
- (PT) A ligação deve ser feita **exclusivamente** por profissional eléctrico especializado.
- (NL) De aansluiting mag **enkel** gebeuren door erkende vakmensen.
- (CZ) Připojení smí **provádět** pouze kvalifikovaný personál.
- (PL) Podłączenie **wyłącznie** przez specjalistów-elektryków.
- (FI) Liittäminen kuuluu **ainoastaan** koulutettujen sähköalan ammattilaisten tehtäviin.
- (RUS) Подключение проводится только специалистом-электриком.
- (TR) Bağlantı **sadece** eğitimli elektrik teknisyenleri tarafından yapılmalıdır.
- (CN) 布线需由专业电工执行

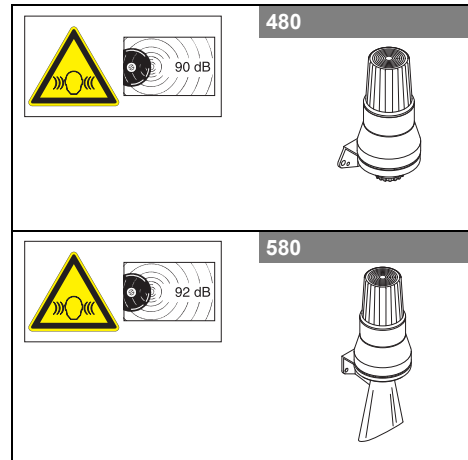
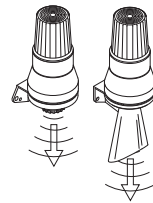
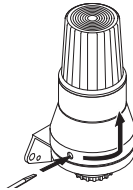

480 x52 54	90 dB, 12 V=, 610 mA
480 x52 55	90 dB, 24 V=, 320 mA
480 x52 66	90 dB, 48 V=, 170 mA
480 x52 68	90 dB, 230 V~, 50 mA
580 x52 54	92 dB, 12 V=, 610 mA
580 x52 55	92 dB, 24 V=, 320 mA
580 x52 65	92 dB, 24 V~, 320 mA
580 x52 56	92 dB, 48 V=, 220 mA
580 x52 67	92 dB, 115 V~, 75 mA
580 x52 68	92 dB, 230 V~, 50 mA

 BA15 d, ≤ 7 W

955 015 34	12 V=
955 015 35	24 V=
955 015 36	48 V=
955 015 37	115 V=
955 015 38	230 V=



**1**  
1a - 480  
1b - 580

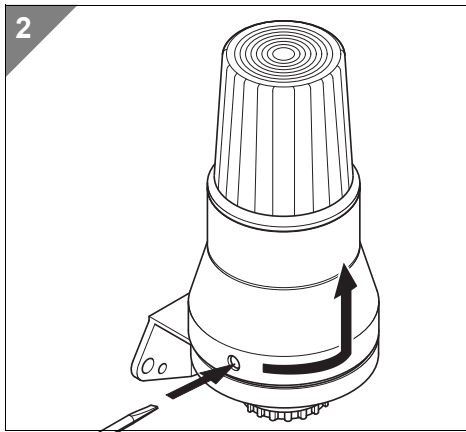
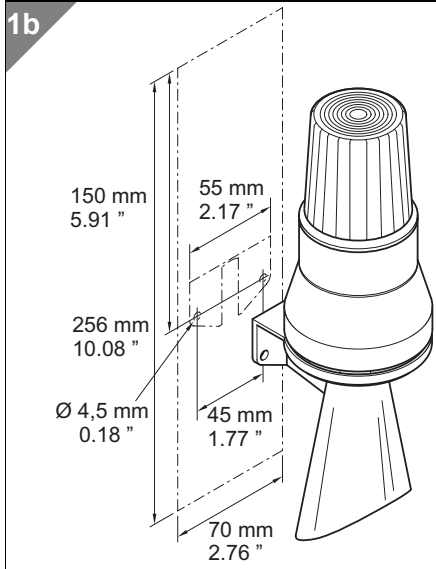
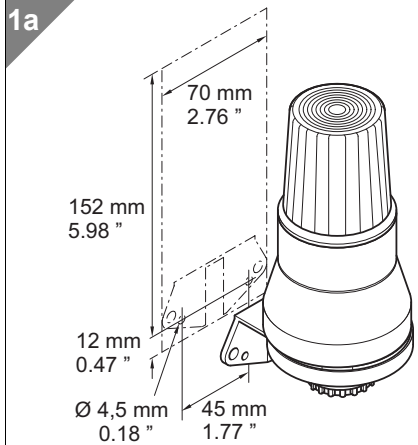

**3**  
3a - 480  
3b - 580

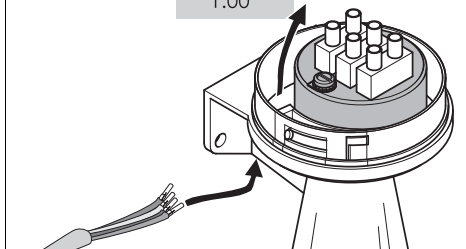
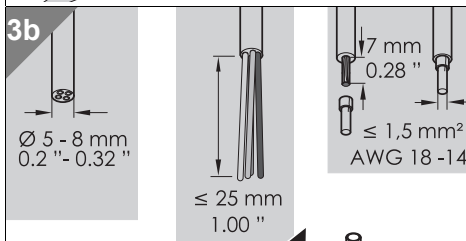
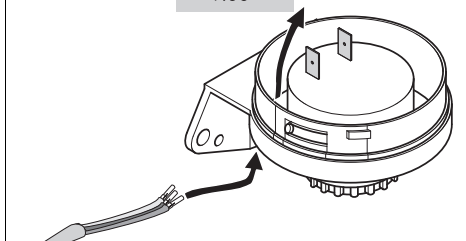
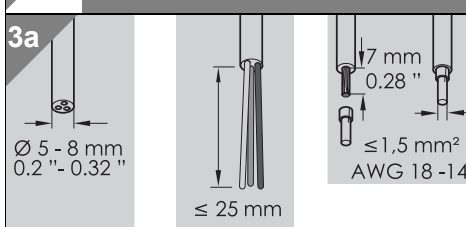

**4**  
4a - 480  
4b - 580

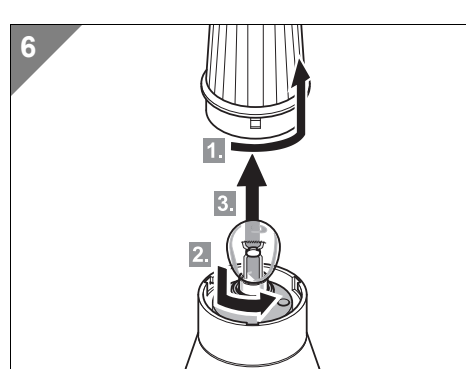
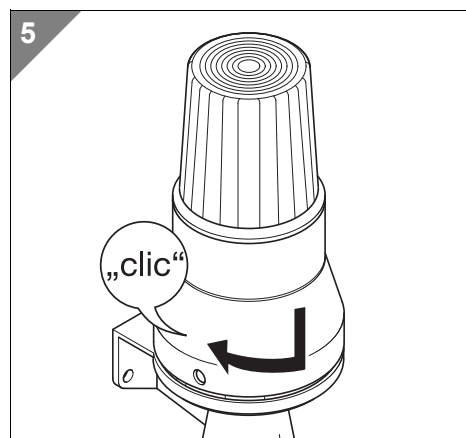
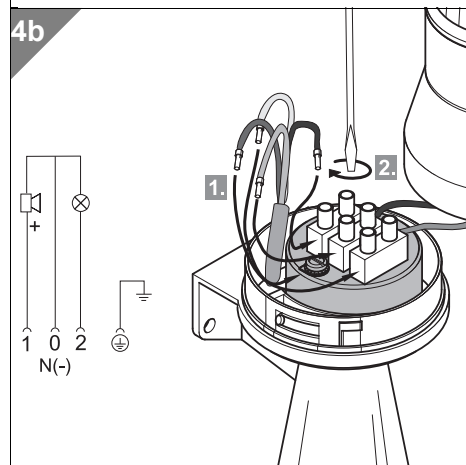
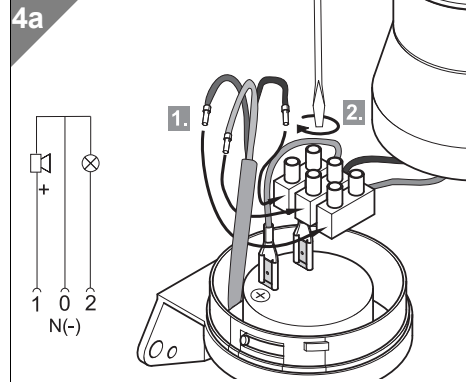

310.480.001.0212

© D

**WERMA**  
SIGNALTECHNIK